

Section II - LSS models

Inventory list.

Wing box

2	LSS-2W-100 L & R	Wing panels (Left and Right)
2	LSS-A-100 L & R	Aileron Assy's (Left and Right)
28	LSS-2RB1X	Wing ribs (Top) Clipped Wing only
(32	LSS-2RB1X	Wing ribs (Top) Long wing only)
2	LSS-2RB1X-A	Wing ribs (Top) - Longer by 3/8" for wing tip angle
14	LSS-2RB2X	Wing ribs (Bottom) (16 on Long wing LSS)
2	LSS-2RB2X-A	Wing ribs (Bottom) - Longer by 3/8" for wing tip angle
8	LSS-BRC2	Bottom rib channel (10 on Long Wing LSS)
2	LSS-W5X	Flat sheet Alum. 8" x 62" (top, inboard wing)
2	LSS-W5X-CH	Channel sheet, 6" x 59" with 1" 90 deg bends. Inboard.
4	LSS-LEW-CH	Leading edge wrap channel, 2 @ 61", 2 @ 73" Clipped wing only
6	LSS-LEW-CH	(Leading edge wrap channel, 4 @ 61", 2 @ 37" Long wing only)
2	LSS-2W-003	Leading edge spar extension. 6" x 1 7/8" x .049 6061-T6
2	LSS-2W-004	Trailing edge spar extension, 12" x 1 3/4" x .058 6061-T6
3	LSS-WTB	Wing tip brace L-bracket 3 @ 3/4" x 2" x 20" (customer to cut—for making 8 wing tip brace brackets)
2	LSS-WTBS	Wing tip brace sheet, 2 @ 4 1/2" x 24" (customer to cut—for making 4 wing tip braces)
2	LSS-RWTWS	Rear wing tip wrap sheet. .019 soft alum sheet.

Sect. II box

1	QT-PT	Poly-Tac adhesive, quart.
1	QT-MEK	Methyl Ethyl Keytone, quart.
4	ST-400X - 14" long	Wing fabric CW, 2 pkgs. (or Long Wing - 16" long)
2	LSS-ST-306	Aileron fabric, CW (or long wing) 22" x 8.5ft (22" x 9.5ft long wing)
1	LSS-WTT-2W5X	1 Piece 16" x 121" x .020 flat sheet roll. Customer to cut
	LSS-WTB-2W5X	(wing tip, top and bottom sheets)

Hardware bag

26	W1XX	Wing rib gussets (front of wing rib) - Clipped wing
26	W1X	Wing rib gussets (rear of wing rib) - Clipped wing
32	W1XX	Wing rib gussets (front of wing rib) - Long wing
32	W1X	Wing rib gussets (rear of wing rib) - Long wing
1	ST-ST	2" Seam tape
1	ST-RT	3/8" Reinforcing tape
8	A-007	Aileron hinge
8	WS1	Strut attach bracket
2	LSS-RWTFR	Rear wing tip filler rib
4	AN3-23A	Bolt 3/16", for rear strut attach bracket.
4	AN3-24A	Bolt 3/16", for front strut attach bracket
8	AN365-1032	Nyloc nuts, 3/16
500	SSD42SSBS	S.S. rivets 1/8" x 1/8" (short)
400	SSD44SSBS	S.S. rivets 1/8" x 1/4" (long)
250	AD42ABS	Alum. Rivets 1/8" x 1/8" (short)
400	AD42ABSLF	Alum. Rivets 1/8" large flange

Packed in separate box

2	WT-002	Fiberglass wing tips. (Left and right)
---	--------	--

LEFT LSS - Wing panel (bottom)

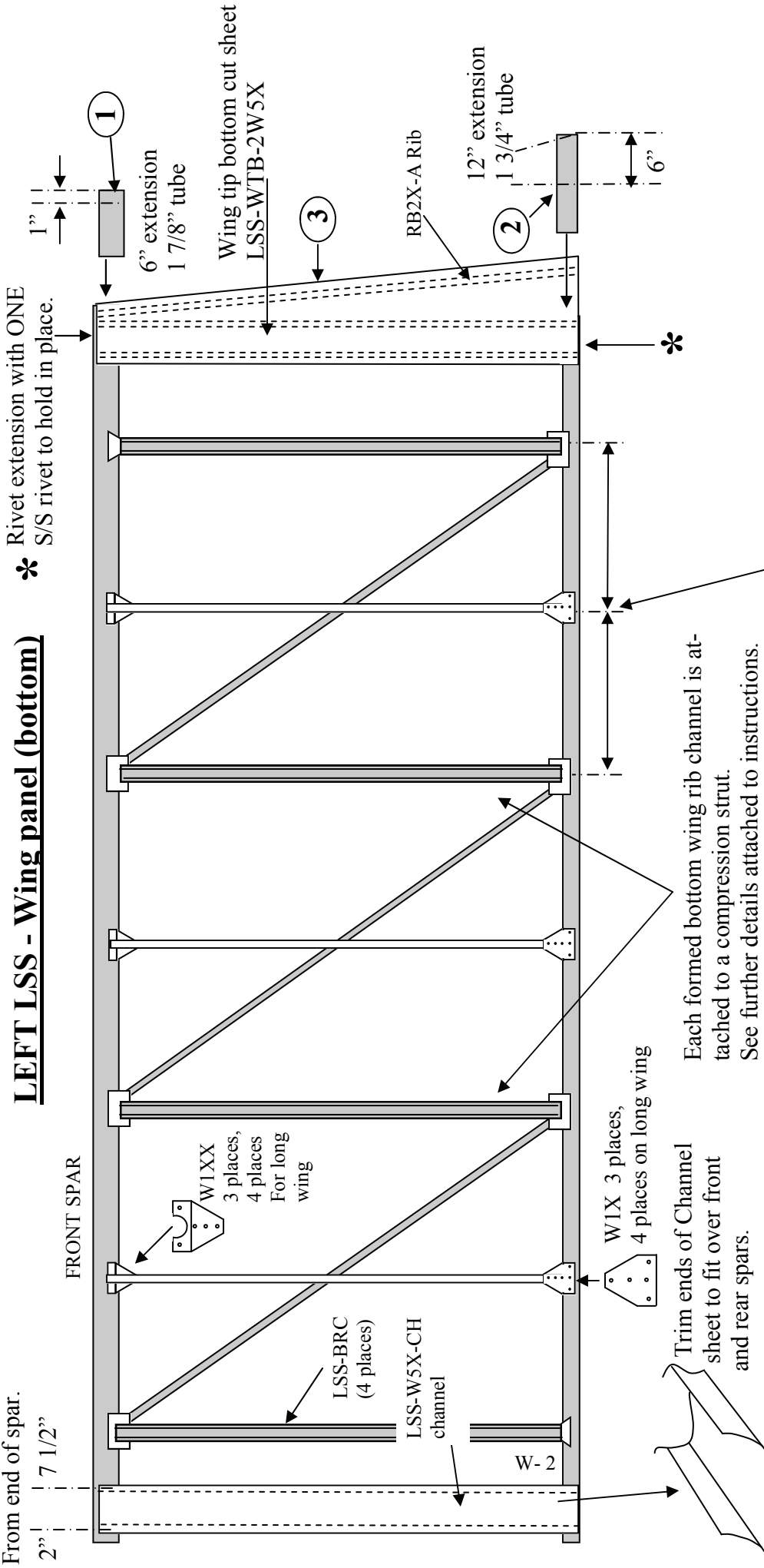

1. Insert extension tube on front wing spar until 1" is showing & rivet.
2. Insert extension tube on rear wing spar until 6" is showing.
3. Place the outer (angled) ribs so that there is approx 3/4" overlap of the flat sheets to attach fiberglass wing tip. The outer ribs (RB2X-A) are attached to the leading edge spar and the trailing edge extension. Do not install wing tips yet.

RIGHT LSS - Wing panel (top)

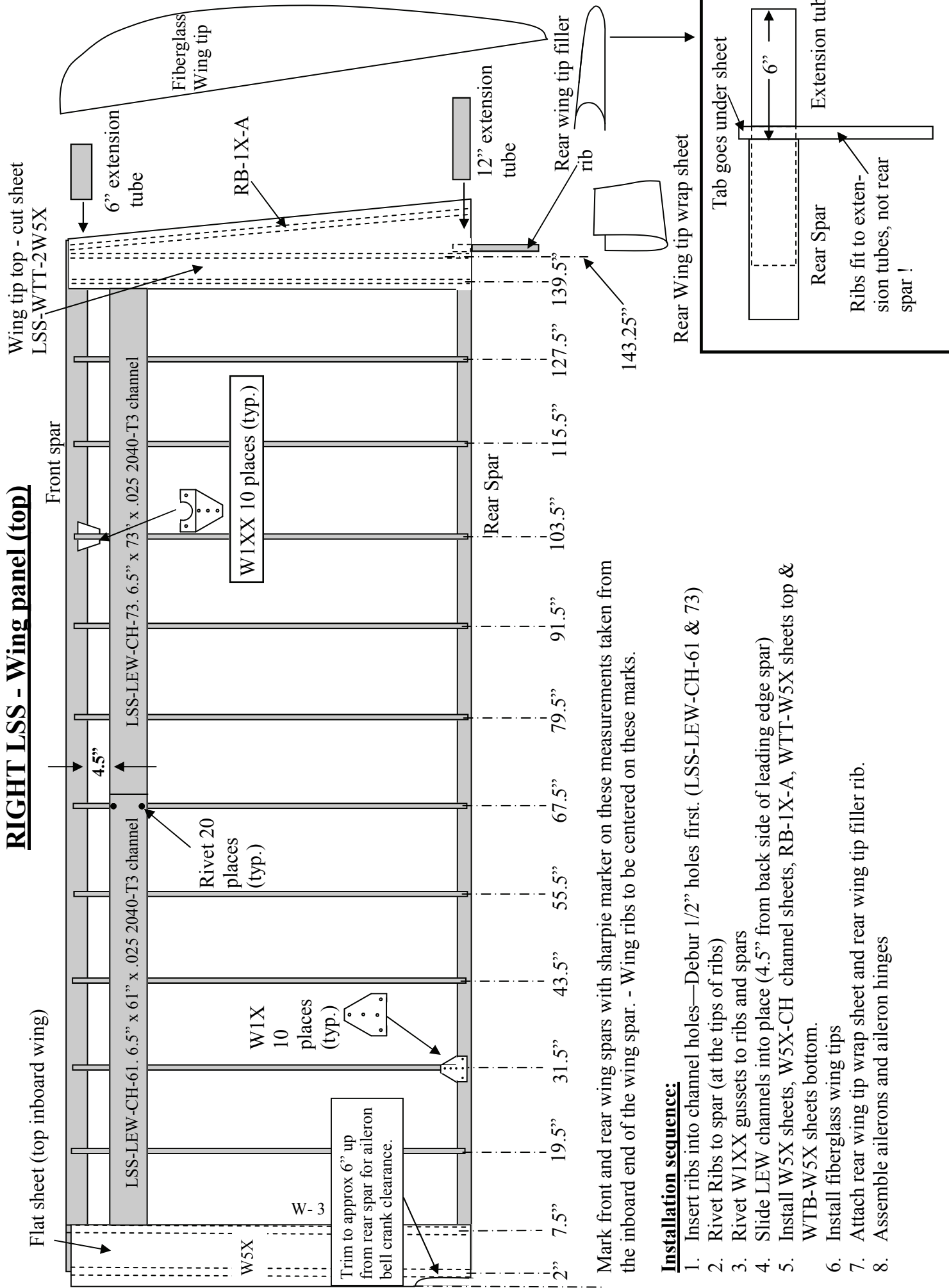

Mark front and rear wing spars with sharpie marker on these measurements taken from the inboard end of the wing spar. - Wing ribs to be centered on these marks.

Installation sequence:

1. Insert ribs into channel holes—Debur 1/2" holes first. (LSS-LEW-CH-61 & 73)
2. Rivet Ribs to spar (at the tips of ribs)
3. Rivet W1XX gussets to ribs and spars
4. Slide LEW channels into place (4.5" from back side of leading edge spar)
5. Install W5X sheets, W5X-CH channel sheets, RB-1X-A, WTT-W5X sheets top & WTB-W5X sheets bottom.
6. Install fiberglass wing tips
7. Attach rear wing tip wrap sheet and rear wing tip filler rib.
8. Assemble ailerons and aileron hinges

RIGHT LSS - LONG WING ONLY (top)

Wing tip top - cut sheet
LSS-WTT-2W5X

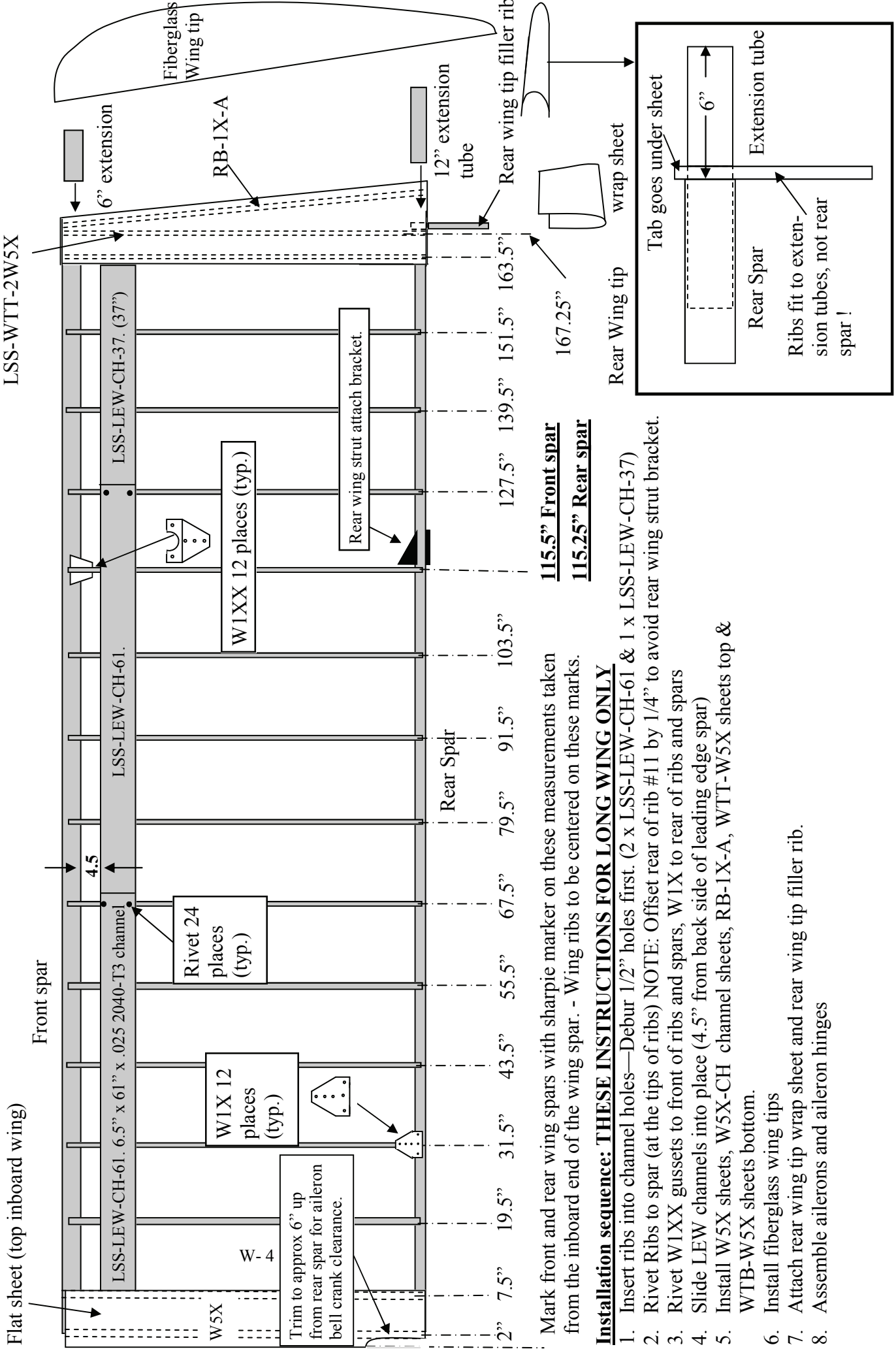

Mark front and rear wing spars with sharpie marker on these measurements taken from the inboard end of the wing spar. - Wing ribs to be centered on these marks.

115.5" Front spar

115.25" Rear spar

Installation sequence: THESE INSTRUCTIONS FOR LONG WING ONLY

1. Insert ribs into channel holes—Debur 1/2" holes first. (2 x LSS-LEW-CH-61 & 1 x LSS-LEW-CH-37)
2. Rivet Ribs to spar (at the tips of ribs) NOTE: Offset rear of rib #11 by 1/4" to avoid rear wing strut bracket.
3. Rivet W1XX gussets to front of ribs and spars, W1X to rear of ribs and spars
4. Slide LEW channels into place (4.5" from back side of leading edge spar)
5. Install W5X sheets, W5X-CH channel sheets, RB-1X-A, WTT-W5X sheets top & WTB-W5X sheets bottom.
6. Install fiberglass wing tips
7. Attach rear wing tip wrap sheet and rear wing tip filler rib.
8. Assemble ailerons and aileron hinges

How to connect the LSS LEW Channel sheets

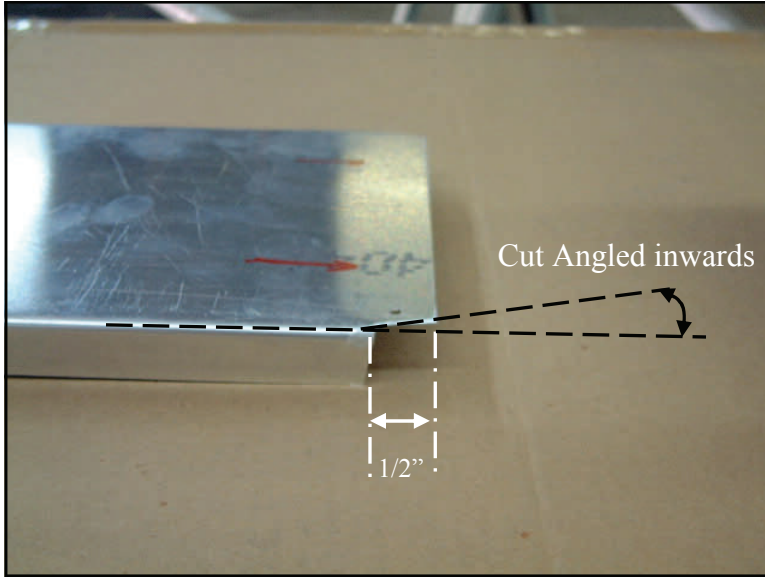

Trim the end of the LSS LEW Channel sheet as shown. Only ONE end requires trimming

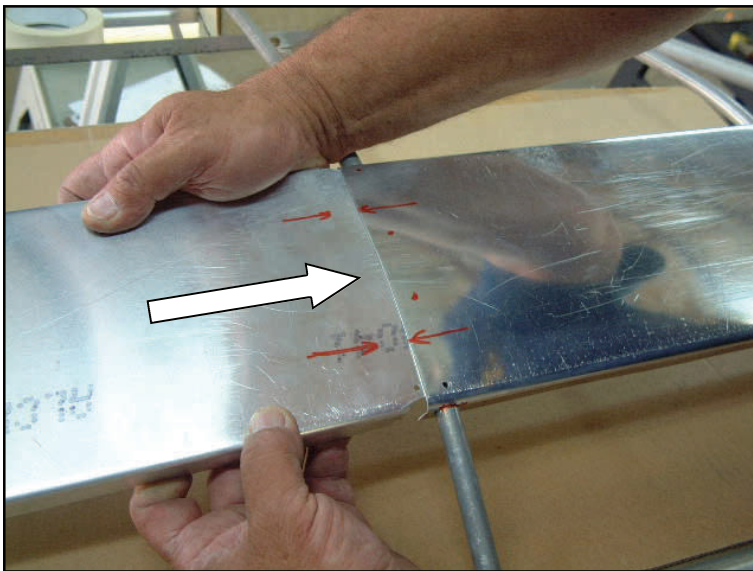

Slide the trimmed end UNDER the previously installed LSS LEW Channel sheet

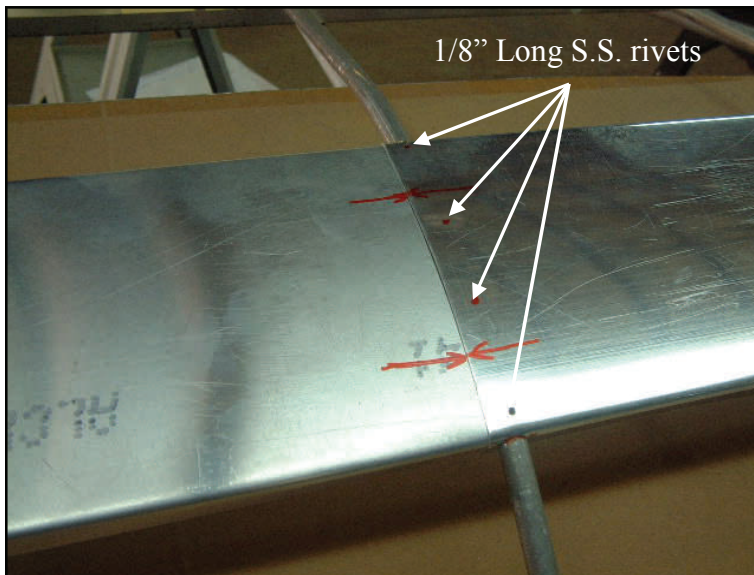

Once the joint is square and all looks good, rivet the two LSS LEW Channel sheets together onto the rib.

Detail Drawing W-A

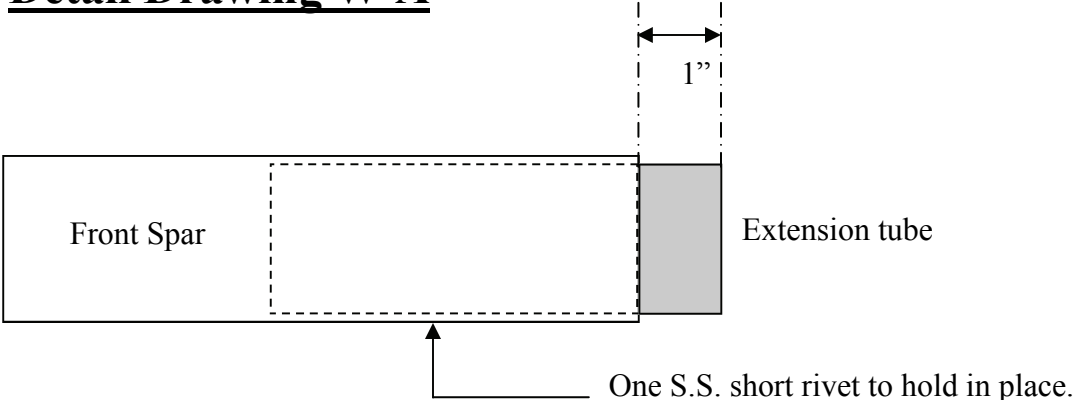

Detail Drawing W-B

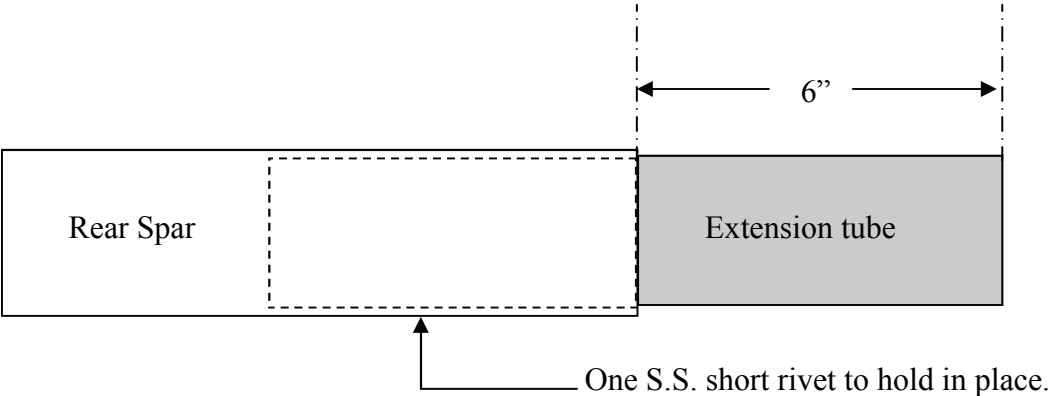

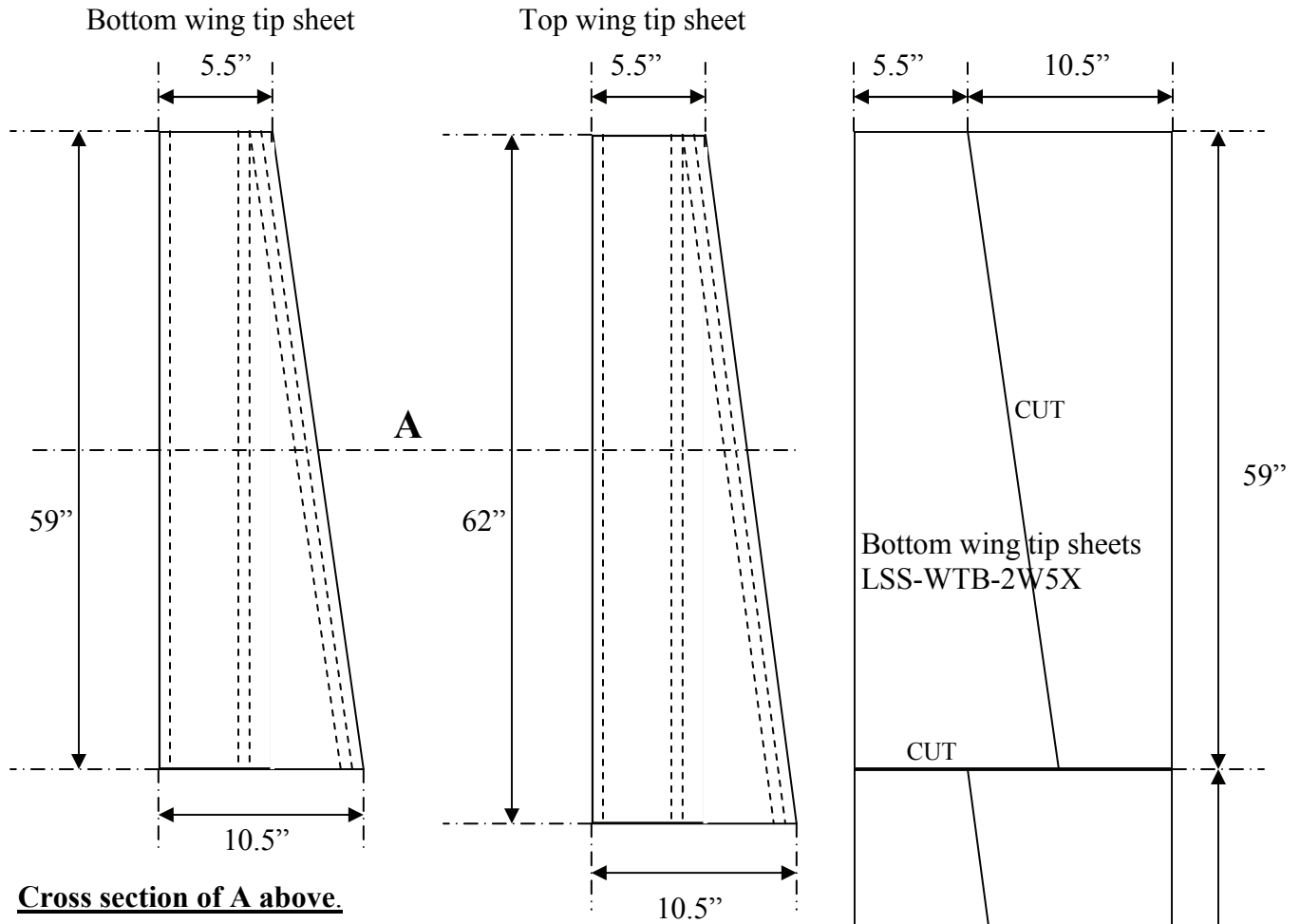

Cross section of A above.

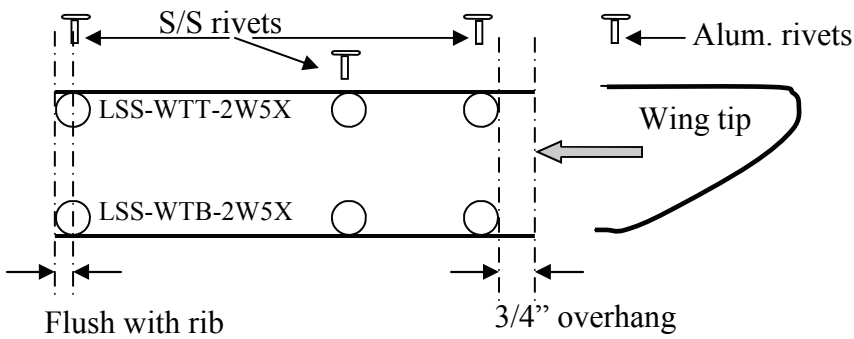

All rivets are 1/8" short except through wing spars.
Rivets through wing spars are 1/8" long

Space all rivets approx 4" apart except on spars, these should be approx 3/4" apart.

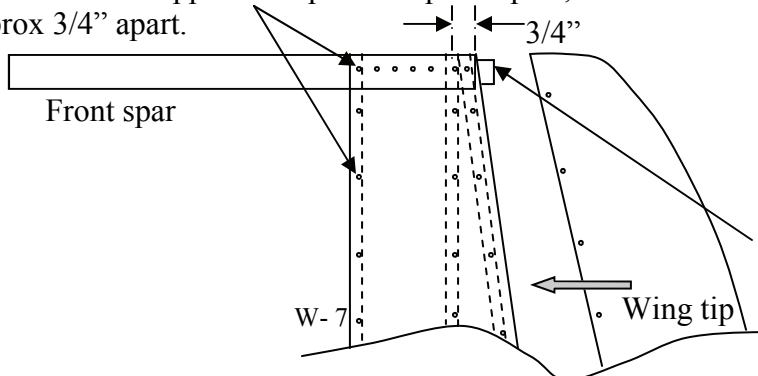

Use two 3/16" long Alum. Rivets to secure Wing tip to 6" extension. Repeat for rear extension.

This sheet is 121" long and requires cutting to shape.

Formed bottom wing rib (LSS-BRC)

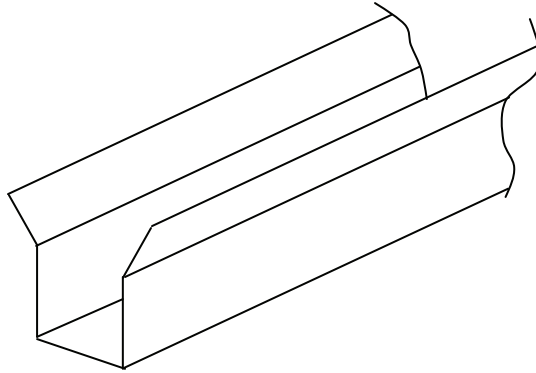

This formed bottom rib channel is to be installed over the wing compression tubes (4 per wing panel) to hold the bottom fabric from pushing up against the compression and drag/anti-drag tubes.

Regular round tubing ribs (3 per wing panel) will be installed half way between each wing compression tube with the same gussets used on the top wing ribs.

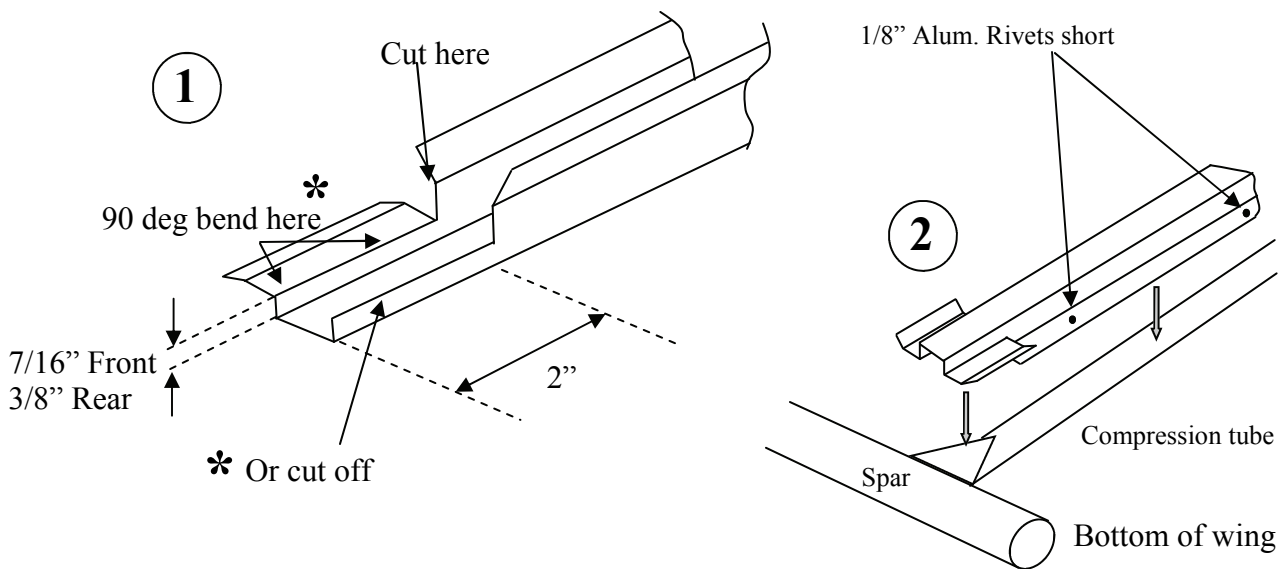

3 Use a straight edge to level the bottom wing rib channel before riveting in place.

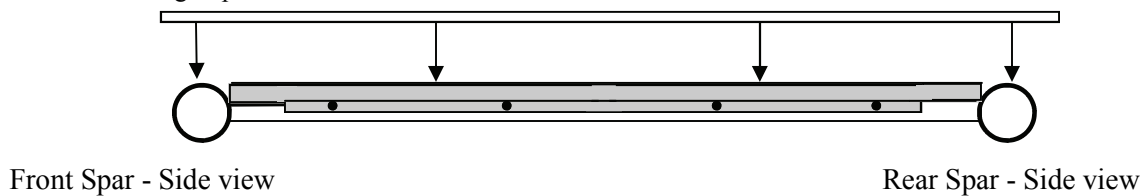

How to install Aileron hinges - Hinge location

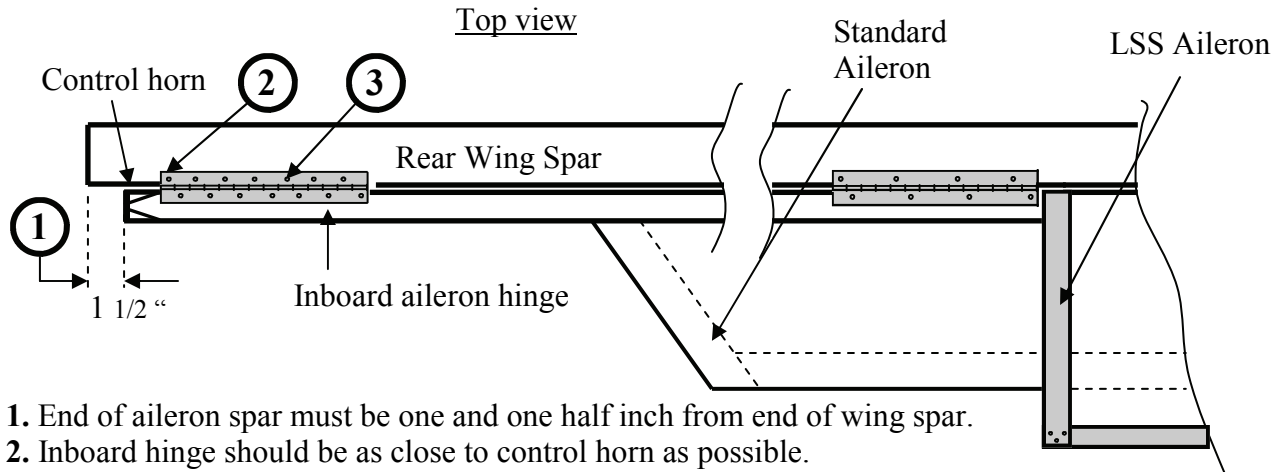

1. End of aileron spar must be one and one half inch from end of wing spar.
2. Inboard hinge should be as close to control horn as possible.
3. Stagger rivets to allow more aileron travel.

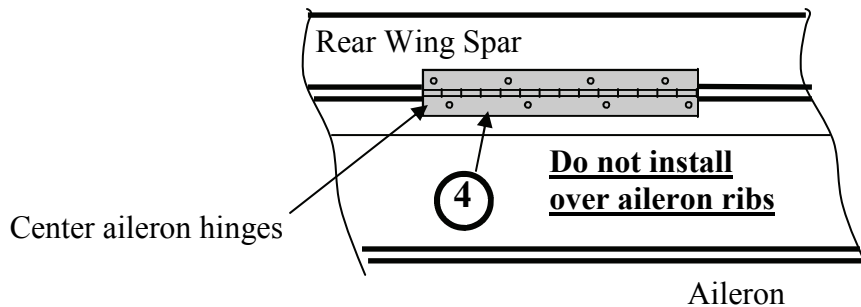

4. Four rivets per side on all hinges except inboard hinge; which gets eight per side. The two center hinges must be spaced evenly between inboard and outboard hinges without interfering with ribs or wing strut brackets.
5. Outboard hinge should be 2" from end of aileron.

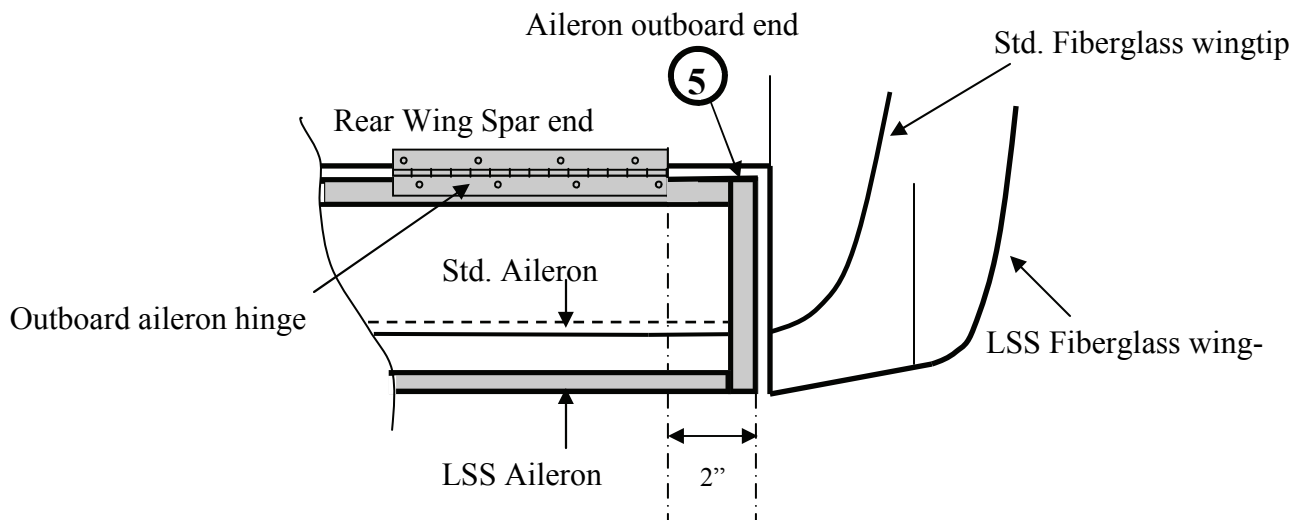

How to install Aileron hinges - Hinge location

Side view

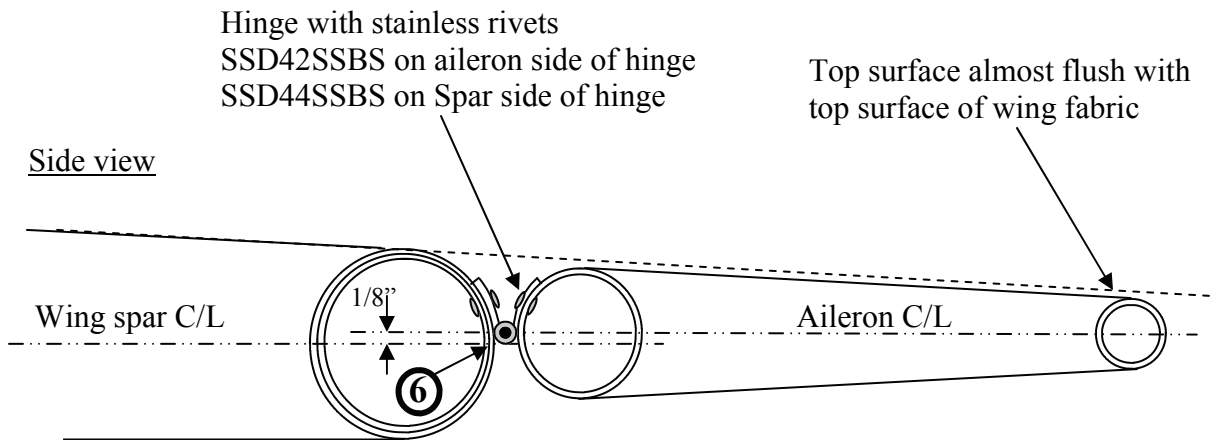

Try for 30 deg up and down aileron deflection

6. Center of hinge should be on the center line of aileron. Bottom of hinge barrel should be on centerline of rear spar.

LSS - Long wing aileron installation

Refer to previous pages for the correct hinge assembly procedure.

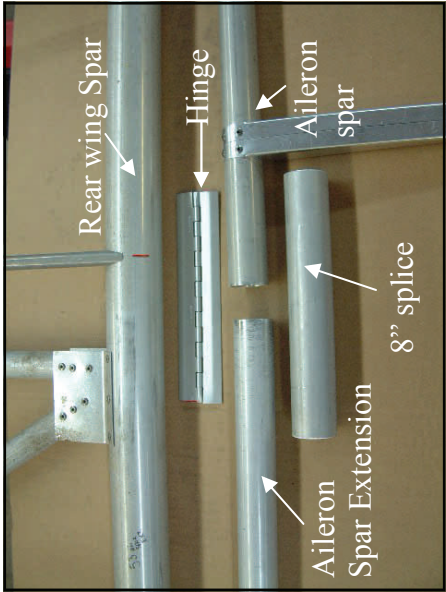
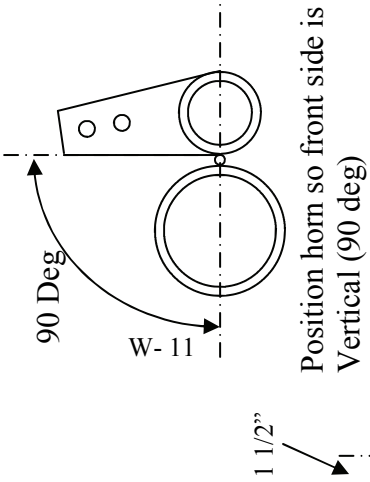

Space the hinges as shown, every 3rd aileron bay.

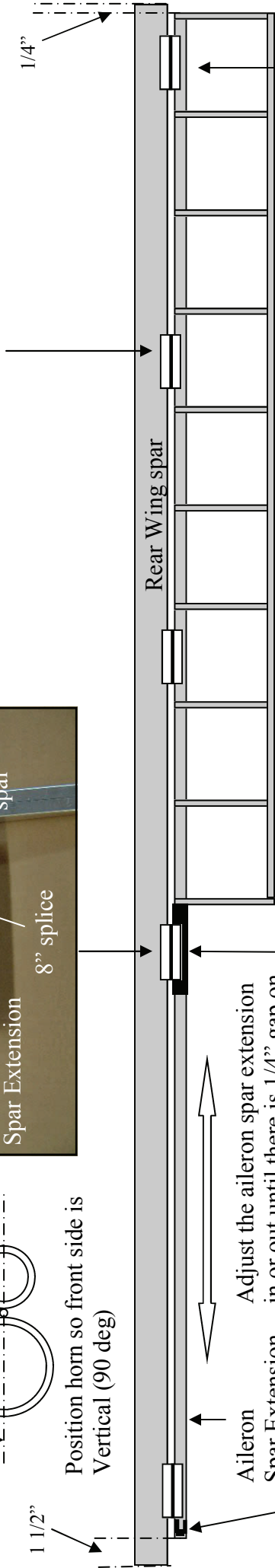

Adjust the aileron spar extension in or out until there is 1/4" gap on outboard end and 1 1/2" gap at aileron horn end. Front side of Aileron horn must be 90 deg to horizontal. See small drawing. Rivet the splice in place. Attach hinges as previously described.

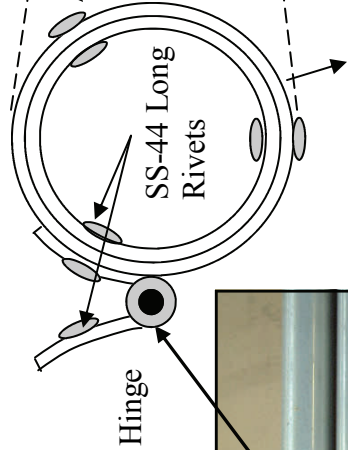

Secure splice in place with two rows of 1/8" Stainless steel rivets each end. Attach the hinge as previously described but with long SS

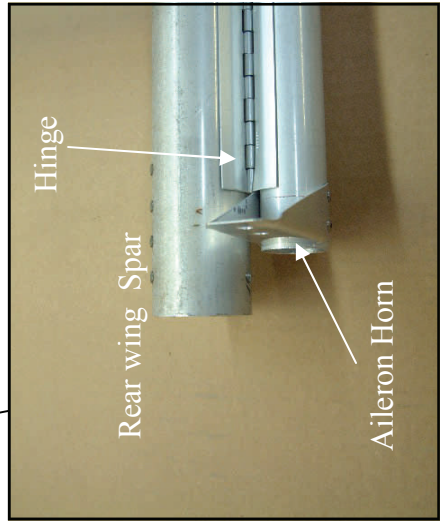
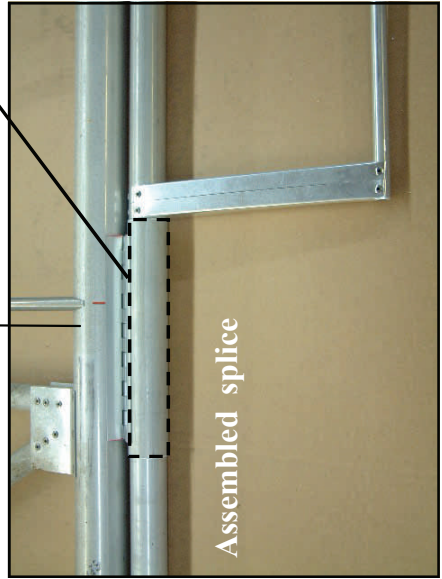



Rivet ribs to spar at marks. Make sure you slide the ribs through the wrap channel first !!



Overlap the leading edge wrap channels at a rib. Some trimming will be required.

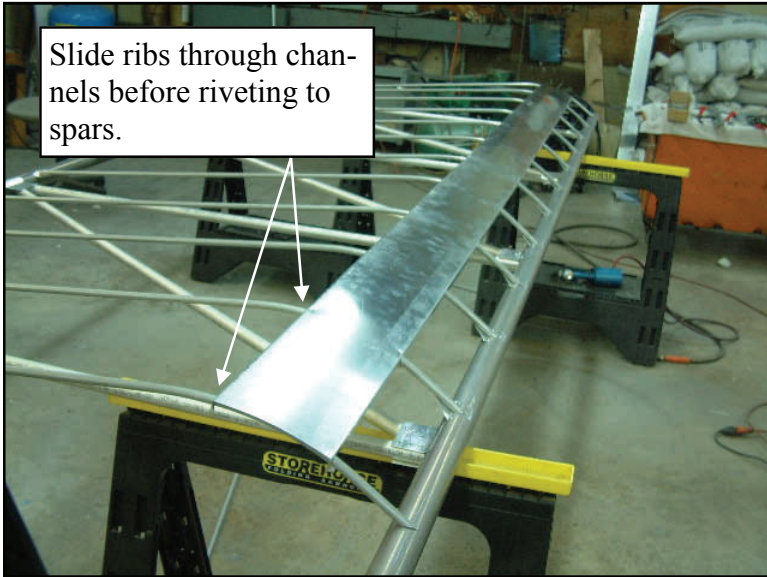

Slide ribs through channels before riveting to spars.

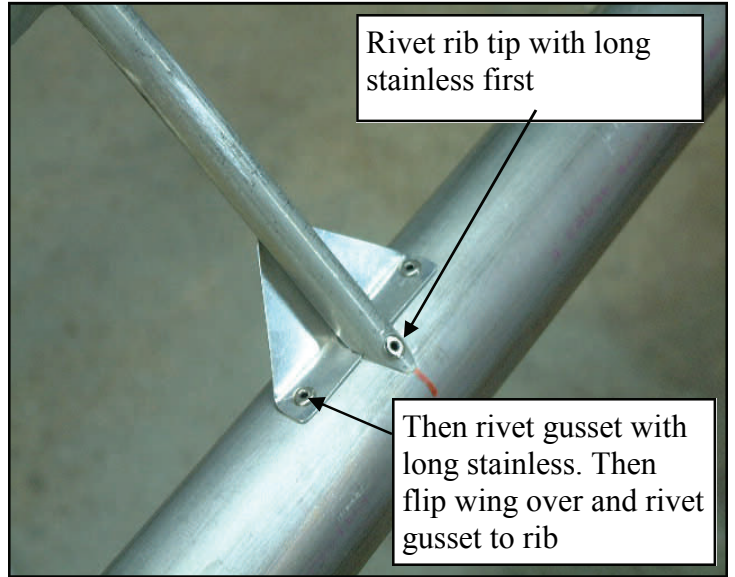

Rivet rib tip with long stainless first

Then rivet gusset with long stainless. Then flip wing over and rivet gusset to rib

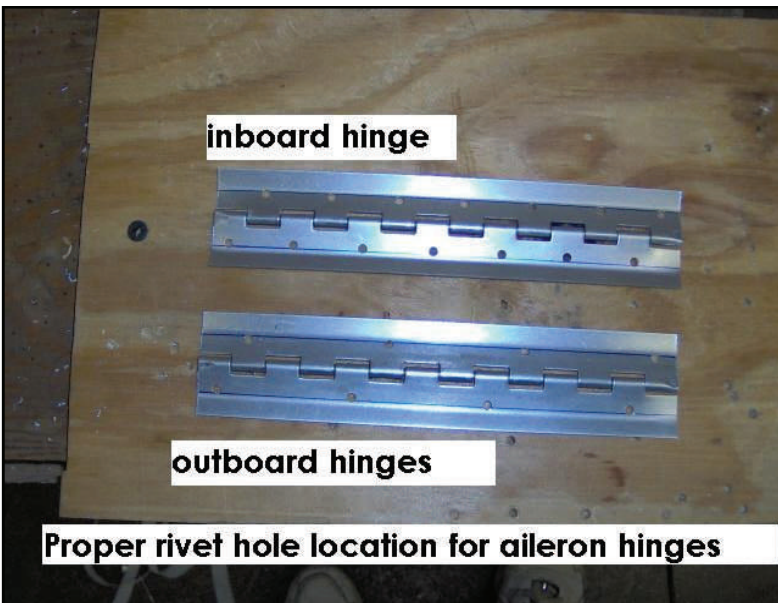

inboard hinge

outboard hinges

Proper rivet hole location for aileron hinges

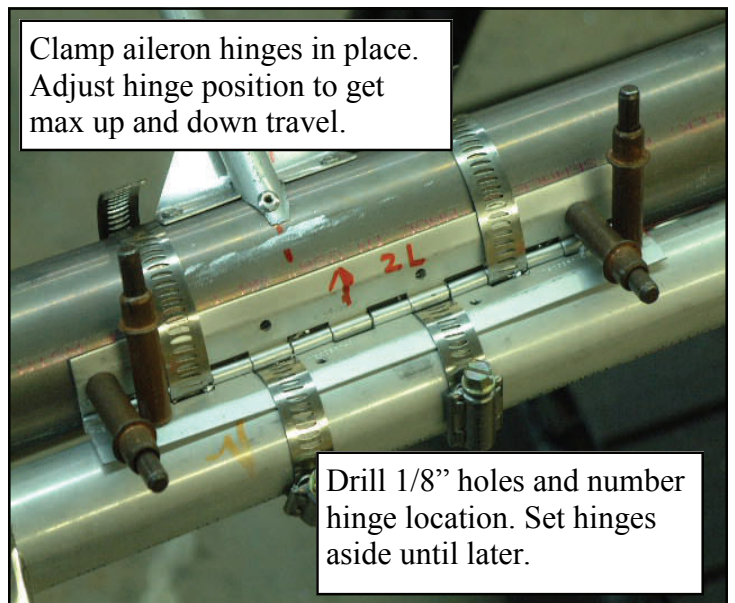

Clamp aileron hinges in place. Adjust hinge position to get max up and down travel.

Drill 1/8" holes and number hinge location. Set hinges aside until later.

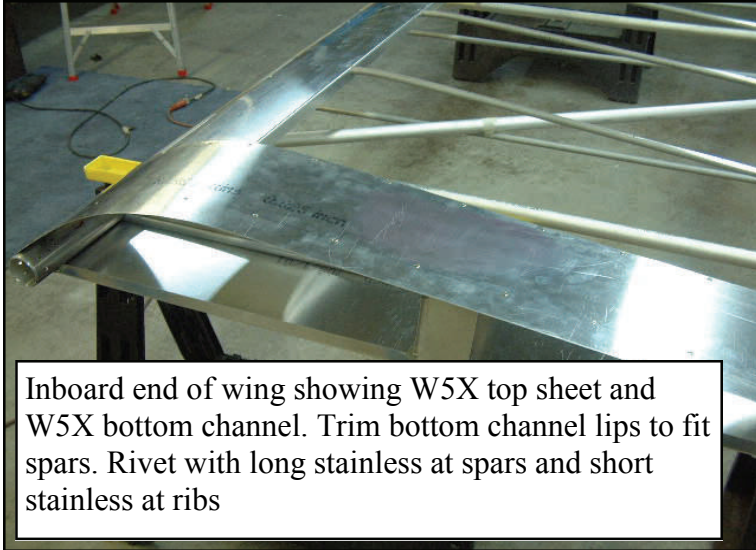

Inboard end of wing showing W5X top sheet and W5X bottom channel. Trim bottom channel lips to fit spars. Rivet with long stainless at spars and short stainless at ribs

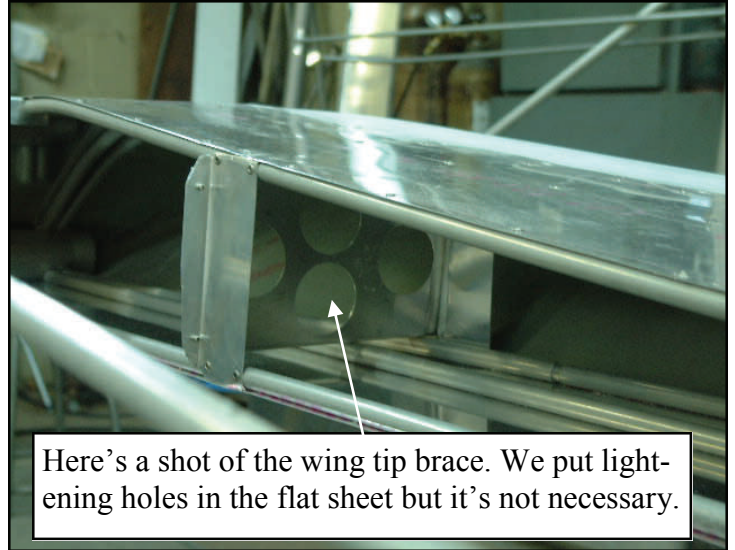

Here's a shot of the wing tip brace. We put lightning holes in the flat sheet but it's not necessary.



Clecos and clamps make things easier. Inboard top W5X sheet being installed.

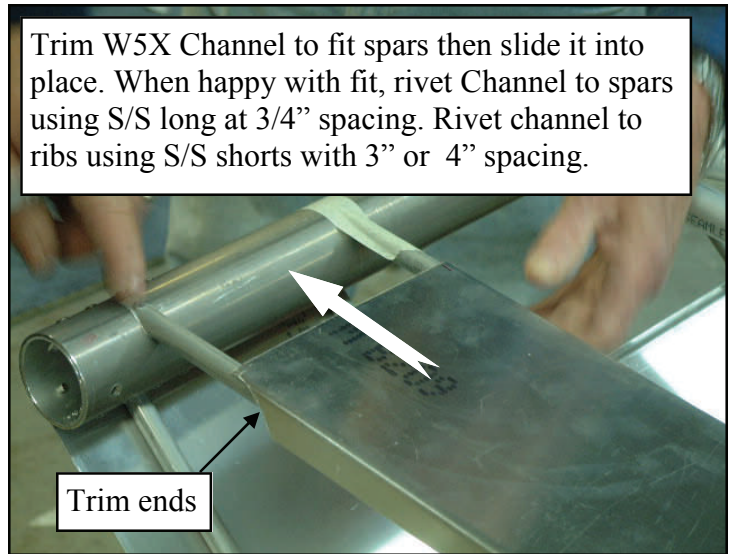

Trim W5X Channel to fit spars then slide it into place. When happy with fit, rivet Channel to spars using S/S long at 3/4" spacing. Rivet channel to ribs using S/S shorts with 3" or 4" spacing.

Trim ends

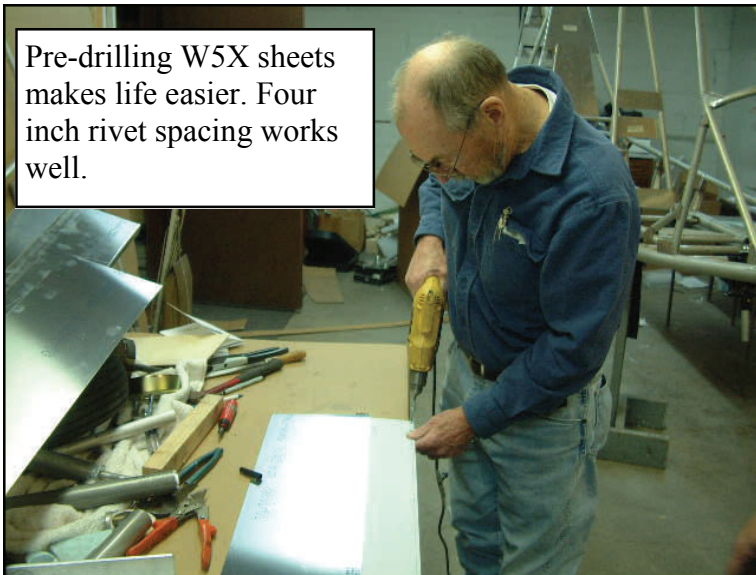

Pre-drilling W5X sheets makes life easier. Four inch rivet spacing works well.

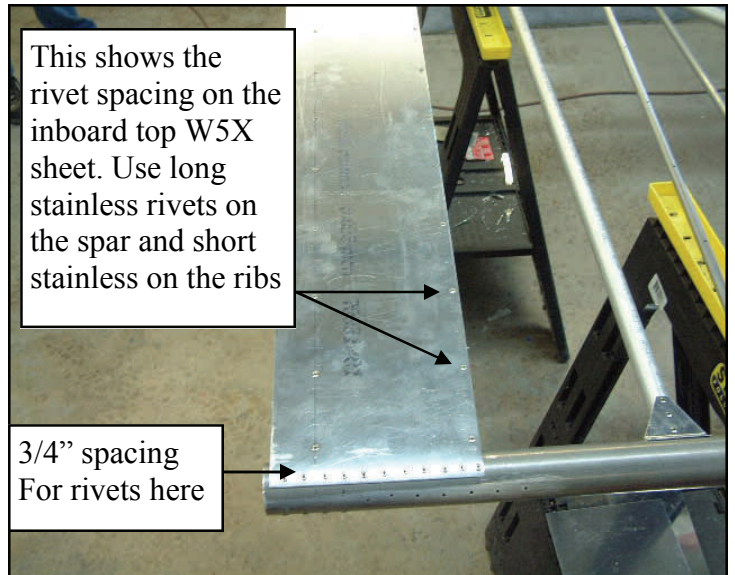

This shows the rivet spacing on the inboard top W5X sheet. Use long stainless rivets on the spar and short stainless on the ribs

3/4" spacing For rivets here

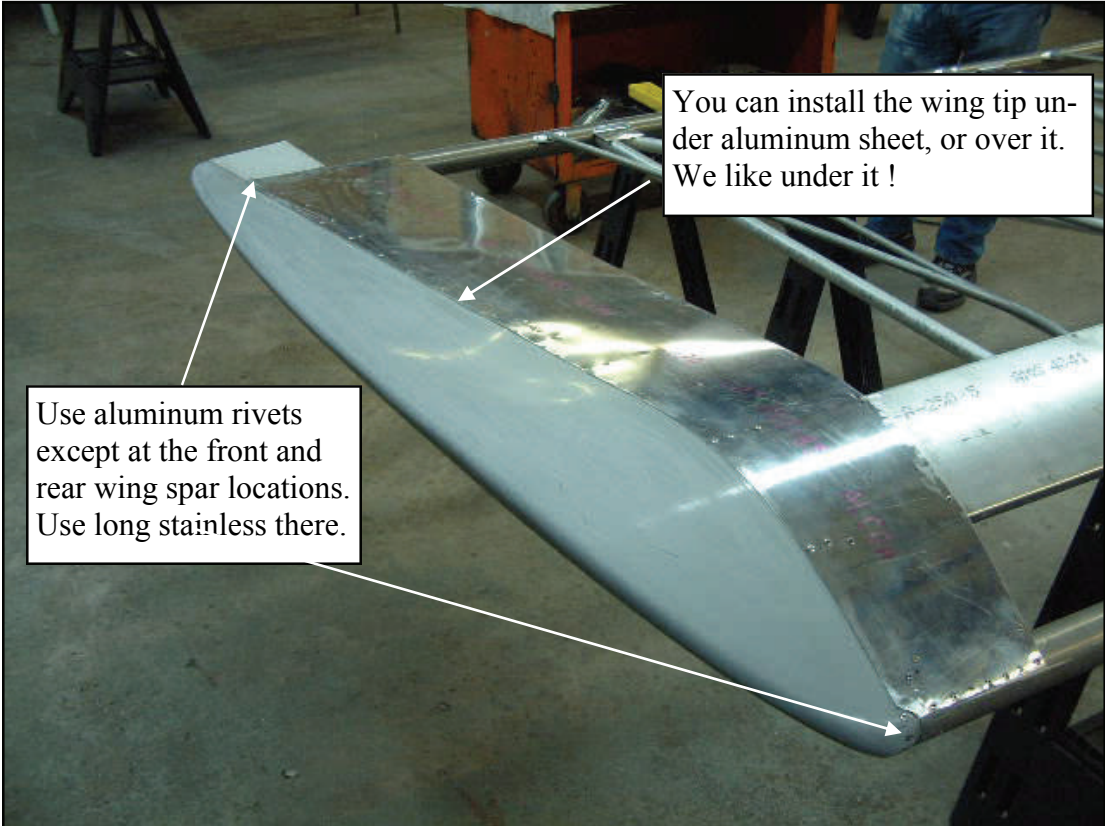
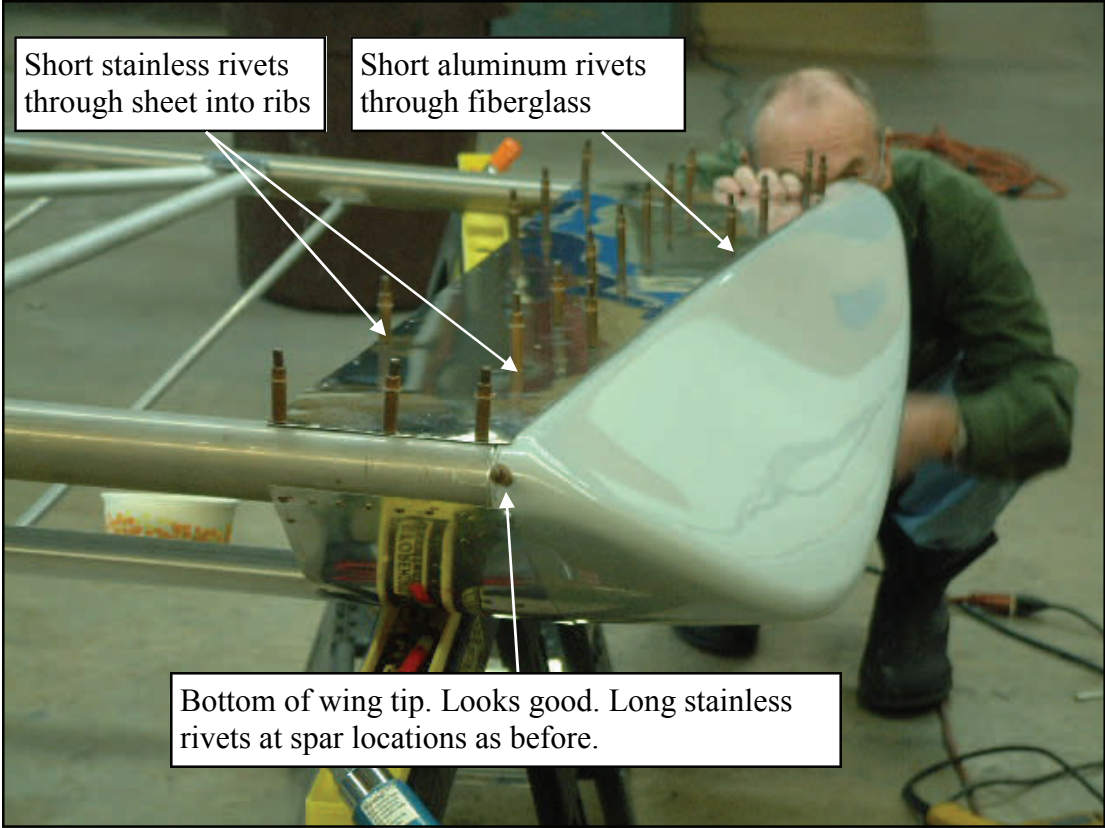



If you did everything right, your wingtips should look like this.



And after painting, they should look like this.

w

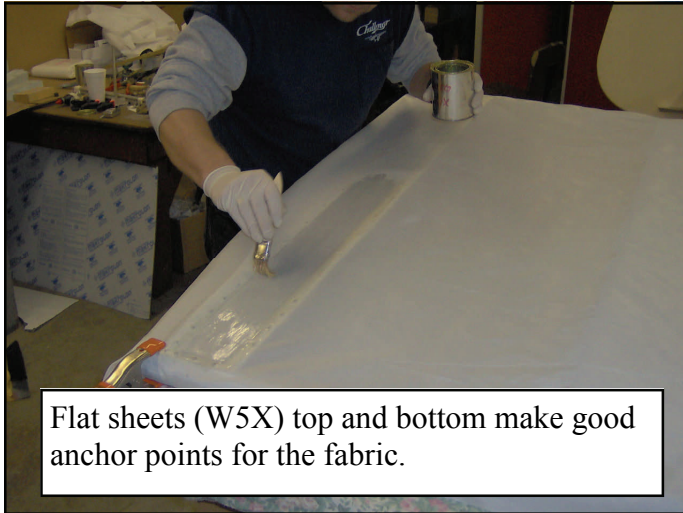

Flat sheets (W5X) top and bottom make good anchor points for the fabric.

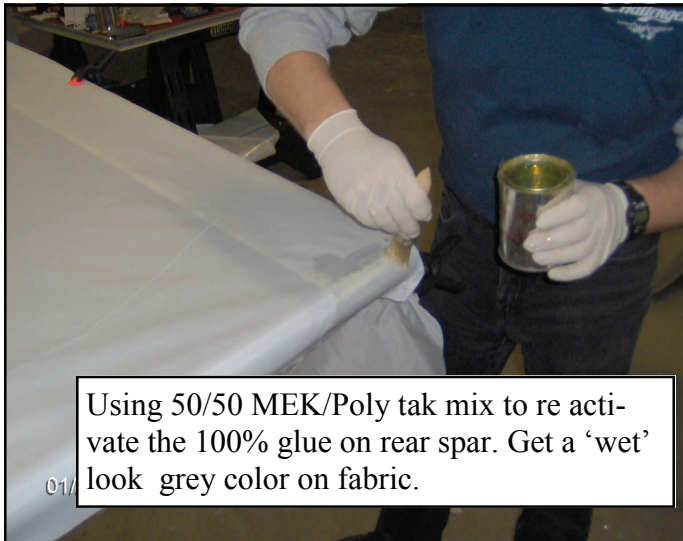

Using 50/50 MEK/Poly tak mix to re activate the 100% glue on rear spar. Get a 'wet' look grey color on fabric.

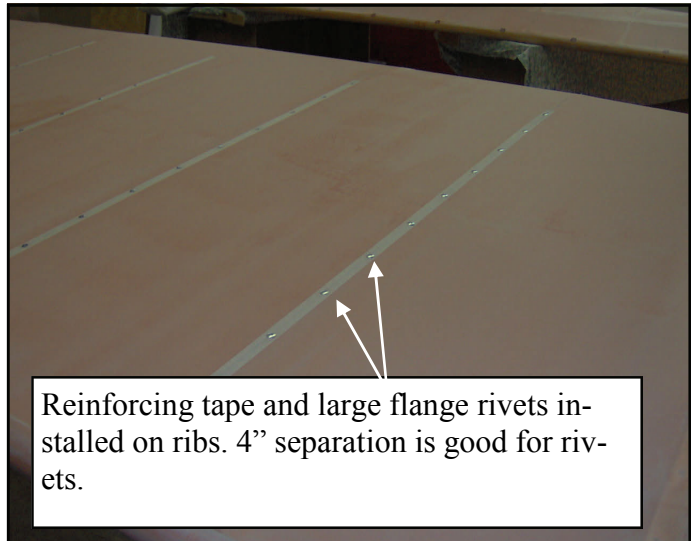

Reinforcing tape and large flange rivets installed on ribs. 4" separation is good for rivets.

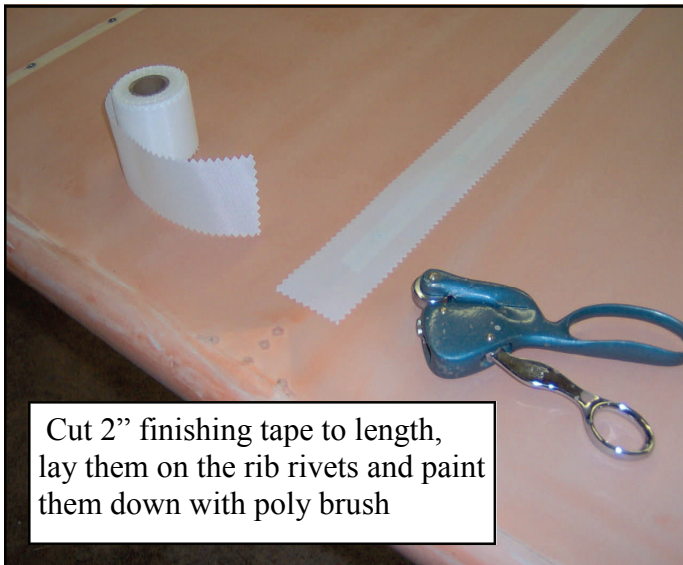

Cut 2" finishing tape to length, lay them on the rib rivets and paint them down with poly brush

When you have covered the wings and ailerons and have applied fabric sealant (Poly-Brush), locate the previously drilled hinge locations and install the aileron hinges.

Important : Make sure you have the correct hinge for each attachment point. It will be highly unlikely that a different hinge will fit the holes you have previously drilled



Inboard hinge needs lots of stainless rivets. Longs on the spar and shorts on the aileron. Looks good. Lets get going

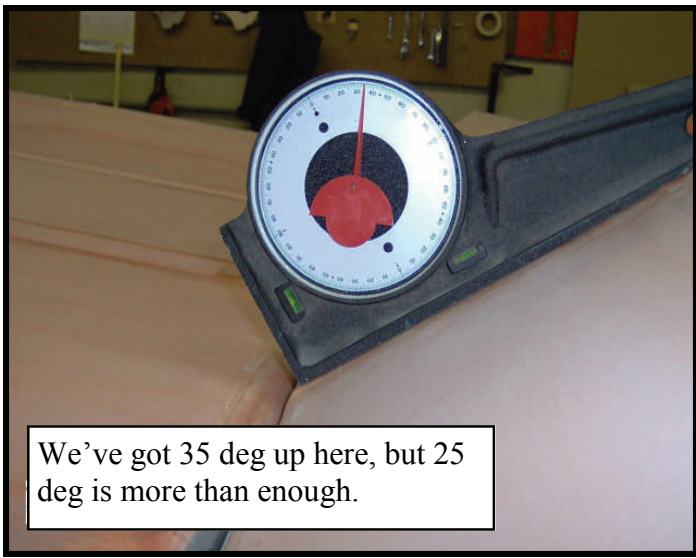

We've got 35 deg up here, but 25 deg is more than enough.



Outboard hinge installation

Typical outboard hinge installation. Note: Holes are drilled at every OTHER hinge barrel. 4 each side for outboard hinges. Inboard hinges are drilled at every hinge barrel point (7 each side).

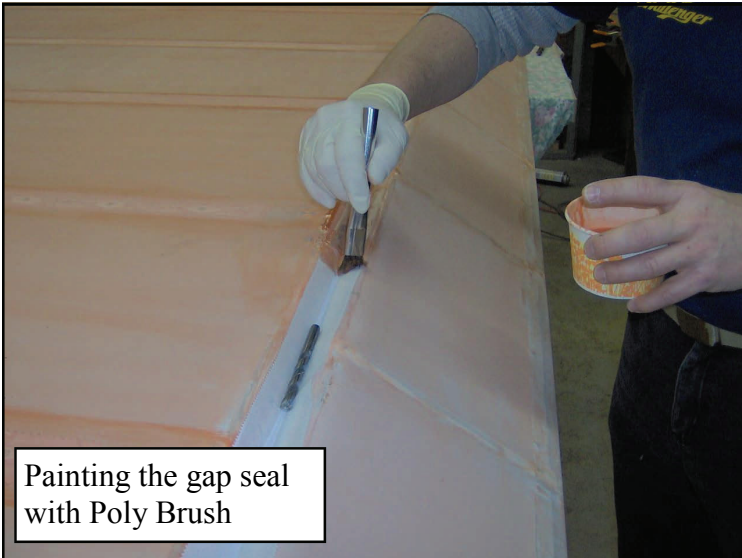

Painting the gap seal with Poly Brush

This is the way to create a gap seal. Lay 2" finishing tape in the space between aileron and wing. Aileron must be in the down position. Lay some drill bits in the groove to keep the tape in place and simply apply Poly-Brush.

Pictures of painted wing

