

Challenger II - LSS

Section III **Fuselage**

Challenger II - LSS Inventory

A: Parts on or in Fuselage:

()	4 STB-100	(Stabilizer struts with hardware attached)	See A-1
()	2 2S-001	(Front wing struts with hardware attached)	See A-2
()	1 2S-002-R	(right rear wing strut with hardware attached)	See A-2
()	1 2S-002-L	(Left rear wing strut with hardware attached)	See A-2
()	1 DF-100	(Dorsal Fin with hardware attached)	See A-3
()	1 NG-100	(Nose gear assembly with hardware attached)	See A-4
()	1 JS-200	(Set of jury struts, 4pcs. @ 24" & 4pcs. @ 48")	

A-1

4	UB-1S	Stainless steel U-brkt.
4	UB-3S	Stainless steel U-brkt.
8	AN525-10R14	Screw bolt
8	AN365-1032	Nyloc nut

A-2

4	AN4-24A	bolt
4	AN365-428	Nyloc nut
8	S-84	Black nylon saddle
4	EC-7	End cap, 1 5/8"

A-3

4	UB-2S	Stainless U-brkt.
4	AN525-10R14	Screw bolt
4	AN365-1032	Nyloc nut

A-4

2	1/4" x 28 S.S.	Threaded rod
4	NF-4	Ball Joint
4	AN316-4	Jam nut
4	AN4-7	Bolt
8	AN960-416	Washer
4	AN365-428	Nyloc nut
2	HC-34	3/4" S.S. hose clamp
2	HC-114	1 1/4" S.S. hose clamp
4	FW-25	1/4" hardware washer

B: Section III hardware box:

()	2	SC-A Seat cushion assembly, front and rear
()	2	FG-99 Rear boom brace gusset (.025—2024-T6)
()	1	EL-100 Elevator push rod tube set, 6 pcs. 4 @ 16" .50 x .035 2 @ 12" .625 x .058 w/hdwr. 4 AN490-HT8P threaded rod end, 4 NF-4 ball joint, 4 AN316-4 jam nut, 4 AN4-7A bolt, 8 AN365-428 Nyloc nut, 8 AN960-416 Washer, 4 1/4" hardware washer.
()	1	PL-100 Pedal interconnect tube set, rudder. 6 pcs. 4 @ 13 3/4" (.50 x .035), 2 @ 12" (.625 x .058) 4 AN3-5 bolt, 4 AN310-3 castle nut 3/16, 4 AN380-2-4 cotter pin

Challenger II - LSS inventory continued:

B: Section III hardware box: (cont.)

- () 1 AL-100 aileron pushrod set, 2 pcs. With hardware
 - 2 .50 x .035 tubing 11"
 - 2 AN49-HT8P threaded rod end,
 - 2 NF-4 ball joint, 2 AN316-4 jam nut, 2 AN4-7A bolt
 - 2 AN365-428 nyloc nut, 2 AN960-416 washer
 - 2 3246 clevis fork, 2 hdwr washer
 - 2 AN3-5 bolt 3/16, 2 AN310-3 castle nut, 2 AN380-2-4
Cotter pin.

- () 1 JS-200X jury strut hardware bag
 - 12 ST-16L S.S. bracket
 - 4 ST-16A Angled L bracket, 2 left, 2 right
 - 16 ST-16F S.S. flat bracket
 - 12 AN525-10R14 screw bolt
 - 2 AN525-10R16 screw bolt
 - 14 AN365-1032 nyloc nut
 - 50 AD64ABS 3/16" alum. Rivet long, L-brkt to spar & struts
 - 50 AD62ABS 3/16" alum. Rivet short, ST-16F to jury strut

- () 1 LSS-LG-100 Nose gear for assembly 6" with axle, 2- 3/4" x .049 x
2 1/4" alum. Spacer, 1 - 8" grade 8 bolt & 3/8" nyloc nut,
1 AN3-14A bolt, 1 AN365-1032 nyloc nut, 1 AN960-10 washer
3/16", 2 - 5/16" hardware washers.

- () 2 LSS-LG-1 main gear legs, solid spring alum.
- () 4 AN4-17A bolt, for gear legs
- () 4 AN365-428 nyloc nut
- () 8 AN960-416 Washer, 1/4"
- () 1 LG-8 tail wheel assembly
- () 1 ST-200 Fuselage covering material - 4 pcs, pre-cut
- () 2 DEC-S Challenger decals, small
- () 1 FTH-2L throttle interconnect, w/handle
- () 2 LSS-EFF Engine front former
- () 2 LSS-FCF Front cockpit former
- () 1 LSS-DFVFG Dorsal fin to vertical fin gusset with 6 AD42ABS 1/8"
Short alum. Rivets and instructions.

Challenger II - LSS inventory continued:

C: Misc. Hardware bag:

- () 1 TT-100 Trim tab set w/hdwr. 6 ST-16L, 6 AN525-10R10 screw bolts
6 AN365-1032 Nyloc nuts, 12 AN960-10 Washer, 18 AD64ABS
Alum. Rivet 3/16" long.
- () 1 SM-SP mini spares hardware bag
- () 2 Grip - Control stick grips with caps
- () 6 AD64ABS Alum. Rivet long, 3/16
- () 25 AD42 Alum. Rivet short, 1/8"
- () 100 SSD42SSBS S.S. rivet short. 1/8"
- () 8' S-WIRE safety wire (for turnbuckles and prop bolts)

D: Spar and strut bracket bag.

- () 4 Rony-2 - 2" rony brkt. Black alum. U-brkt., for wing spars
- () 4 Rony-158 - 1 5/8" rony brkt. Black alum. U-brkt. For lift struts
- () 2 AN4-26A bolt for 2" rony - through root tube.
- () 4 AN4-26 bolt for attaching spars to 2" rony brkts
- () 4 AN4-24A bolt for attaching to 1 5/8" rony brkts
- () 4 AN4-22 bolt for attaching lift struts to 1 5/8" rony brkts
- () 8 AN310-4 castle nut 1/4"
- () 6 AN365-428 nyloc nut 1/4"
- () 6 AN960-416 washer 1/4"
- () 10 AN380-2-4 cotter pin

E: Throttle bag:

- () 1 QCU-336 throttle cable assembly with 3 way splitter and handle for 503
Or 582 with hdwr. & instructions
- () 8 AN742-D3 3/16" adel clamps for attaching throttle cable to fuselage
- () 12 AD64ABS 3/16" alum. Rivets long, for adel clamps (3 used for throttle
Stop bracket)
- () 1 ST-16L-TH throttle stop bracket

F: Fuel system hardware bag:

- () 13' FUEL-L Blue fuel line, 1/4" I.D.
- () 1 FILTER, fuel filter
- () 1 5381—X-type bungee cord
- () 14 HC-FL S.S. hose clamp (fuel line)
- () 4 3360S 3/8" nylon fuel line clamp
- () 4 AD64ABS alum. Rivet 3/16" long
- () 1 PRIMER, fuel primer bulb
- () 1 LSS-120S fuel shut off valve.

Challenger II - LSS inventory continued:

G: Fuel tank box:

()	1	TANK-10, 10 gallon tank with pick-up tube
()	1	TM-2-10, 10 gallon tank mount tube
()	1	TT-2-10, 10 gallon fuel tank tray set, 3 pcs
()	1	TANK-17, 17 gallon alum. Tank complete with hdwr
()	50	AD42ABS Alum. Rivet 1/8" short
()	16	SSD44SSBS S.S. rivet 1/8" long

H: Shoulder harness:

()	2	SH-1, shoulder harness
()	2	AN5-25A bolt
()	2	AN365-524 nyloc nut
()	2	AN970-5, large area washer
()	1	NPN—instruction sheet

I: Jury strut & Horizontal stabilizer strut fairings:

()	6	JSF-001 Jury strut and horizontal strut fairings, 5' pcs.
()	24	AD42ABS alum. Rivets, 1/8" short

J: Instrument package:

()	1	QCU-ASI, airspeed indicator
()	1	QCU-PITOT, Pitot kit
()	1	SSMK-3 Marking kit
()	1	QCU-ALT, Altimeter
()	1	TACH-6, tachometer
()	1	LSS-COMP, Compass
()	1	QCU-CHT-D, Dual cylinder head temp with 2 probes
()	1	QCU-EGT-D, Dual exhaust gas temp with 2 probes
()	1	QCU-SLIP, Slip indicator
()	2	QCU-084, 8ft. Extension cable, 4 core
()	1	LSS-WH, Pre-cut wiring and connectors for instrument pane, 5 pkgs. With wiring instructions. (rect/reg, engine ground, fuel system, tach Ignition switch)
()	1	A510-2 ignition switch
()	1	QCU-INS, instrument panel, pre-cut & powder coated with hdwr. 3 AN525-10R24 screw bolts, 5 AN365-1032 nylocs, 8 rubber Grommets, 2 x 1" anti vibration tubes, 2 AN3-24A bolts, 2 AN960-10 washers 3/16"

K: Brake and wheel package:

()	3	6" tubeless tires
()	3	6" Hegar wheels, 3 w/valve stem hole, 3 w/out hole
()	2	LSS-LG-2 axle weldment with 2ea 3/4" x .049 x 2 1/2" alum spacers. 6ea AN960-1016 5/8" washer, 2ea 5/8" thin nyloc nut 2ea AN365-1032 nyloc nut, 2ea AN525-10R10 2ea AN960-10 washer 3/16"

Challenger II - LSS inventory continued:

L: Top former assy.

()	2	LSS-TFFT former tube (15" x .50 x .035)
()	1	LSS-TFFA former angle (1" x 1" x .063 x 10.5")
()	25	SSD42SSBS 1/8" S.S. Rivets
()	1	NPN Pattern for LSS-TFFF (gusset)
()	1	Instruction sheet

M: Rudder stop assy.

()	4	AN525-10R14 screw bolt
()	5	AN365-1032 Nyloc nut 3/16"
()	5	AN960-10 washer 3/16"
()	1	AN3-24A bolt, 3/16"
()	2	LSS-PVC-1 Gray spacer (pvc) (1" x 1/2")
()	2	LSS-RS Rudder stop, white pvc (3" x 1/2" x 3/4")

N: Fiberglass gear leg fairing:

()	2	LSS-GLF fiberglass gear leg fairing
()	4	LSS-GLF-1 Material for foam inserts (fairings) - see instructions

O: Flaperon kit:

()	1	FLP-001 Flaperon slide bracket, installed at factory
()	1	FLP-002 Flaperon crank assy. Pre-assembled (1 AN4-25 bolt, 5 WNW-25 white plastic washers, 2 AN380-2-4 cotter pins, 1 AN310-4 castle nut 1/4", 1 AN365-428 nyloc 1/4")
()	1	FLP-004 Flaperon push rod, outer sleeve (28")
()	2	FLP-005 Flaperon push rod, inner sleeve (11 7/8")
()	1	CS-84 Bell crank, aileron/flaperon, installed at factory
()	1	AN365-428 nyloc nut 1/4"
()	1	AN310-4 castle nut 1/4"
()	1	NF-400 ball joint assy. (1 NF-4 ball joint, 1 AN4-7A bolt, 1 FW-25 zinc washer 2 AN960-416 washer 1/4", 1 AN364-428 thin nyloc 1/4")
()	1	AN490-HT8P rod end, threaded
()	1	3246 clevis fork, aluminum
()	5	AN380-2-4 cotter pin
()	8	SSD42SSBS rivet, 1/8" short
()	1	AN3-5 bolt 3/16"
()	1	AN310-3 Castle nut, 3/16"
()	1	NPN Instruction sheet

Section III - LSS Model

ASSEMBLY INSTRUCTIONS—Introduction

Fuselage

Objective:

At the conclusion of this section, vertical fin, rudder, stabilizers, elevators and dorsal fin will be installed on fuselage. Rudder, elevator and aileron control systems will be operative. Tail wheel, nose gear and main landing gear will be installed. Fuel tank and instrument panel installed. Fuselage covered, primed and painted. Wings and struts attached. Windshield installed and throttle assembly installed.

Tools required:

1/4", 3/16", 1/8" drill bits
Electric drill
Pop rivet gun
Protractor or angle gauge
Wrenches

Other materials: (not supplied in kits)

Masking tape
C-Clamps
Scraps of lumber (as per diagrams)

For covering instructions, refer to Section I, page 6:

How to cover the tail surfaces using 'Heat shrinkable material'

Preface to Section III

The fuselage assembly of the Challenger is nearly complete when shipped from the factory. Most bolts, nuts, washers etc. are in place. Be sure to carefully inspect all parts and assemblies for integrity before you start this section.

Control Stick hand grip

Install hand grip on control sticks (see below). Coating the inside of the grip with dish soap will help the grip slide over the tube. Insert end cap - EC1 into open end of control stick. You will need to gently tap this into position.

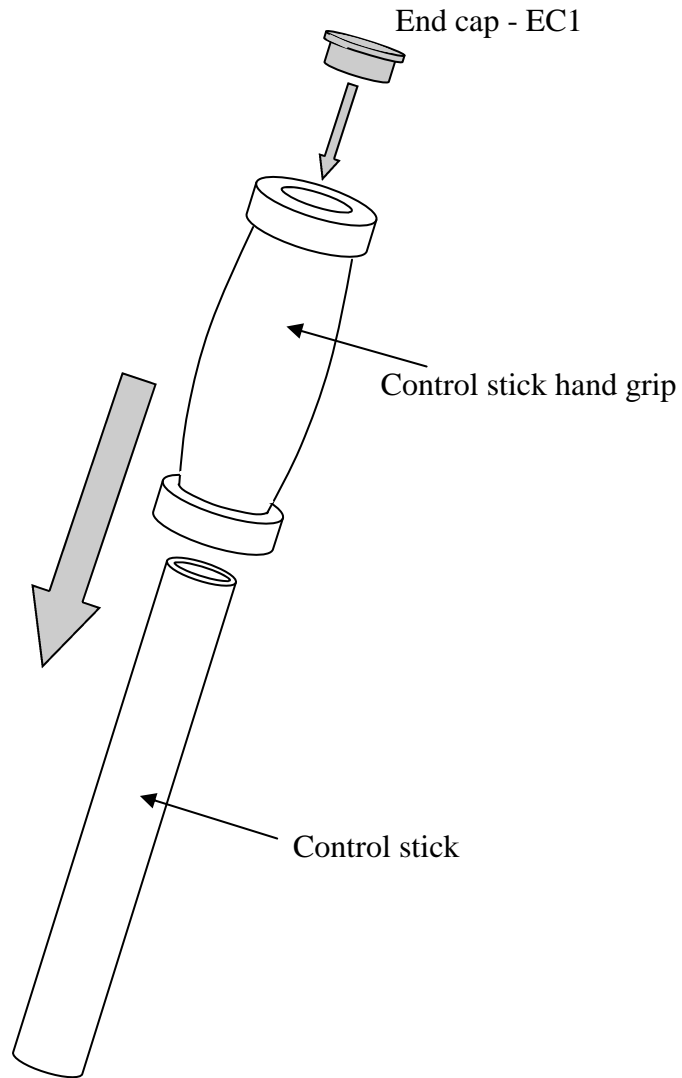

Rivet the seat bottom assemblies, front and rear former gussets

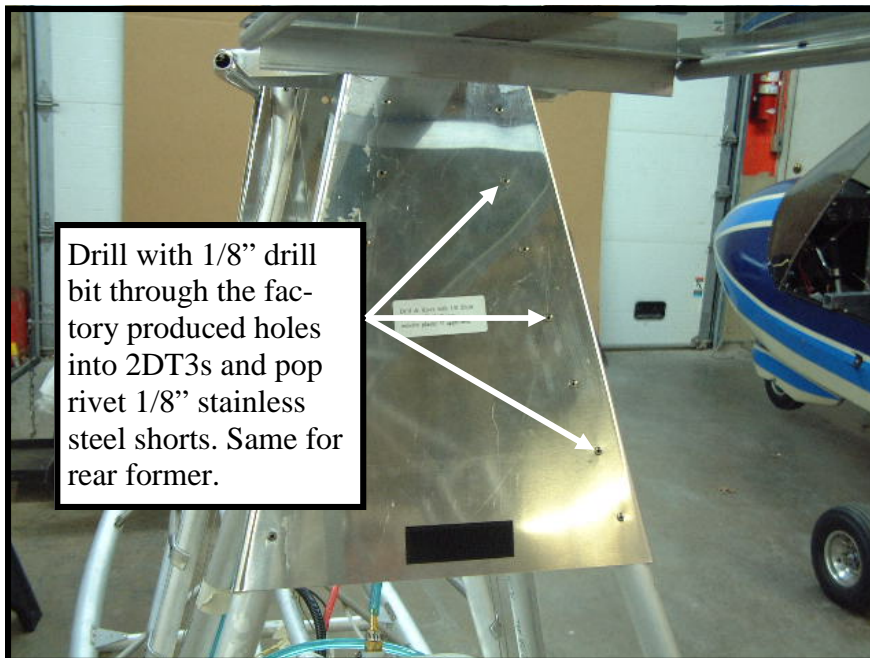
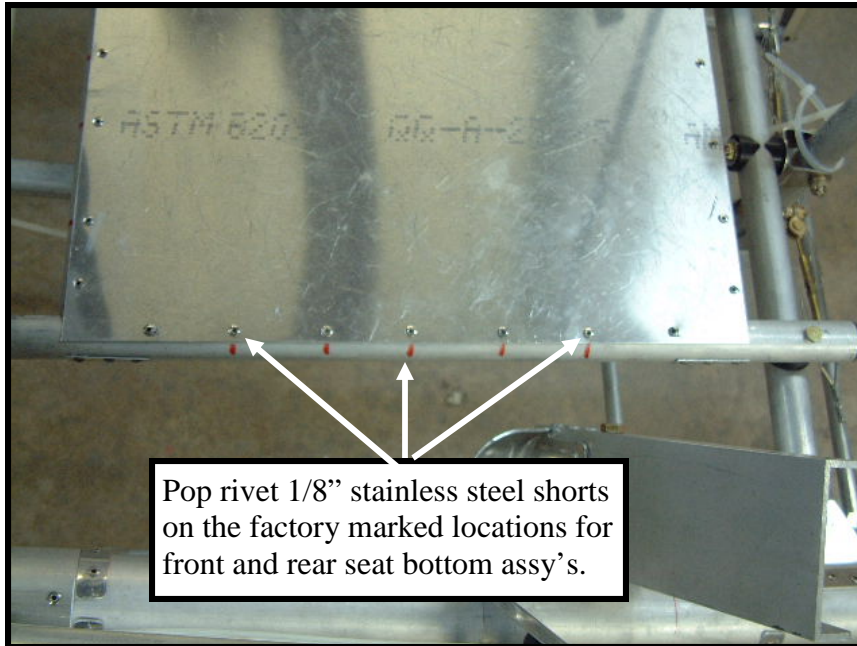

How to install Vertical Fin

NOTE: This procedure must be done BEFORE attaching the FG-99 gussets to rear of the fuselage.

1. Apply some lithium grease evenly on the inside of the tail posts
2. Place a saw horse between the two tail posts, about halfway.
3. Remove factory installed FB-11 retaining bolt and AN4-15a bolt in tail posts. See fig. 1

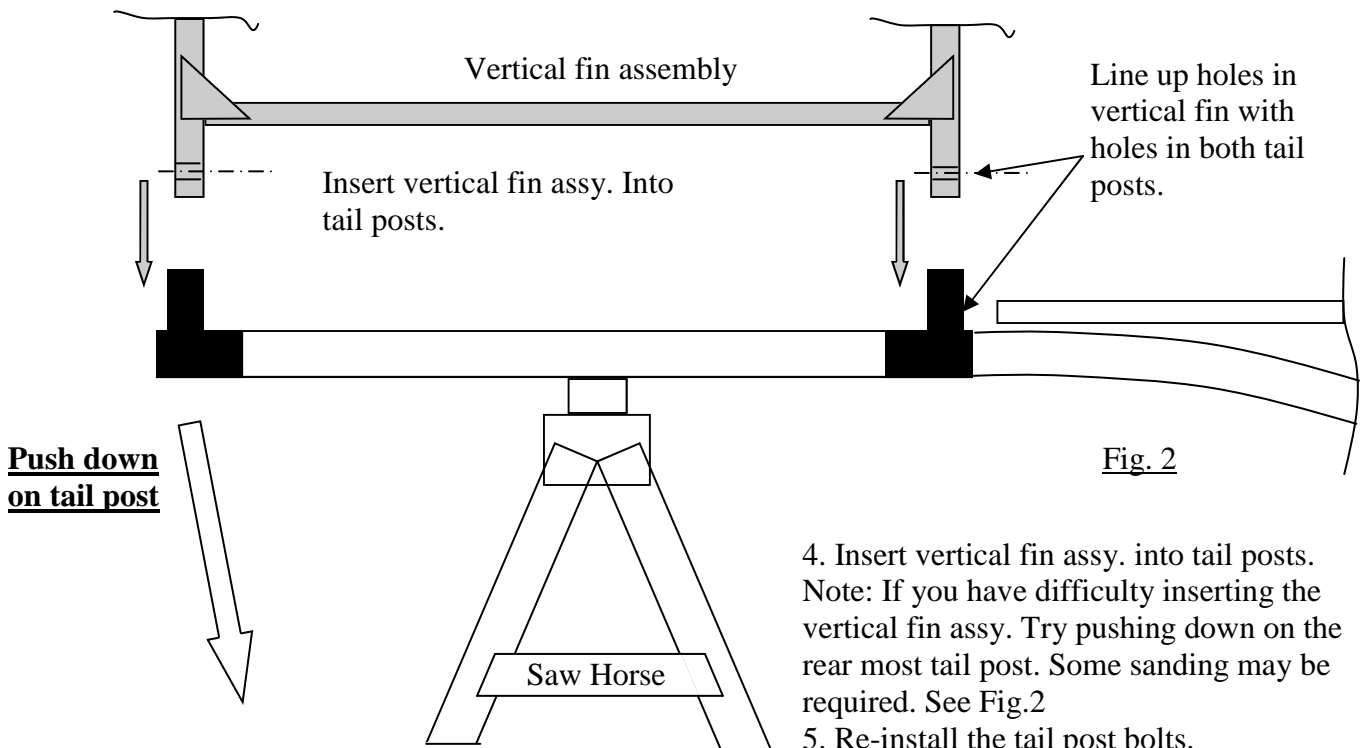
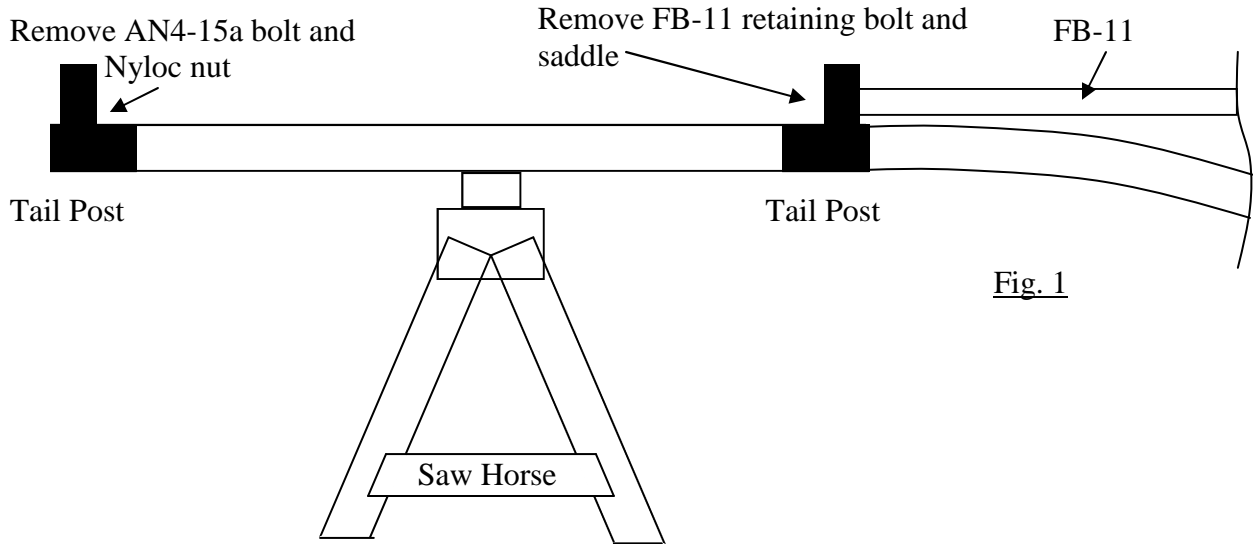

4. Insert vertical fin assy. into tail posts. Note: If you have difficulty inserting the vertical fin assy. Try pushing down on the rear most tail post. Some sanding may be required. See Fig.2
5. Re-install the tail post bolts.

How to install FG-99

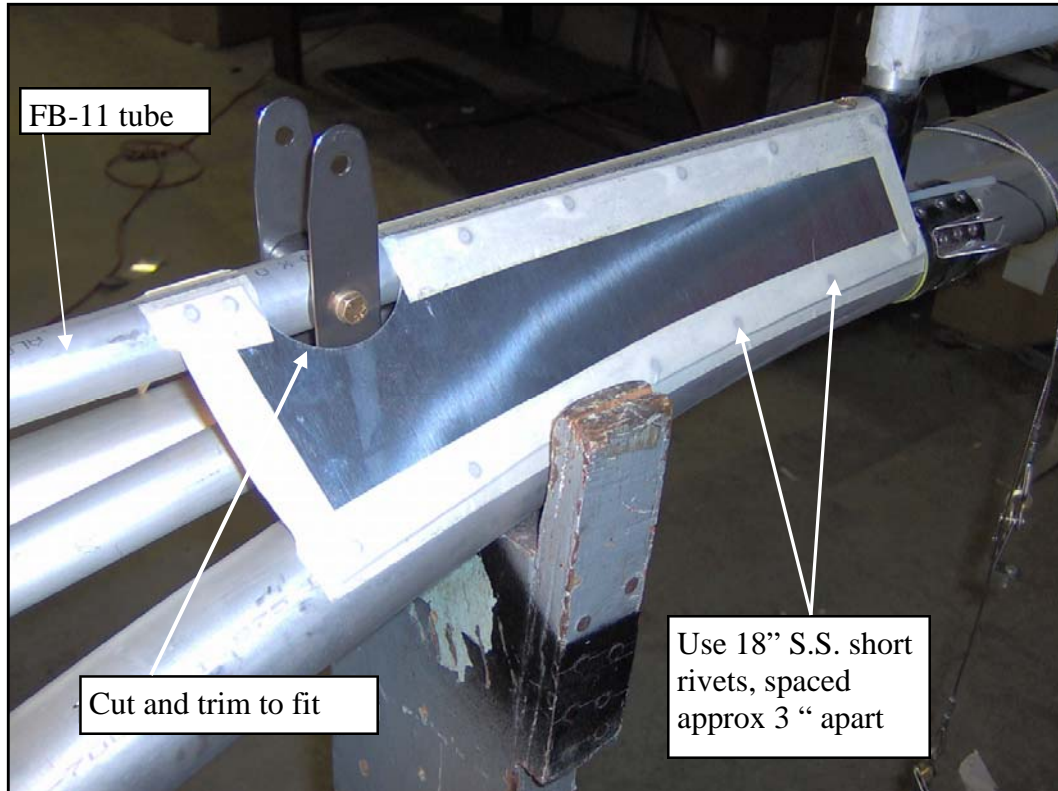

The FG-99 is designed to prevent the FB-11 tube from excessive movement. Once installed, but sure to work all edges and corners to a smooth finish. Cover the rivets and edges with tape, prior to applying glue and covering.

How to construct and install Fuel tank tray.

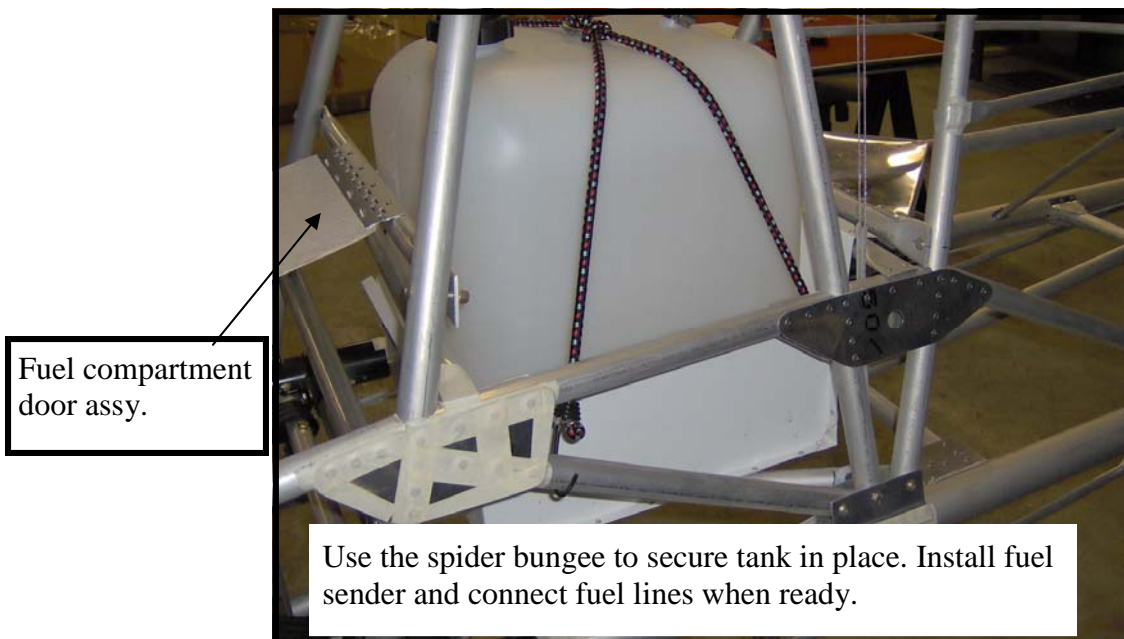
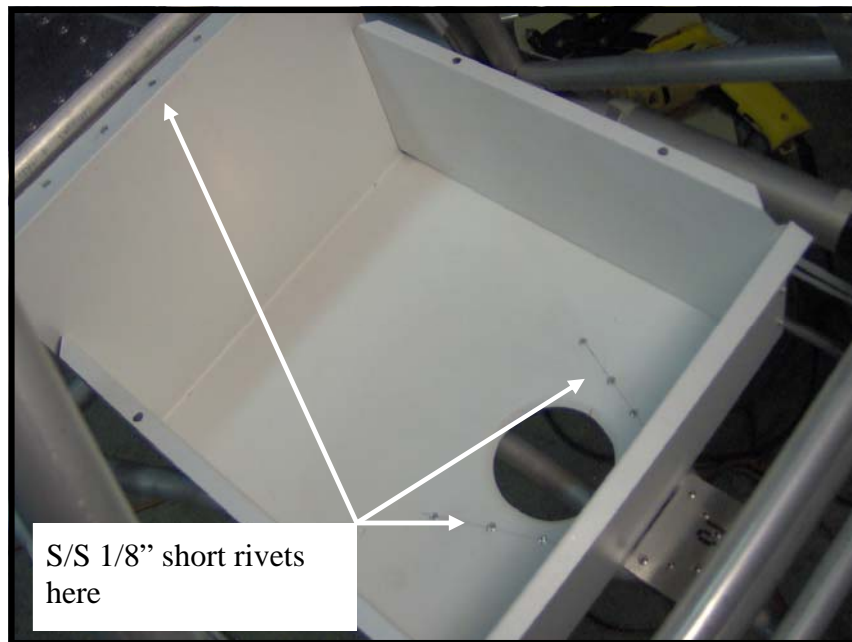
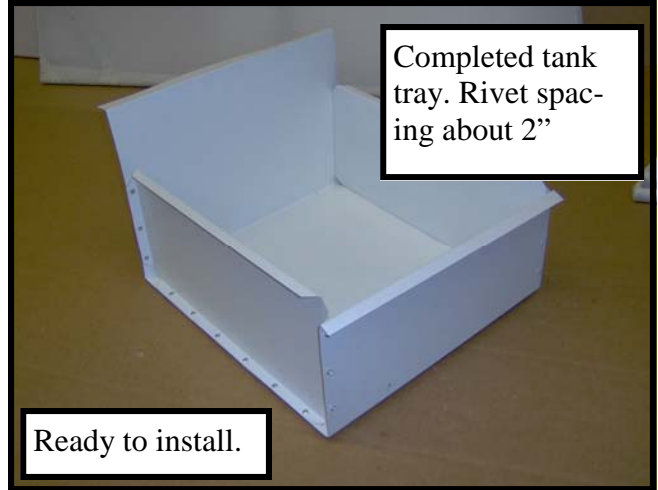
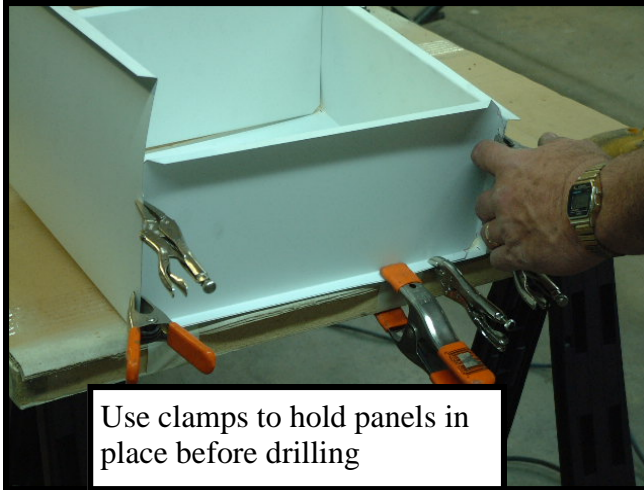

How to assemble the flaperon system

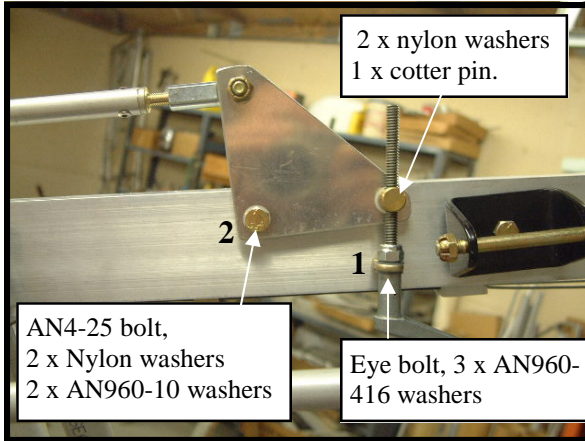

Flaperon crank assembly
RIGHT view

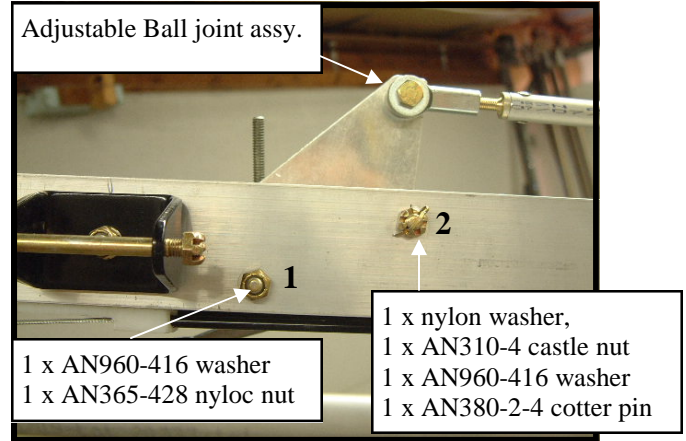

Flaperon crank assembly
LEFT view

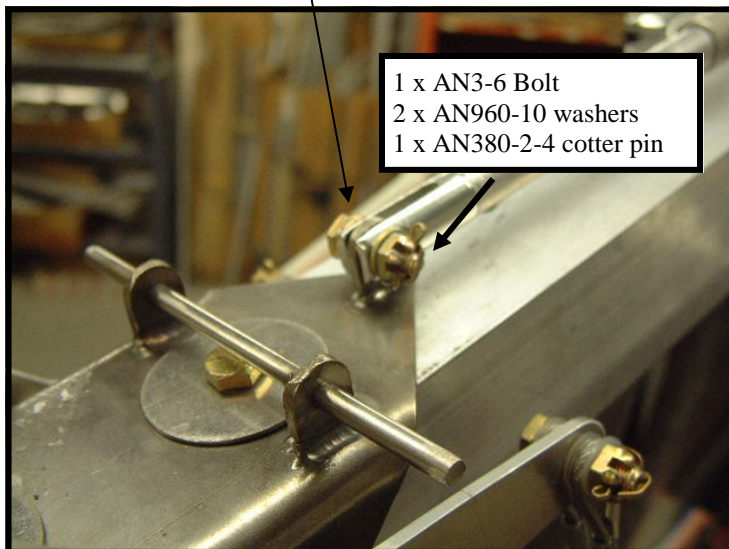
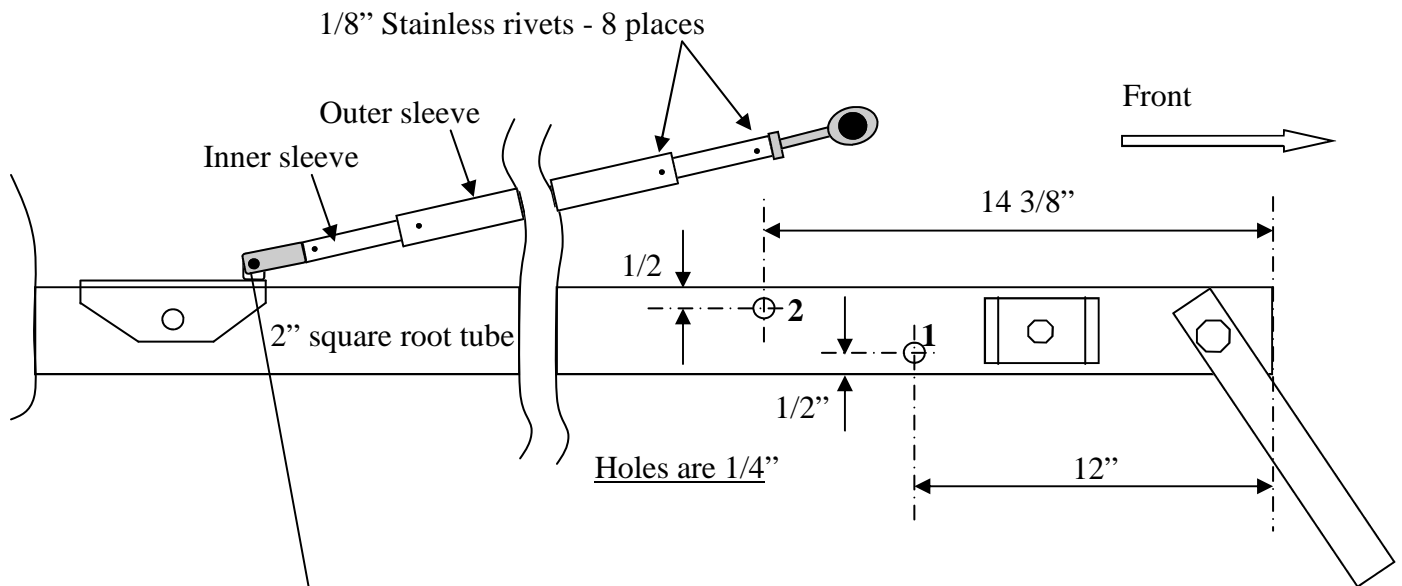

How to install the Flaperon system

Before you can assemble the Flaperon push rod, you must place the slide bracket assembly half-way between its forward and rearmost limits.

Turn the Flaperon crank handle until it reaches its limit. Then turn it in the opposite direction and count how many revolutions until it reaches the opposite limit. Half that number and crank the Flaperon to that point. This is usually about 10 revolutions.

The slider and crank assembly are now set in the middle position and ready for installation of the push rod.

Assemble the push rod by inserting the two inner tubes into the outer sleeve. The ball joint end must be attached to the triangular bracket on the crank assembly and the clevis fork must be attached to the tab on the slider bracket. Some trimming of the inner tubes may be required in order to fit correctly in the outer sleeve.

Once you are happy with the location of inner and outer sleeve, mark and rivet. Use 1/8" stainless steel rivets (shorts).

Oil mechanism wherever it slides, pivots or screws.

Mark airspeed indicator upto 55mph. This is the maximum speed at which the flaperons can be used in the DOWN position. This applies to all Challenger models. Up (reflex) position can be used at any speed. If properly set up the flaperons should go up 10 Deg and down by about 15 to 20 Deg. You may have to re-adjust your aileron push rods to get optimum results.

You can increase the amount of flaperon and aileron by drilling a new 1/4" hole in the aileron horn as in the sketch below. This new hole should be 3/4" below the factory drilled hole. Be sure you still have full aileron movement with flaperons set in their full up and full down positions.

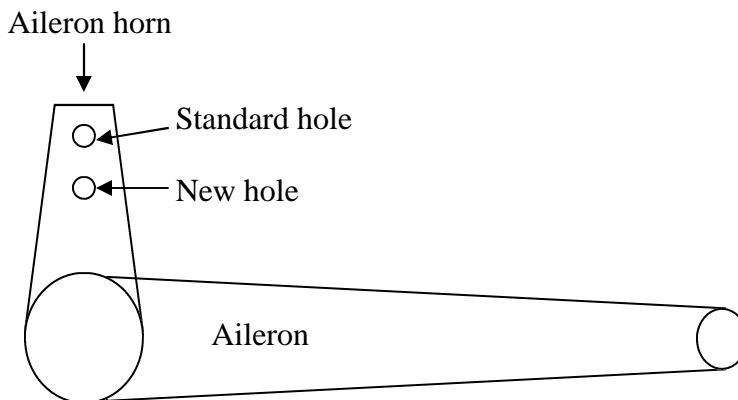

Suggested wiring diagram for Rotax 447/503 Dual CDI, Dual carbs.

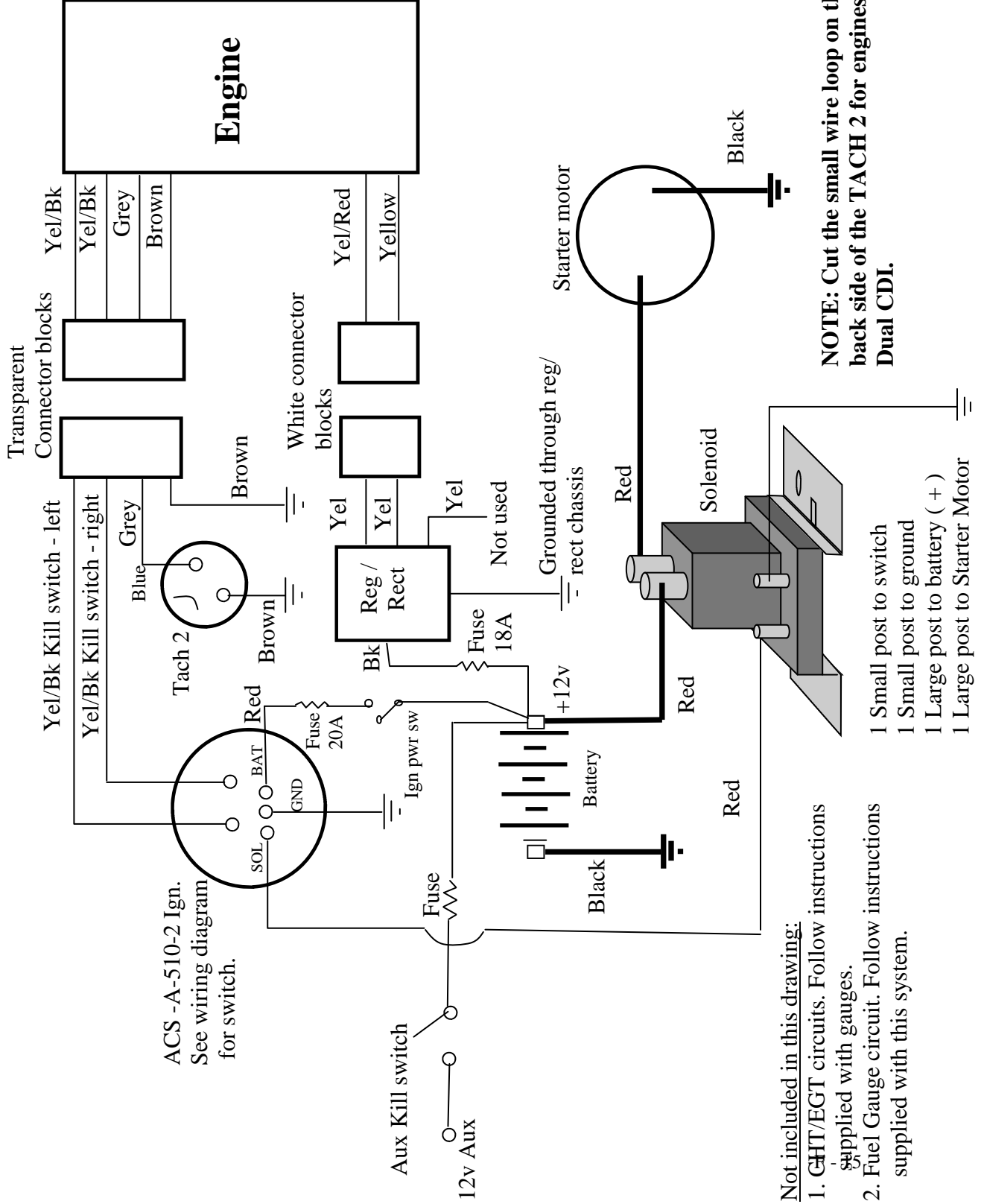

Not included in this drawing:

1. GHT/EGT circuits. Follow instructions supplied with gauges.
2. Fuel Gauge circuit. Follow instructions supplied with this system.

NOTE: Cut the small wire loop on the back side of the TACH 2 for engines with Dual CDI.

- 1 Small post to switch
- 1 Small post to ground
- 1 Large post to battery (+)
- 1 Large post to Starter Motor

WIRING LOOM COMPONENTS FOR LSS

<u>Wire color</u>	<u>Location</u>	<u>Length and associated connectors</u>	
<u>REGULATOR-RECTIFIER</u>			
			M/F = Male/Female
BLACK	REG/RECT (inset fuse)	11 ft	3 M/F Connectors - 1 lg, 1 sm. ring connector
YELLOW	REG/RECT	1 ft	1 M/F Connector
YELLOW	REG/RECT	1 ft	1 M/F Connector
THE BODY OF REG/RECT IS GROUNDED ON CONTACT WITH AIRCRAFT.			
<u>IGNITION SWITCH</u>			
YEL/BLK	KILL SW LEFT	11 ft	1 M/F & 1 sm ring connector
YEL/BLK	KILL SW RIGHT	11 ft	1 M/F & 1 sm ring connector
RED	IGNITION LIVE	11 ft	1 sm & 1 lg ring connector
GREEN	IGNITION GRND	3 ft	1 sm & 1 lg ring connector
RED	SOLENOID LIVE	11 ft	1 sm & 1 lg ring connector
<u>TACH 2</u>			
GREY	TACH 2	11 ft	1 M/F Connector
GREEN	TACH 2 GRND	3 ft	1 M/F Connector & 1 lg ring connector
<u>ENGINE GOUND (See note below)</u>			
BROWN	ENGINE GRND (SEE NOTE)	3 ft	1 lg ring connector
<u>FUEL SYSTEM</u>			
BLACK	FUEL PROBE	8 ft	2 M/F Connectors
RED	FUEL PROBE	8 ft	2 M/F Connectors
YELLOW	FUEL PROBE	8 ft	2 M/F Connectors

CHT/EGT interconnect

These 4 core wires are fitted with connectors and packaged individually. Please refer to the instruction supplied with the CHT/EGT gauges for installation of the interconnect.

NOTE:

BROWN WIRE FROM ENGINE TO BLOCK CONNECTOR IS 'GROUND'. IT IS ADVISABLE TO GROUND THE ENGINE BLOCK TO THE AIRCRAFT FRAME WITH 4ga 'STARTER MOTOR GROUND WIRE' (3FT SUPPLIED WITH STARTER MOTOR PACKAGE) IN ADDITION TO BROWN WIRE GROUNDING.

THE CONNECTORS HAVE NOT BEEN ATTACHED SO THAT YOU MAY TRIM WIRES OR RE-ROUTE WIRES TO SUIT YOUR NEEDS.

FOR ATTACHING WIRES TO THE BLOCK CONNECTORS, PLEASE REFER TO THE MANUAL YOU RECEIVED WITH YOUR ENGINE FROM ROTAX. THE CONNECTORS AND BLOCKS FOR THE ENGINE ARE LOCATED IN ONE OF THE CARBURATOR BOXES.

How to construct circuits for LSS - Example

This example of how to construct a circuit is typical for all circuits supplied with the LSS. Obviously, some thought must go into each individual circuit as there are slight differences for the construction and routing. You may also be considering such things as 'hot boxes' or 'gang connectors'. The options are many. We have chosen to show you the simplest and easiest method within these instructions.

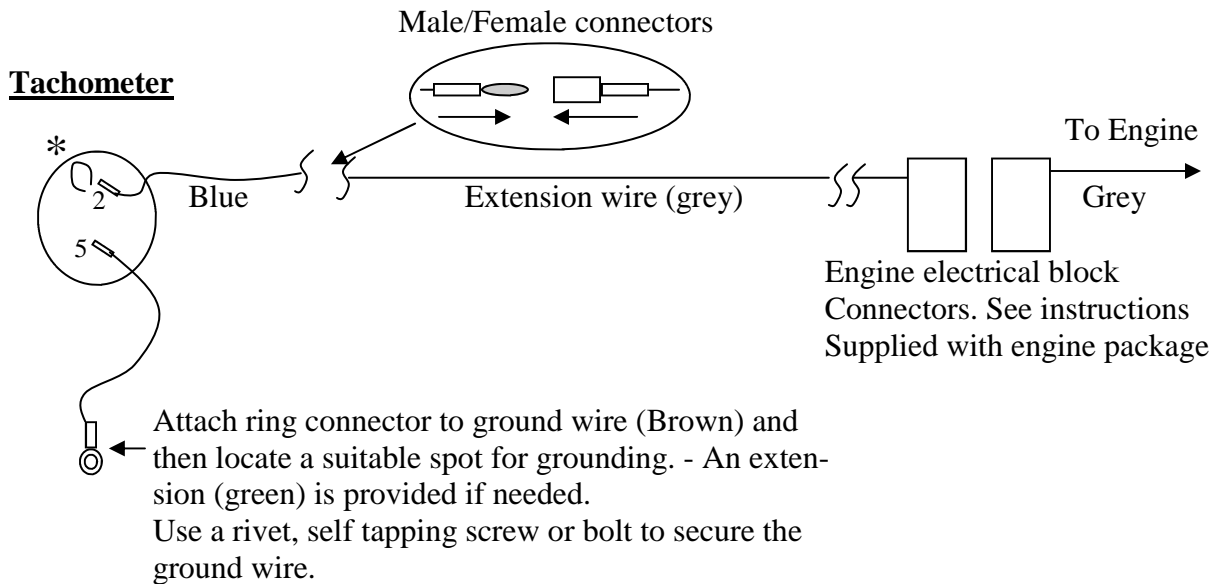

*- If you are running a 'Dual Ignition' engine, you must cut this wire loop

Note: The Tachometer is supplied with a wiring harness. The default wire colors are Blue and Brown. Please note this on your aircrafts circuit diagram.

How to connect the 3 phase reg/rect.

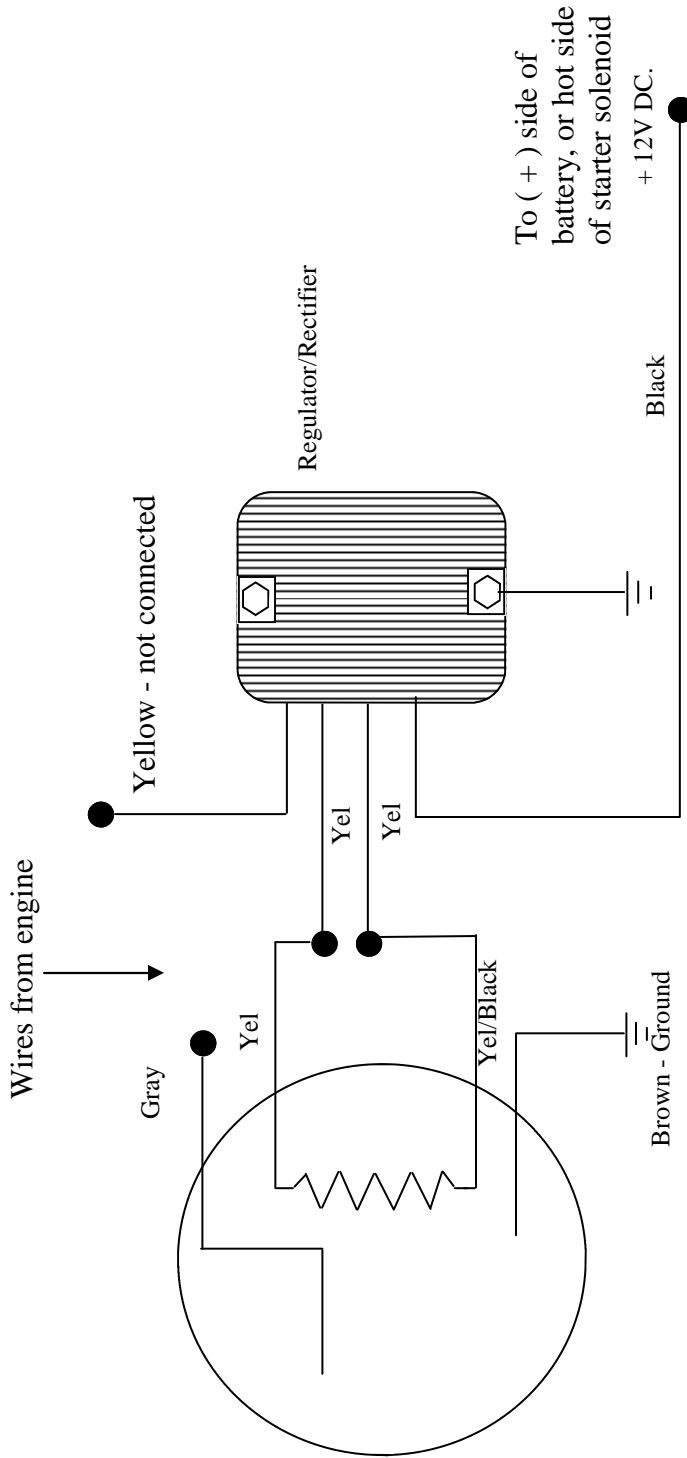

Special 3 phase regulator/rectifier unit connects directly to lighting coil. Produces 12V DC. current. Ideal for charging batteries and other accessories requiring 12V DC. Easy four wire hook-up. 'Fins help dissipate heat during full load operations. This unit does not require a 'minimum load'. The yellow wire not used can be used as back-up circuit or to directly power gauges and other accessories requiring 12V DC.

EGT/CHT Installation

Wiring harnesses (extensions) are assembled and complete for the CHT/EGT circuits. Simply connect the ends as per instructions supplied with gauges.

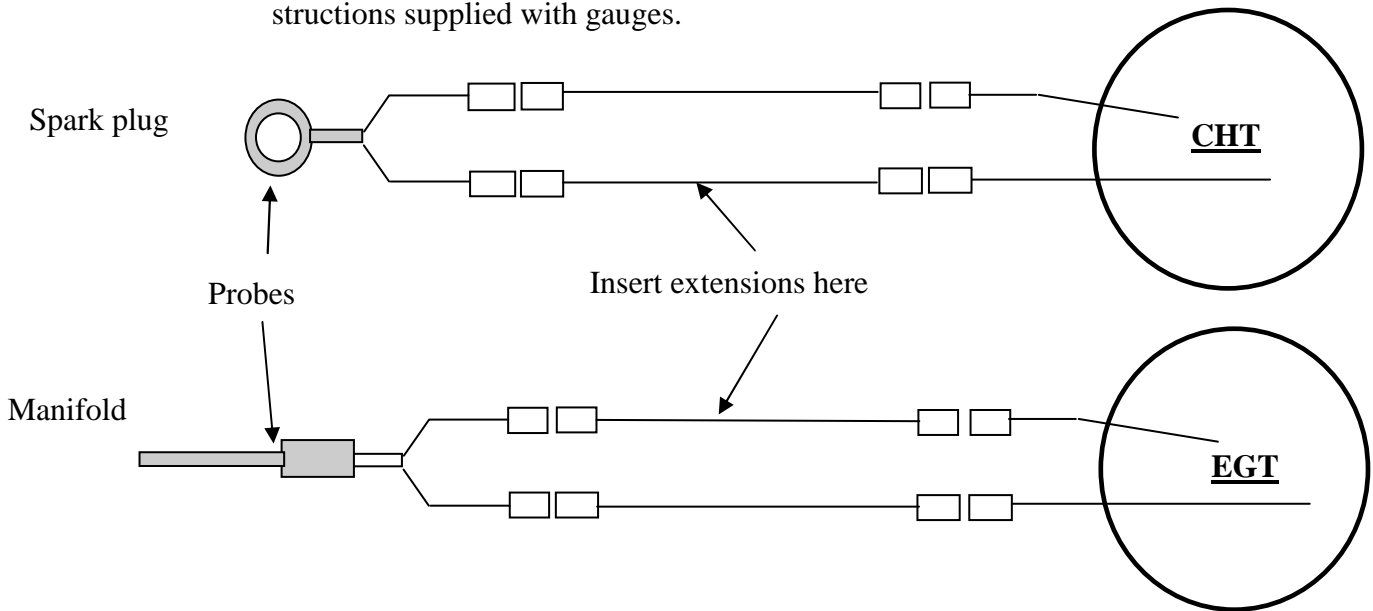

Wrap at least 3 times around spark plug lead.

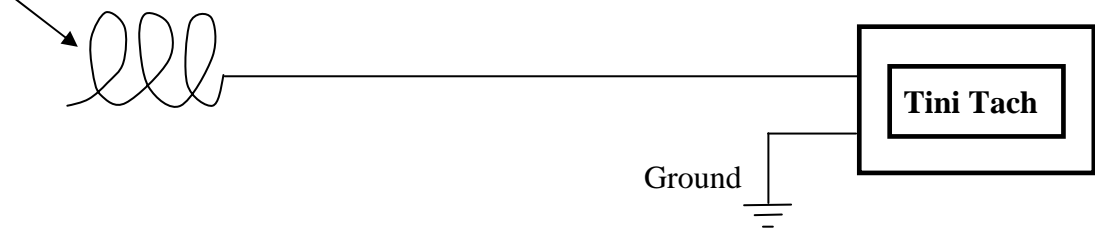

Follow the installation instructions that accompany these instruments.

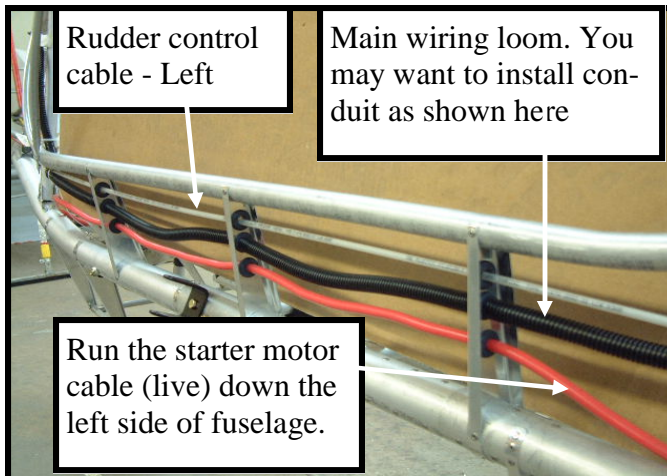

Left side rail - Looking forward

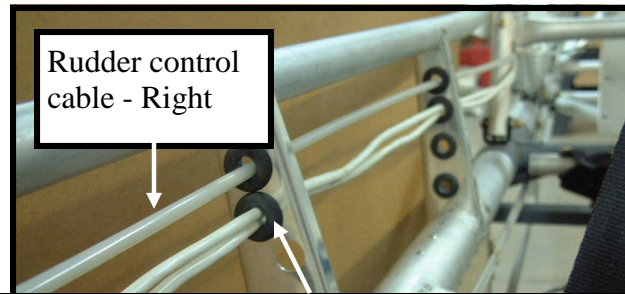

CHT/EGT interconnect cables. Same side as fuel lines. For installing all cables we drilled 5/8" holes and used rubber grommets available from most hardware stores.

Right side rail - looking rearward

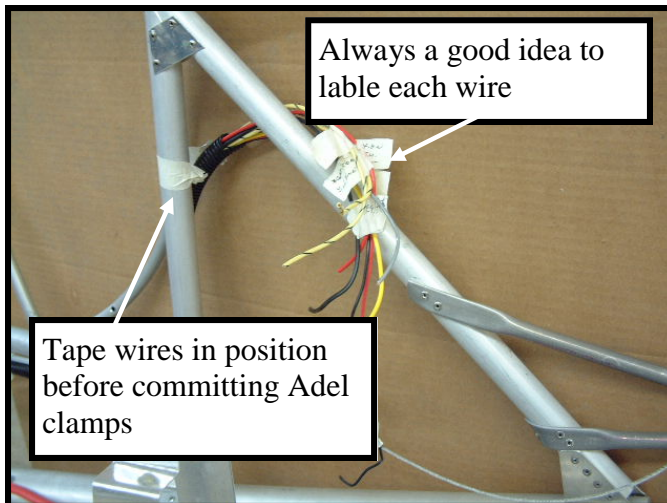

Front of fuselage - Inside left side

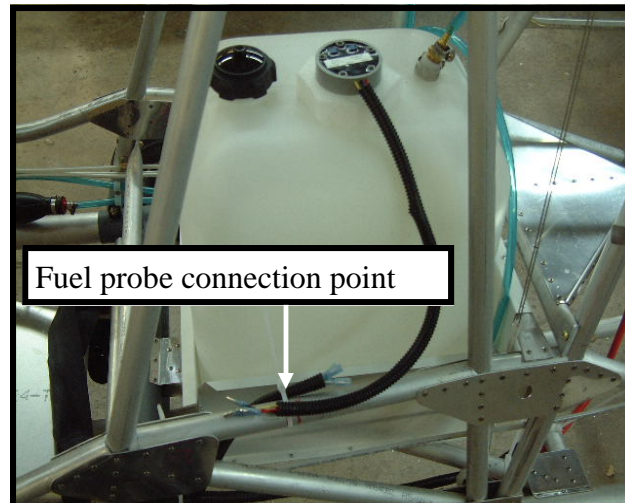

Fuel tank assy. Probe connection

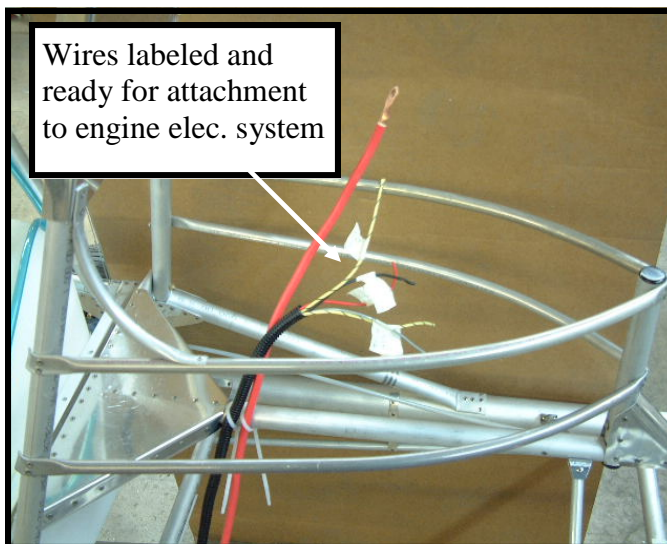

Rear of Fuselage - Under engine

Once the wire loom has been installed, determine where you are going to place your instruments in the panel. Adjust the wire loom length as required, you may need to trim the wires at this point. Each circuit is provided with the correct connections required for its intended function. When the instrument panel has been installed, attach the end connectors to the wires.

Follow the instructions provided with the engine for connections to the engine electrical circuits and block connectors.

How to install LSS-Fuel system

<u>Inventory</u>	<u>Part Number</u>
1 Inline fuel shut off valve 180deg, 1/4" dia barbs.	LSS-120S
8 Nylon fuel line clamps	3360S
8 Alum. Rivets 3/8" long	AD64ABS
14 Small hose clamps	HC-FL
1 Squeeze bulb	PRIMER
1 Inline fuel filter	FILTER
13ft Blue fuel line.	FUEL-L

Refer to the following photographs for installation procedure.

NOTE: Fuel filter to be inserted into fuel line close to fuel pump near engine. Make sure you have the filter the right way round by looking at the arrow on the casing. Arrow indicates direction of fuel flow.

The fuel pump connections and carb connections will be done later when the engine is installed.

The fuel shut off switch is in the ON position with the lever DOWN. The OFF position is with the lever pointing OUTBOARD.

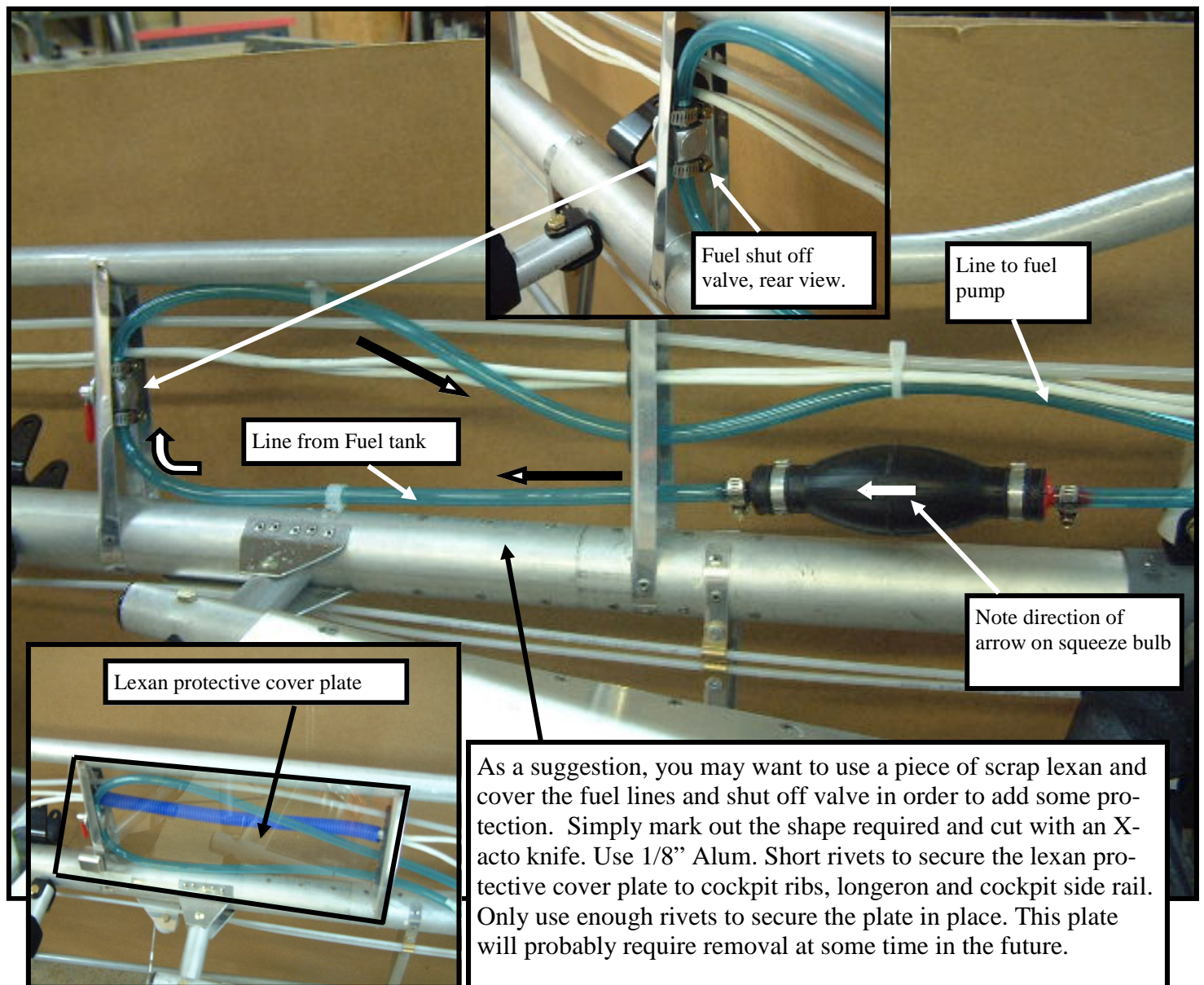
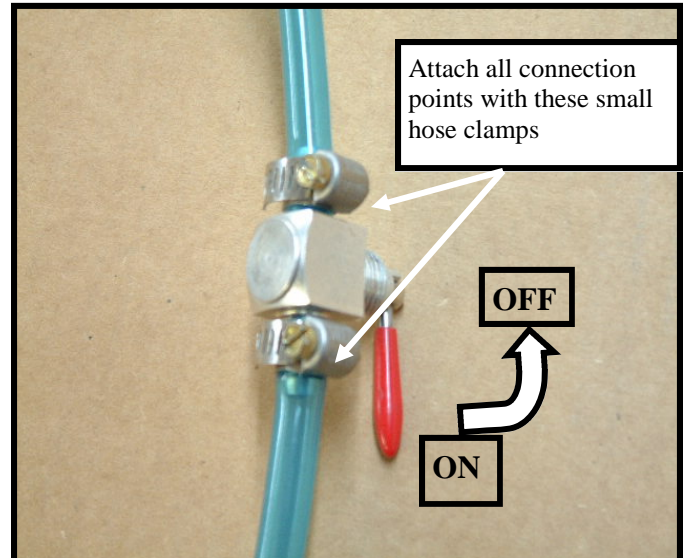
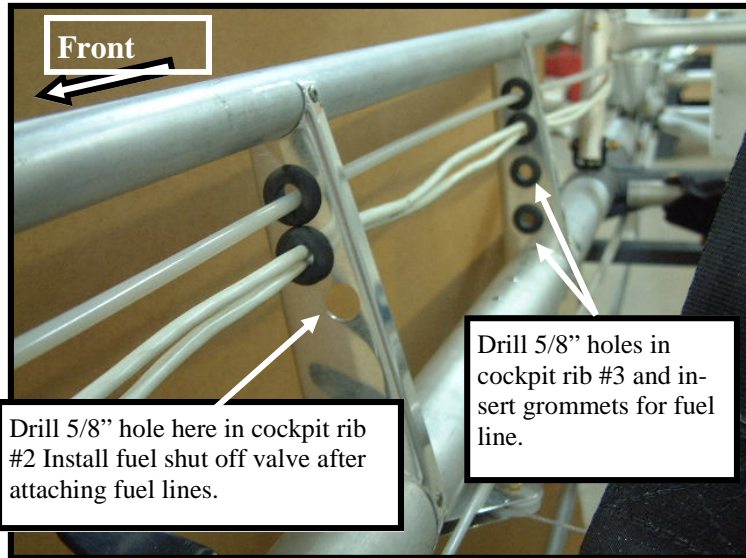

How to run the hydraulic brake lines

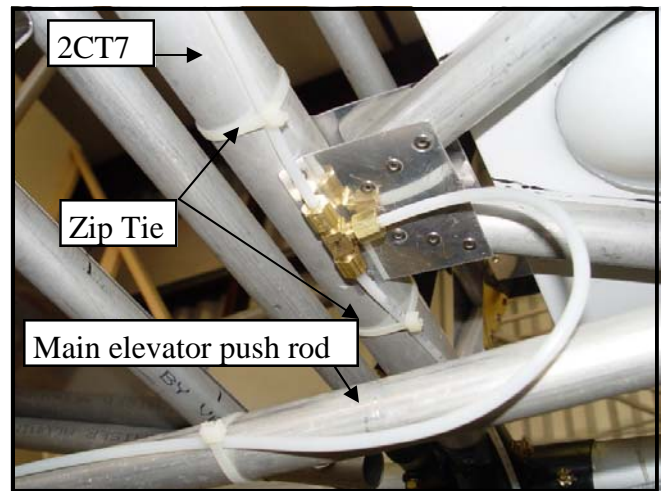
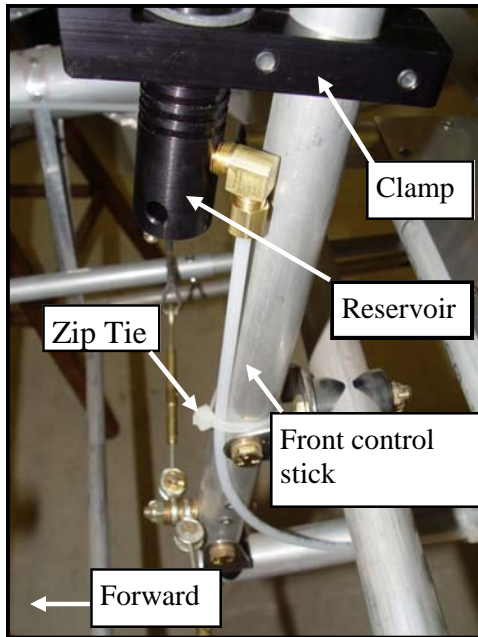

Connect all hydraulic lines as per instructions supplied with the brake kit. Make sure you leave enough line to reach the left and right brake calipers, with enough to trim as necessary. Note how the line is looped to enable full range of movement from the control sticks and main elevator push rod.

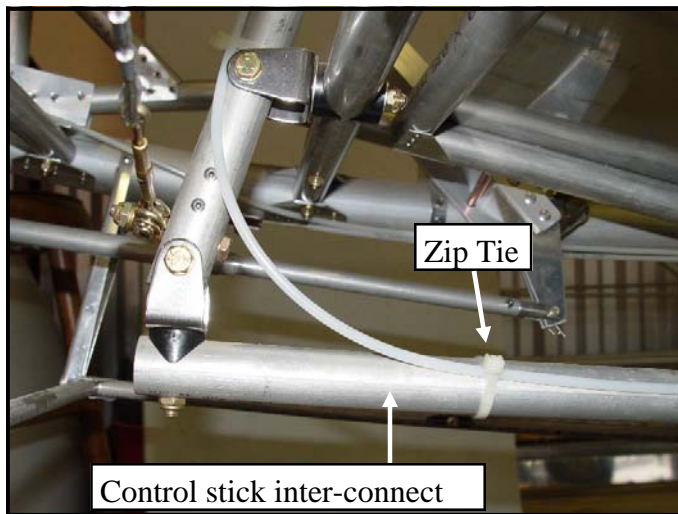

Make sure you leave enough 'slack' in the hydraulic line to allow for full range of movement from front and rear control sticks.

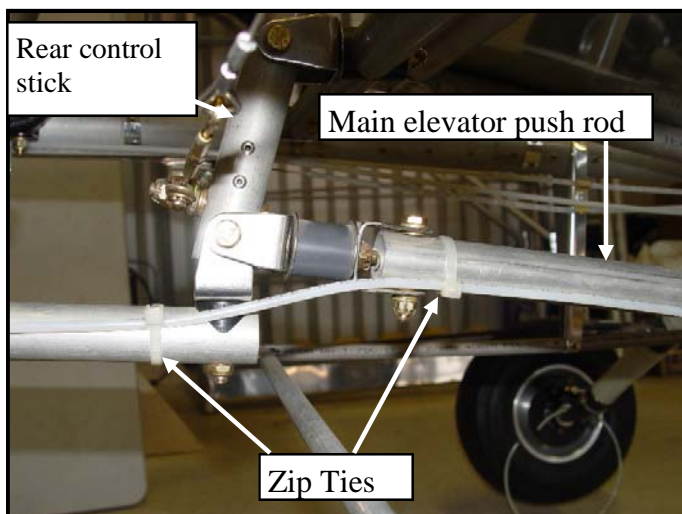

For Hegar Brakes installation, please refer to the instructions named 'Hegar 6" Disc Brakes Ultralight Instructions' Supplied with your brake kit.

QCU Modular Instrument panel

<u>Quantity</u>	<u>Part number</u>	<u>Description</u>
1	QCU-INS	Pre-cut and shaped instrument panel
3	AN525-10R24	Screw Bolts
5	AN365-1032	3/16" Nyloc nuts
8		3/16" I/D Rubber grommets
2		1" Rubber Anti-vibration spacer
2	AN3-24A	3/16" bolts
2	AN960-10	3/16" washers



Shown here is an example of instrument choices you may want to consider. Our customer has opted to fit a transponder which will be fitted into the empty hole before final installation.

QCU instrument panel showing EIS.

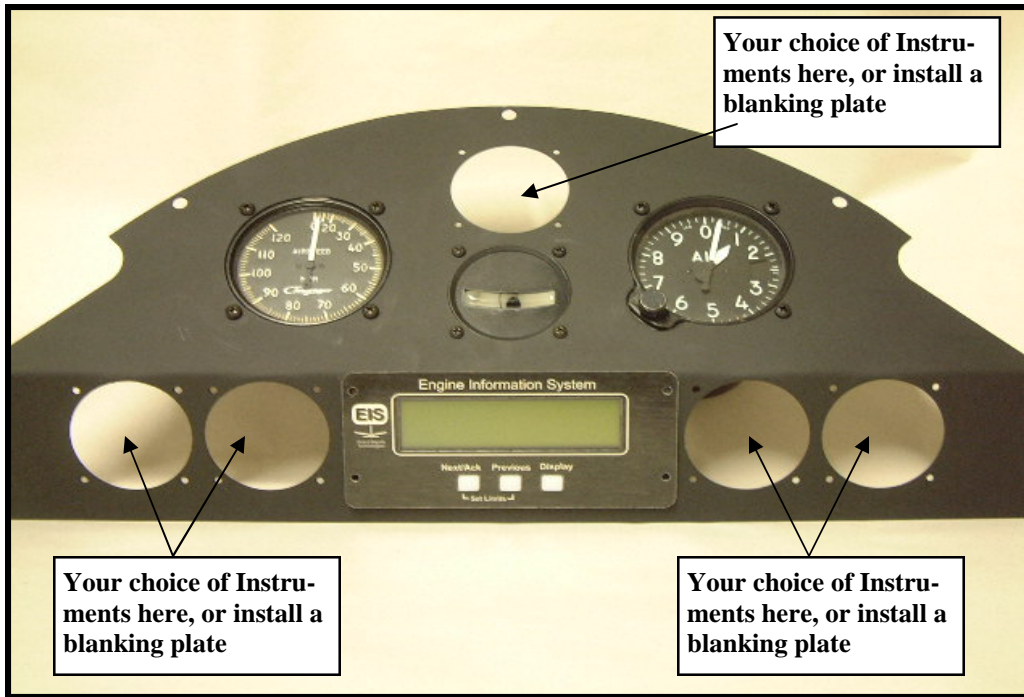

This example of the QCU panel with EIS installed shows how versatile the panel is. You can opt for a host of additional instruments to compliment the package that comes with the LSS, or you can use blanking plates to cover over any unused instrument attach points.

It is, however, important that the slip indicator (shown above the EIS) be installed in that position. Any other instrument at this location will probably make contact with the EIS.



Examples of blanking plates. These are available from most reputable aircraft supply Co's.

Installation instructions

This panel can be configured to accommodate your preferred combination of instruments. For example: The panel comes with a pre-cut location for an E.I.S. If you decide against installing an E.I.S. you can easily mount a backing plate against the E.I.S. cut out. Rivet or screw the backing plate in place and install the combination of instruments you want or leave it blank. Instrument locations indicated with dotted lines are shown for example only, you decide what you want and where you want it.

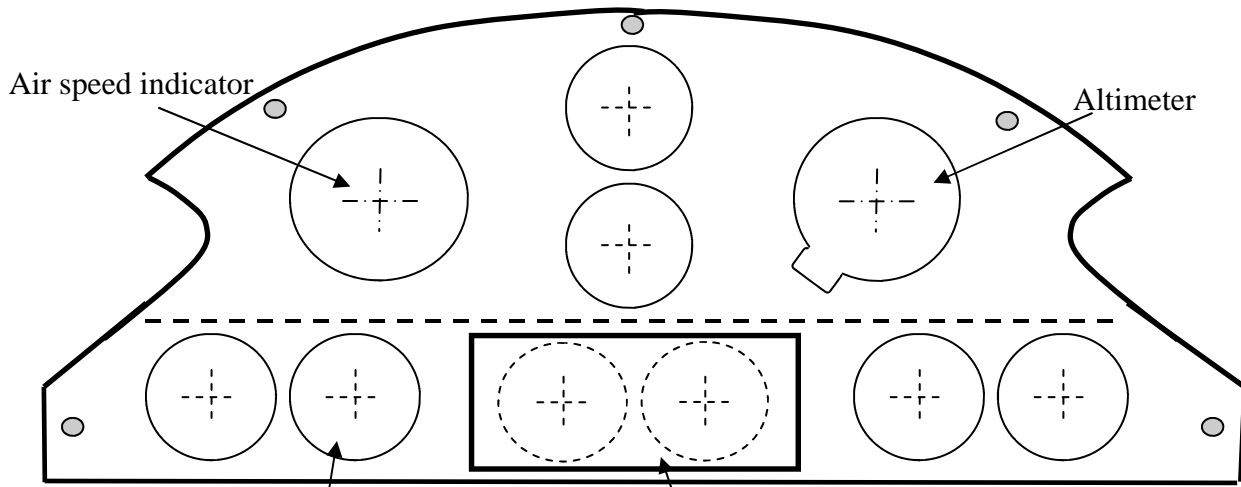

Any combination of instruments can be added.

Optional E.I.S. - standard analogue instruments or blanking plate.

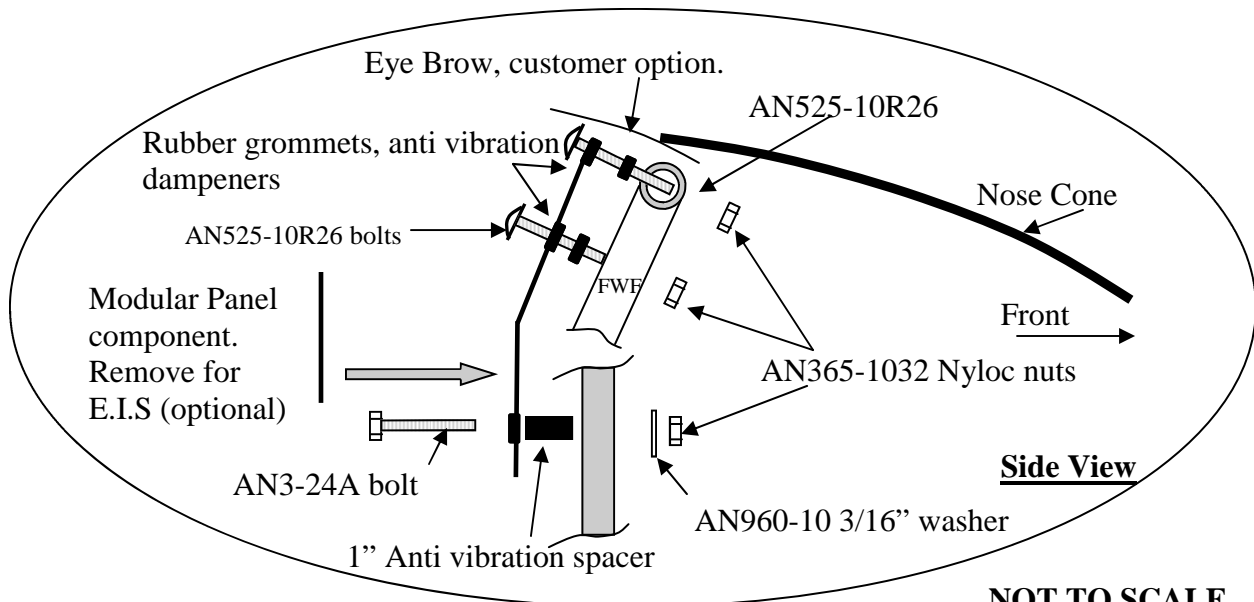

NOT TO SCALE



Use masking tape to secure the panel in place and mark the location on FWF for panel mounting hardware.



Drill 3/16" holes at these points and install all bolts and anti vibration grommets.

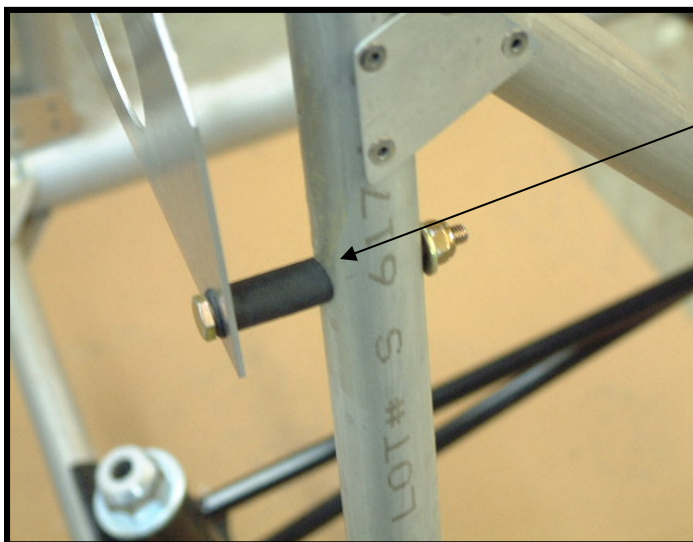

This picture shows how the 1" anti vibration rubber spacer should look after installation.

Once the final fit has been completed, you can now remove the panel and spray paint, cover or coat it. Be careful of paint build-up in the instrument recess holes. This might make it difficult to fit instruments.

Your instrument panel will arrive powder coated. You may have to remove coating on the inside of drilled holes for bolts to fit.

Rudder pedal interconnect pushrods

Tip: Remove this bolt from the longeron before covering the fuselage. Once the fabric is on and painted, carefully cut or burn out the hole at this location and re-install the bolt, castle nut and cotter pin.

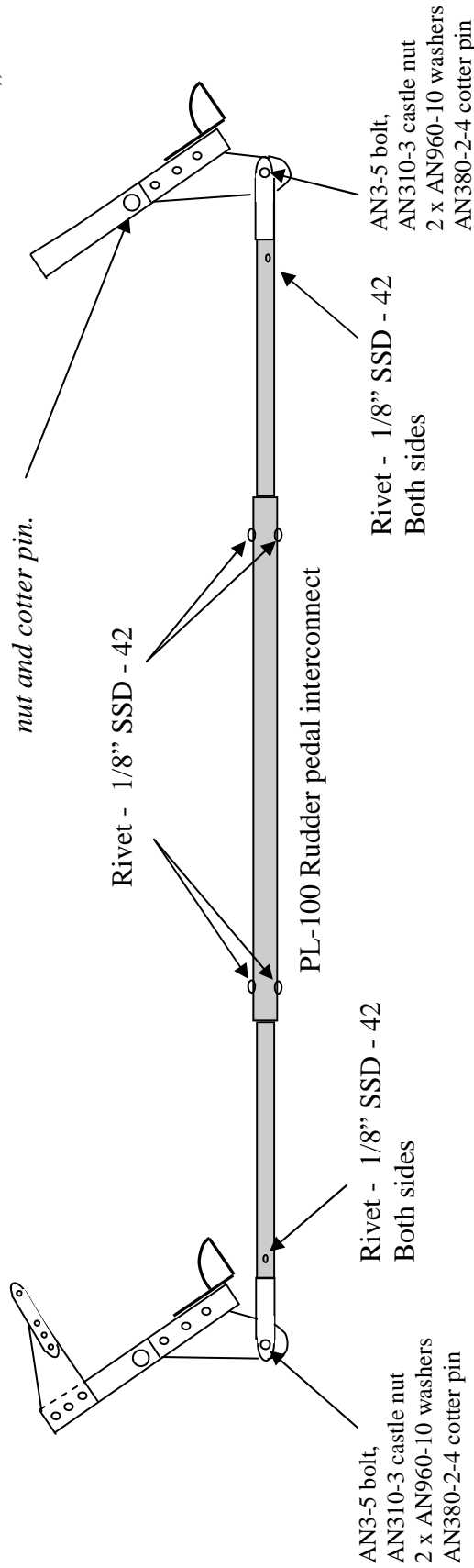

The rudder pedal interconnect pushrods are assembled and riveted in the same manner as the elevator pushrods. Be sure the front pedals are in a neutral position and then position the rear pedals to determine the proper length for the pushrods (as above). We find it best to sit in the rear cockpit and position the pedals to where they are most comfortable.

Top Fabric Former Assembly instructions

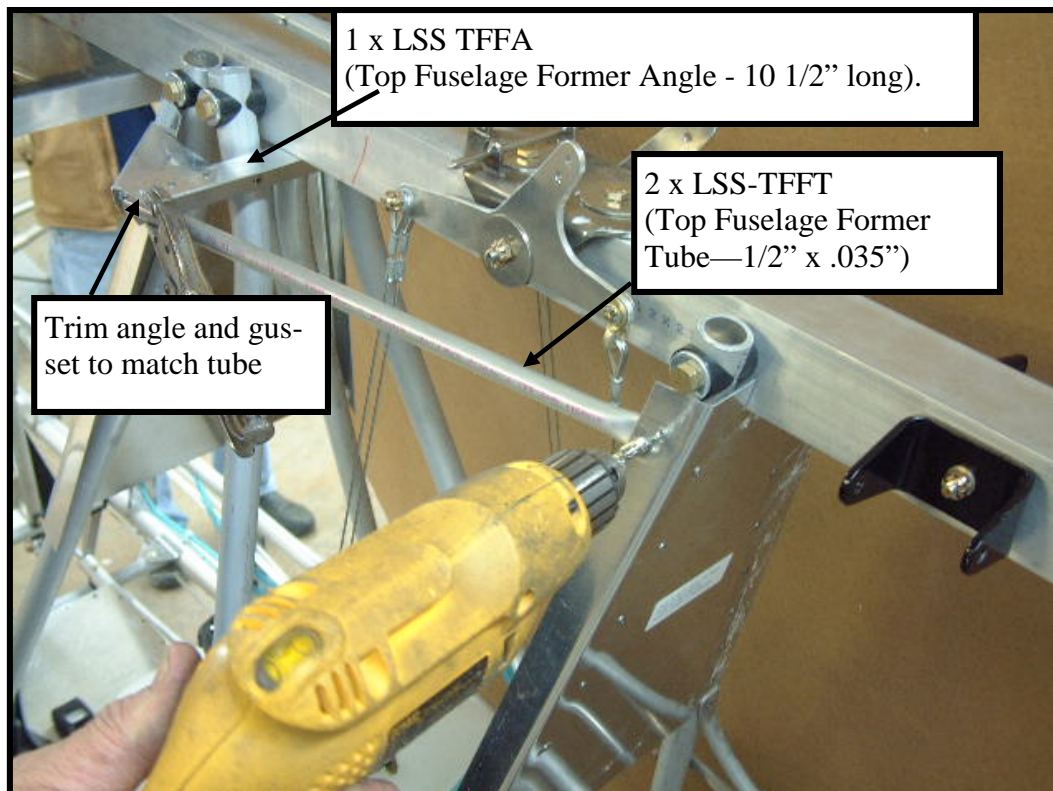
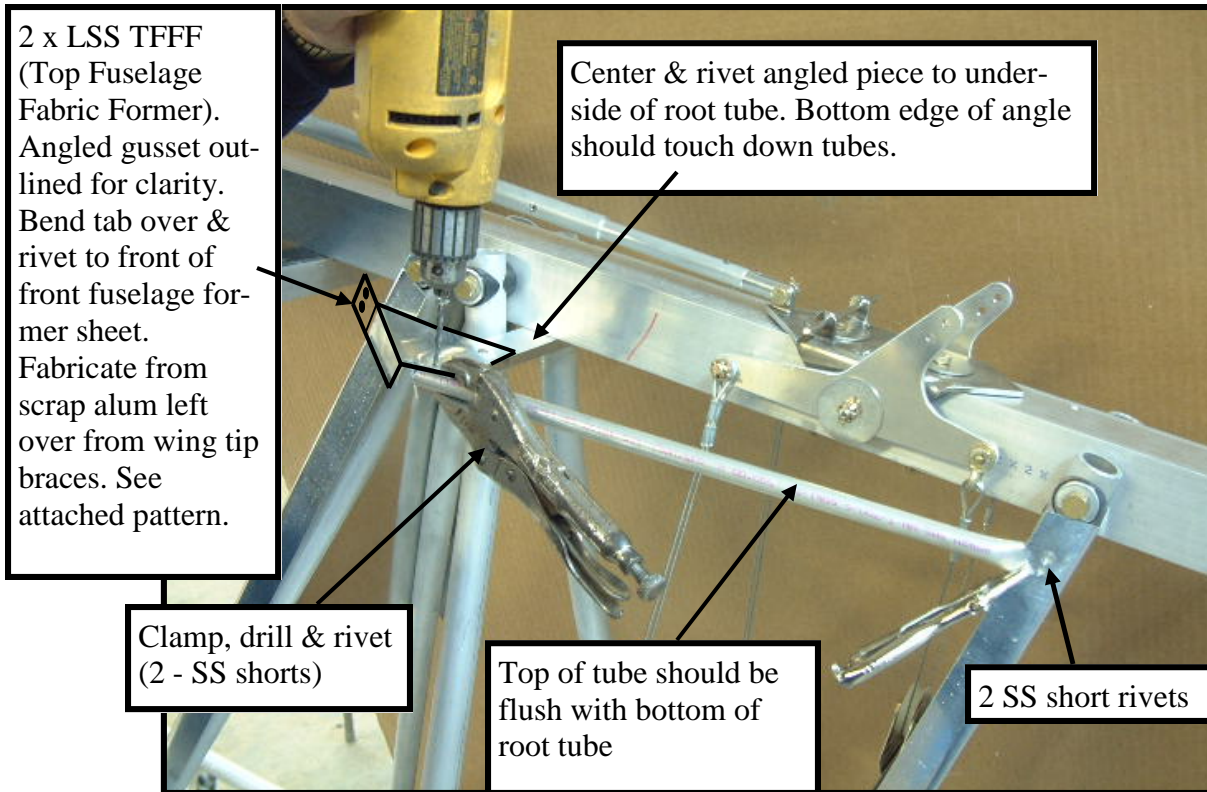

Cut out patterns for LSS-TFFF

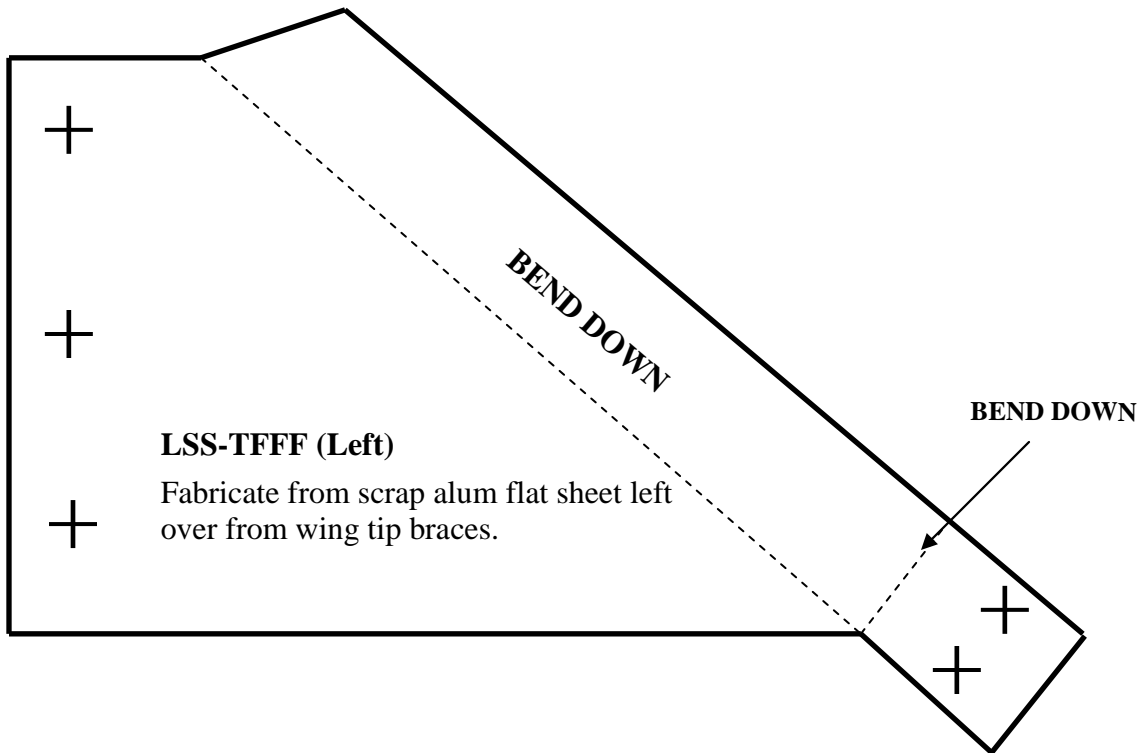

Inventory list for Top Fabric Former assembly.

- 20 SSD42SSDS Stainless rivets short
- 4 SSD44SSDS Stainless rivets long
- 2 LSS-TFFT (1/2" x .035) tubes
- 1 LSS-TFFA (10 1/2" angled stock)
- 1 Instructions with pattern for LSS-TFFF

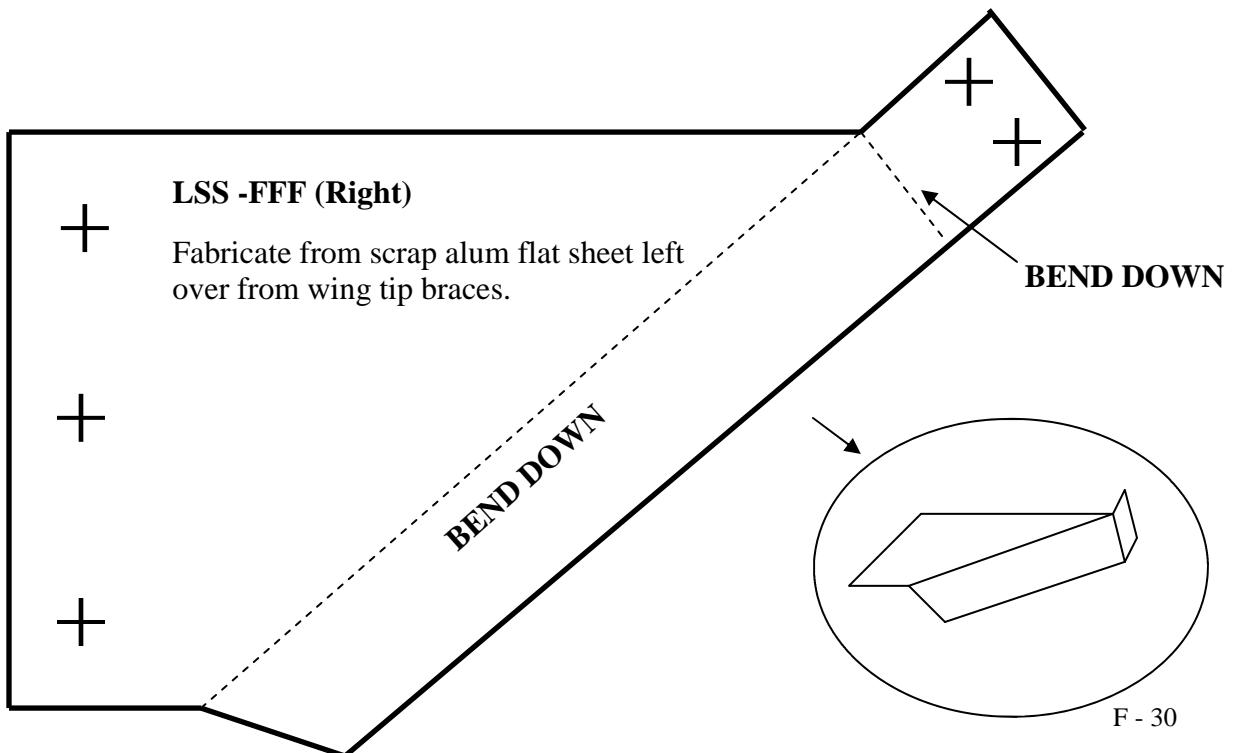

How to install the nose cone



Rivet the 20" long x 2 1/2" wide angled alum. gusset to the first stringer assembly cross tube. The short angled piece goes on the front side of the cross tube and is vertical (up). Rivet on the front side of the cross tube and into the gusset. Slide the top of nose cone over the FWF and the bottom of nose cone over the 1/2" stringers on the bottom of fuselage. Some adjustment will be required to get the nose cone in the position you want it. It is a tight fit ! Once you have it located, use spring clamps to hold it in place.

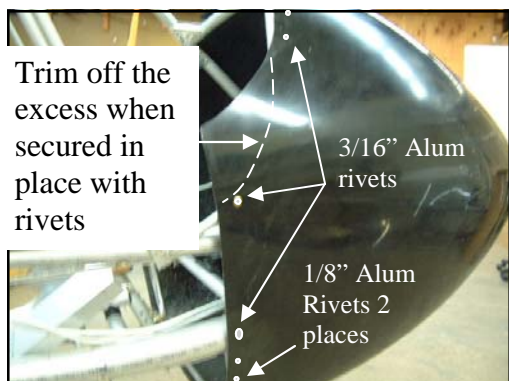

When you are satisfied with the position of the fiberglass nose, drill and rivet 3/16" alum rivets along FWF (3 places), the curved former on cockpit side rail (1 place), then on longerons (1 place). Drill and rivet 2 places for 1/8" rivets on stringer ribs and 3 places on the bottom into the 20" angled gusset (use 1/4" long rivets).

NOTE: If you intend to make your nose cone removable, use 3/16" screw bolts and nyloc nuts instead of 3/16" rivets.

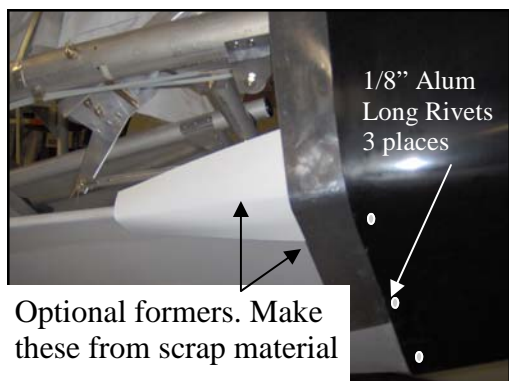

For a smoother transition from nose cone to fabric covering, you may want to manufacture some formers out of any scrap sheeting you may have. This picture shows an example of what can be done.

Once the nose cone is secured, determine if you need to trim the nose cone to follow the curved former tube at the front of the cockpit side rail (as shown above).



The next step is to sand the nose cone ready for gluing fabric to the edges and painting. Apply 100% Poly-Tak to at least 3" in from the edge of the nose cone and apply fabric in the same manner as you have already done on the wings etc. A 3" overlap is good. You can opt for a more professional looking finish by applying 2" finishing tape over the edge of your fabric on the nose cone.

How to cover the fuselage

Each piece of fabric is labeled for identification at the factory.

Start with the bottom fuselage fabric.

Use your skills and knowledge acquired covering your tail and wing section. Cover the bottom of the fuselage around the stringer section (1/2" x .035 tubing) all the way from front to rear. Finishing off at the inboard tail post. Be sure to wrap around the tubing and longerons far enough that the edges of the fabric won't show through the material after final completion. Shrink the bottom fabric at this point. Care must be taken not to 'Over shrink' as this will cause the bottom stringer assembly to 'bow' between the stringer ribs.

Next, find the rear fuselage fabric.

You will have two identical pieces here, use one for the left rear and one for the right rear of the fuselage. These fabric sections are oversized and will require trimming. If you are careful enough, you will end up with some generous pieces of fabric for possible future use in minor repairs or patching etc.

The use of spring clamps will be of tremendous help here.. You can either use a blade or pinked shears to trim the fabric. If you use a blade, you may want to tidy up the overlap with some 2" pinked tape after the shrink process. Try for a 2" or 3" overlap on the bottom fabric.

Be sure to carefully consider how to cut and trim for the Gear Weldment area. We have found that making a 'collar' from spare fabric works well for tidying up around the gear leg Weldment area. Be sure to 'pre-shrink' the collar before applying it over the Weldment. If you shrink it after it has been applied with Poly-Brush, you will find that it will pull and separate from the underlying fabric.

Locate front fuselage fabric.

There are two identical pieces here for each side of the fuselage also.

There is an overlap area between front and rear pieces of fabric. It is advisable to have at least a 3" overlap cemented with Poly-Tac. Care must be taken when shrinking the fabric so that the join does not separate.

Once all pieces of fabric are in place and shrunk, then you can apply the fabric sealant.

NOTE: The following pictures show the covering procedure WITHOUT the nose cone attached. Our customer opted to install a 'removable' nose cone.



Bottom fabric glued to the bottom stringer assy.
Do not 'over shrink' as bowing of stringer may occur

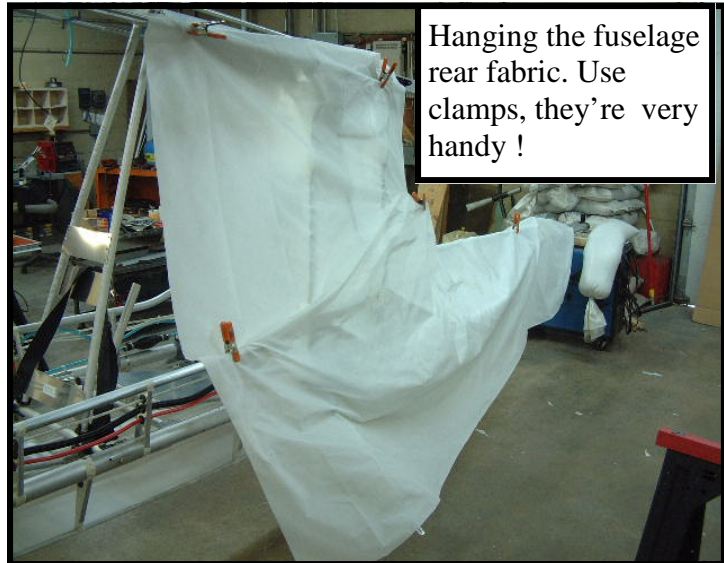

Hanging the fuselage rear fabric. Use clamps, they're very handy !



Your surgical skills will be needed here..



Some creative trimming will be needed here..

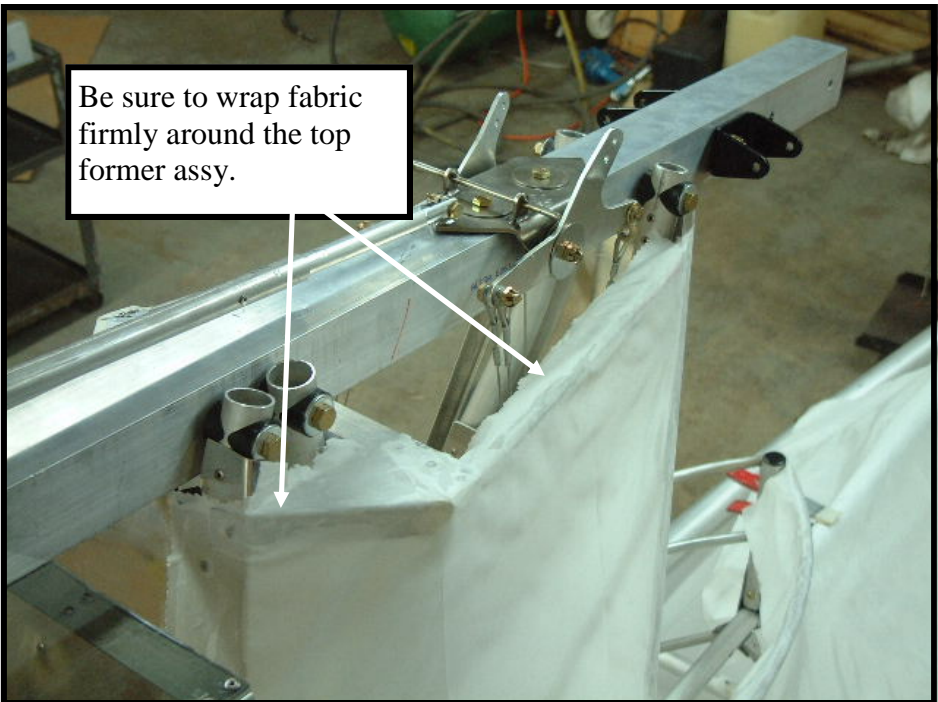

Be sure to wrap fabric firmly around the top former assy.



Hanging the fuselage front fabric.

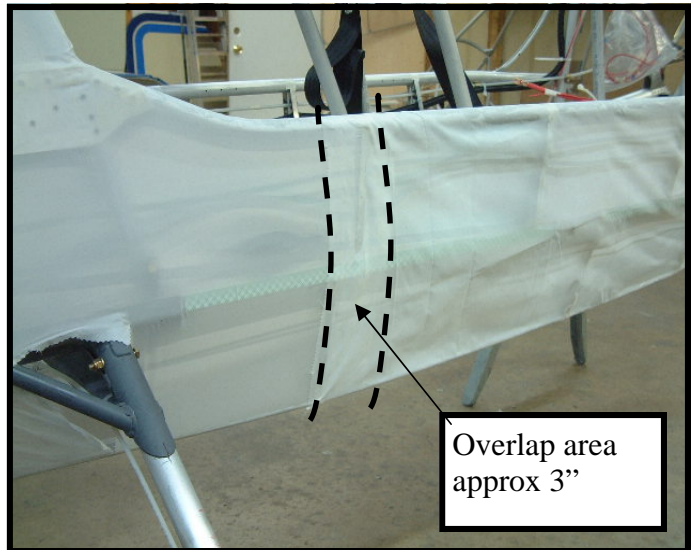

Overlap area approx 3"



A neat job of covering



Fabric shrunk and sealed. Ready for paint.

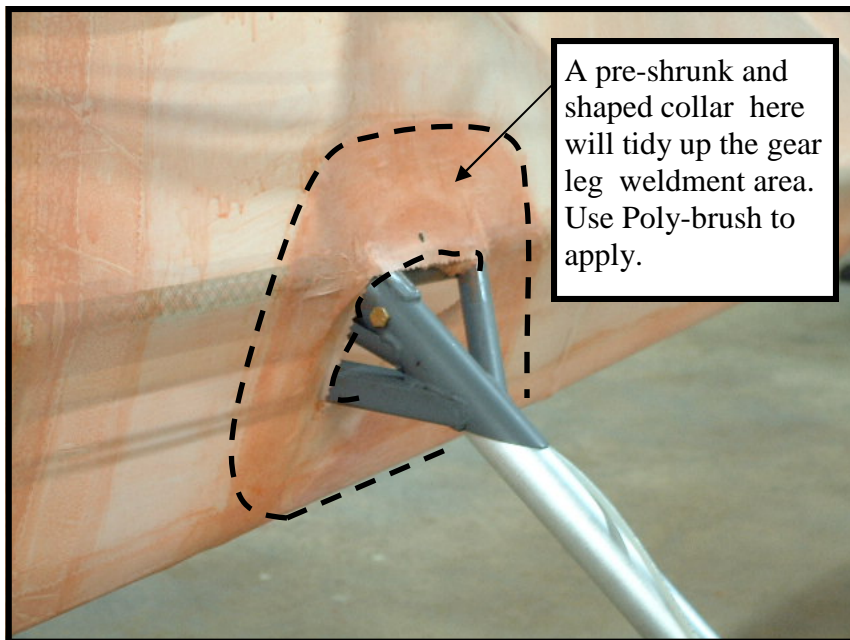

A pre-shrunk and shaped collar here will tidy up the gear leg weldment area. Use Poly-brush to apply.

How to attach the throttle inter connect assy.



Rear Throttle quadrant assy.

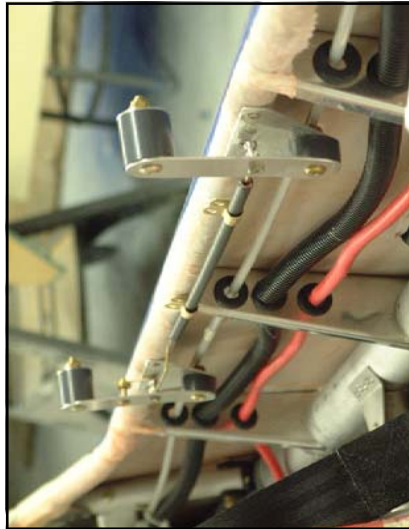

Example of throttle interconnect setup

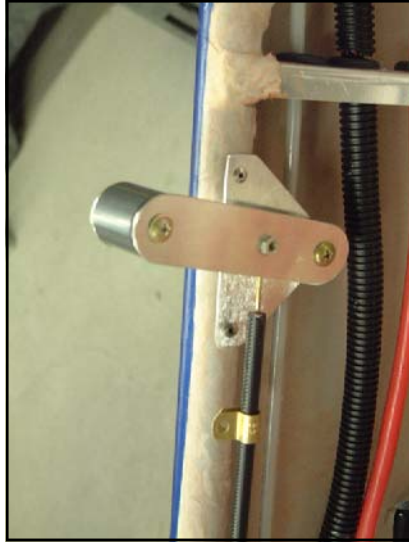

Front throttle quadrant assy.

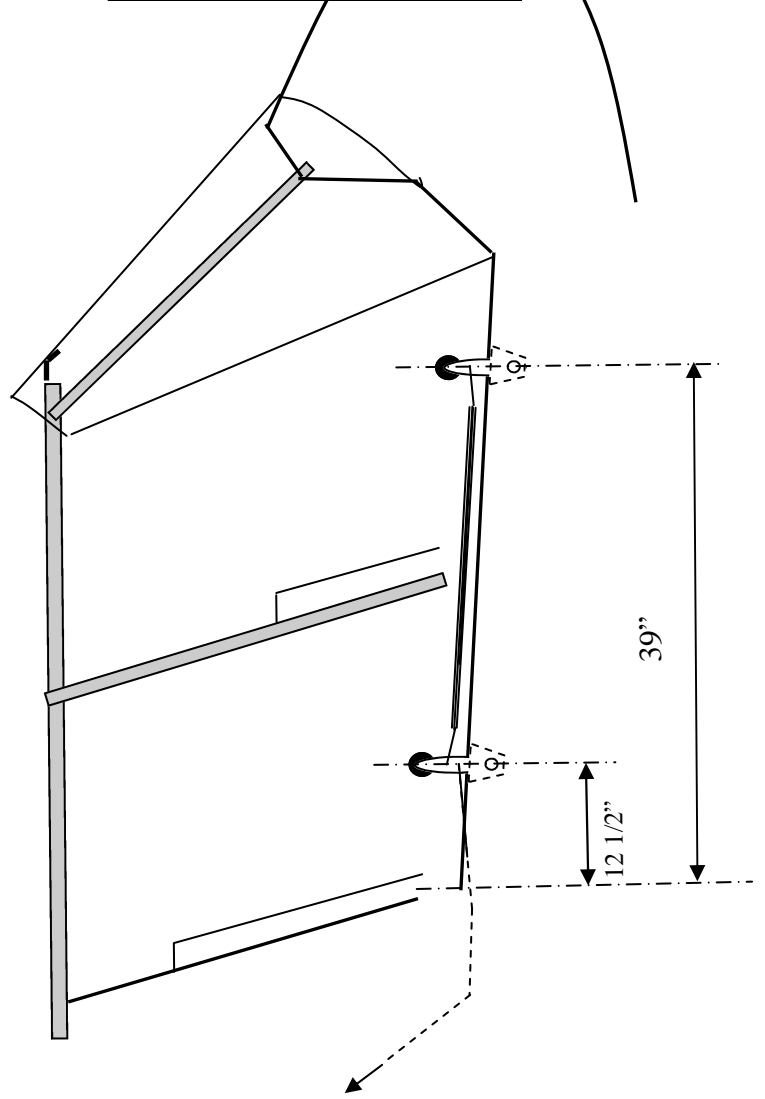

Throttle cable to Engine

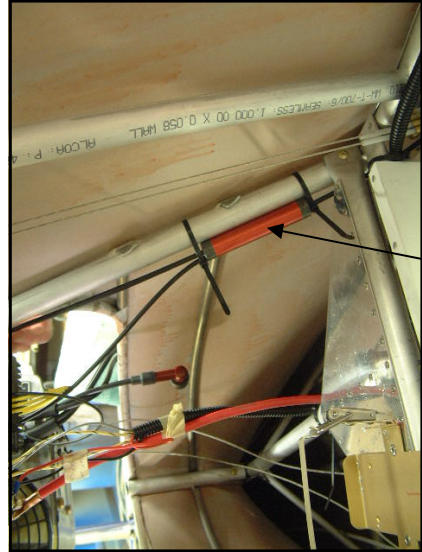

We found that zip tying the cable splitter to the 2DT4 at this point works well.

How to attach the Choke cables.

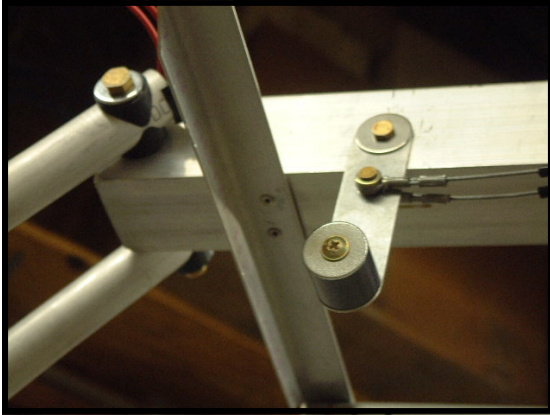

Position the throttle lever approx 5" from front of Root tube and 1 1/4" up from the base of root tube. Drill a 3/16" hole through the 2" square root tube. Secure choke lever in place with 1 x AN3-24, 1 x AN365-1032 Nyloc nut, 1 x AN960-10 washer and 3 x large area Zinc washers

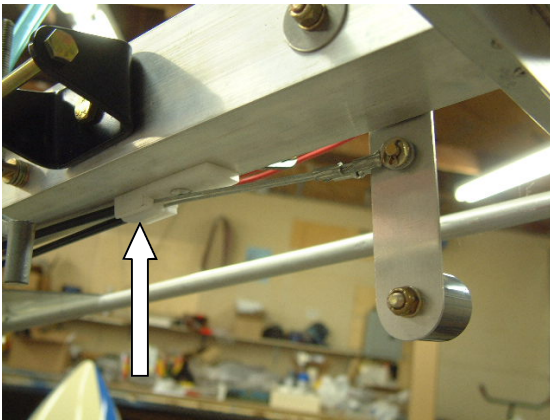

Attach the double choke cable to the choke lever using accompanying hardware. Secure the outer sleeves to the underside of the root tube with AD4 Adel clamps, or if you have any scrap nylon block, fashion a cable stop system as we have done here

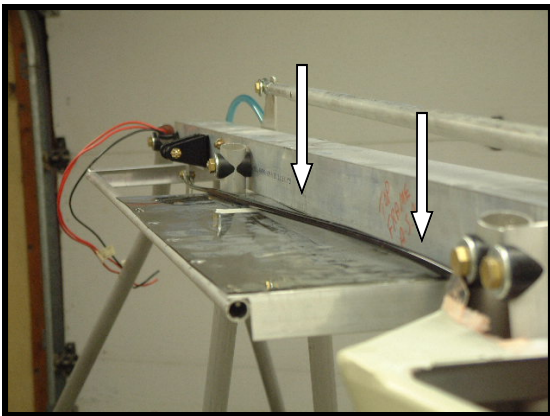

Run the cable and outer sleeves along the top of the door frame. It is a good idea to secure it in a couple of places using AD4 Adel clamps.

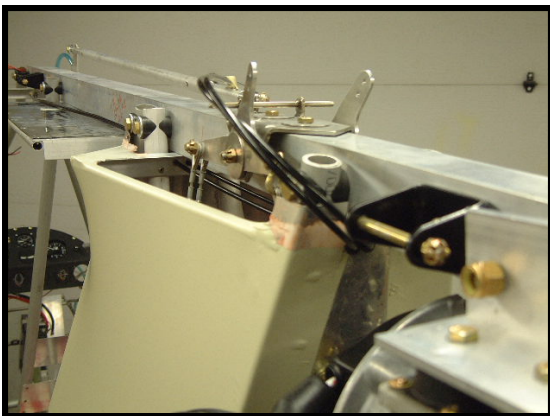

Carefully weave the cables through or over the front and rear fuselage former gussets. Some protection from chaffing may need to be added around the cables if choosing to go through the FFF2 and FFR2. Tie the cables back and away from the engine until ready to install. You will find the cables are even in length and this will cause the cable for the front carburetor to bow a little more than the rear cable.

How to make gear leg fairing inserts

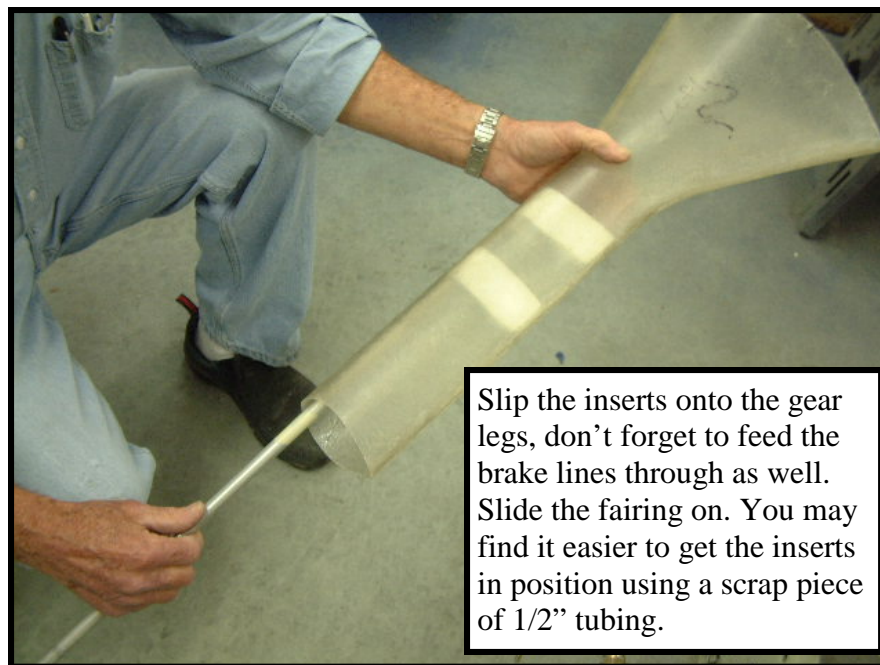
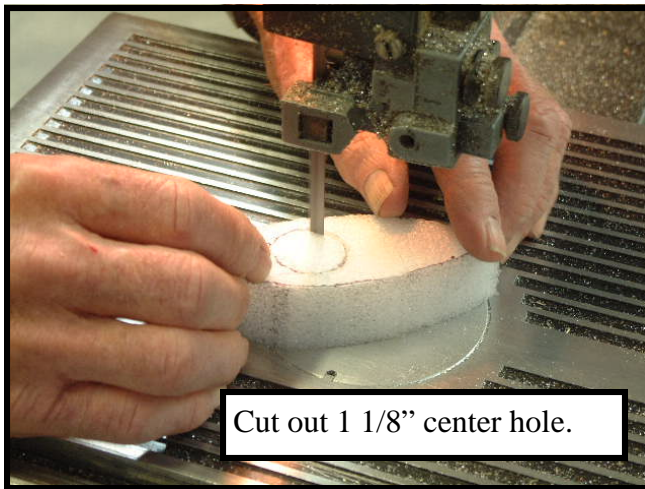
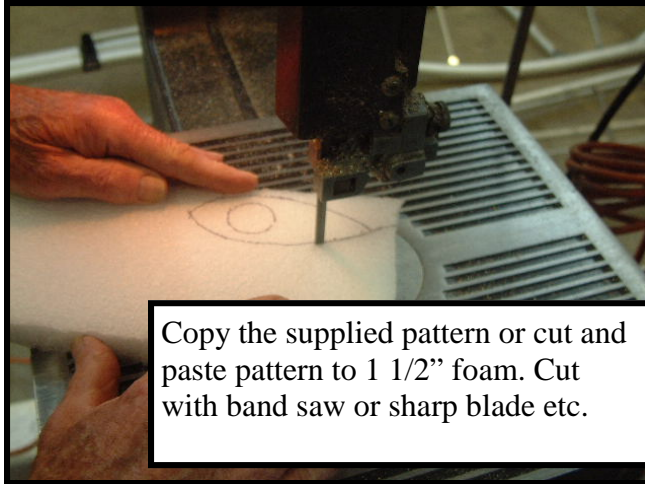

Cut and paste the templates
onto the 1 1/2" foam provided
and follow cutting instructions

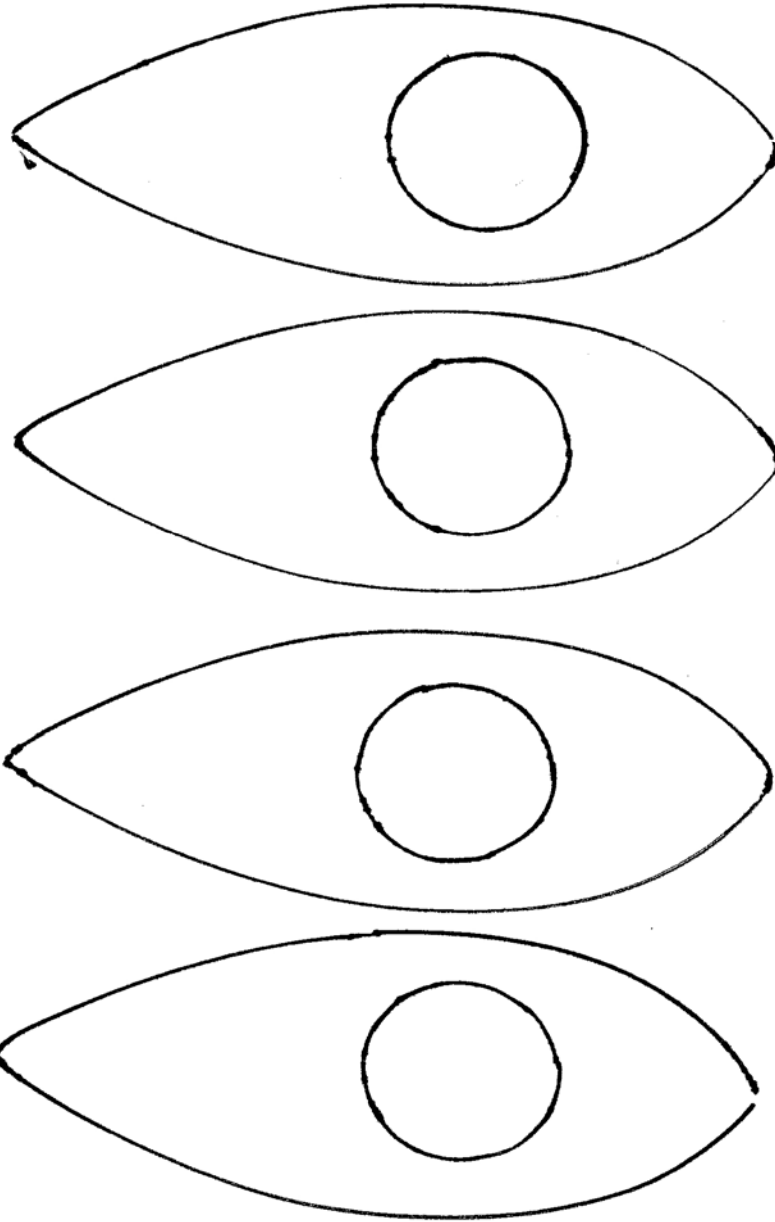

How to install gear legs and gear leg fairings

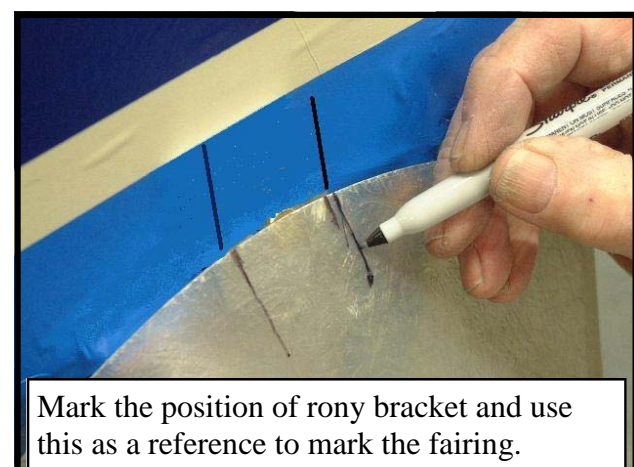
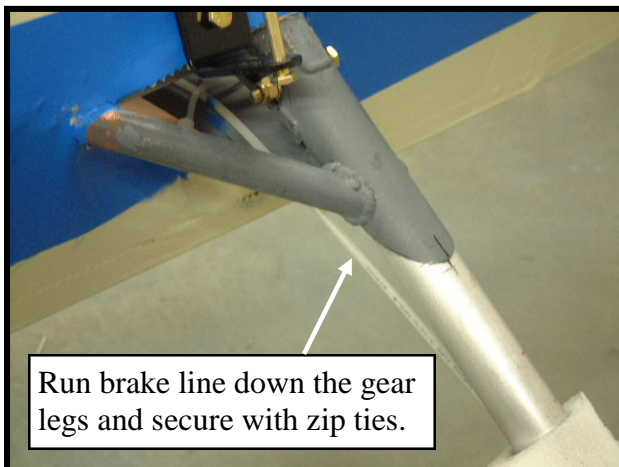
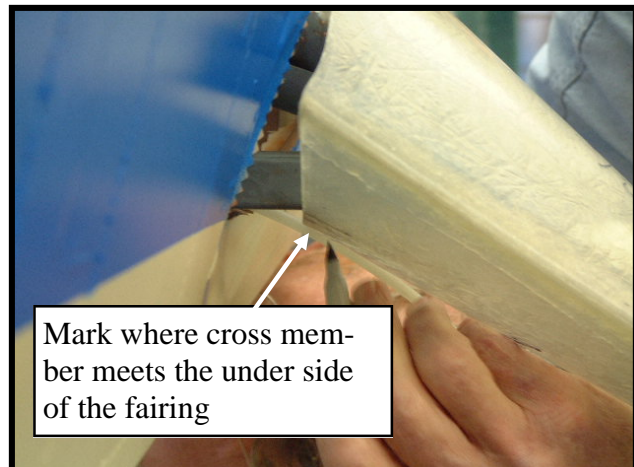
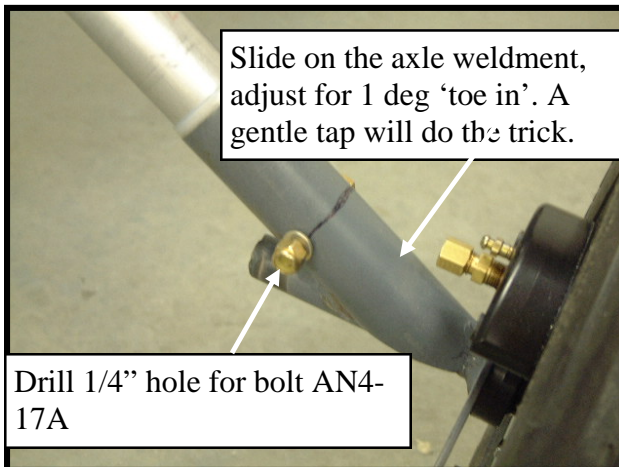
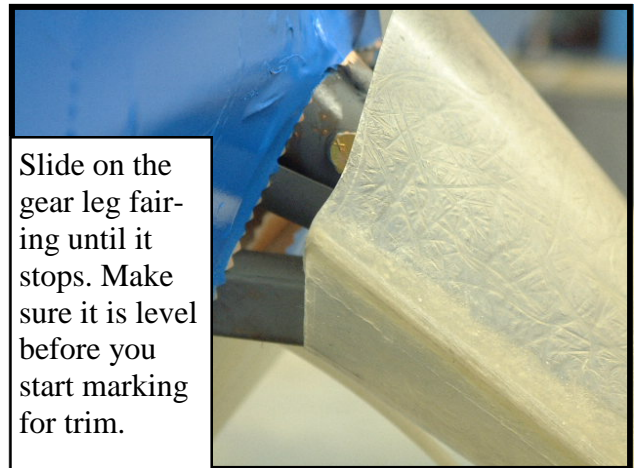
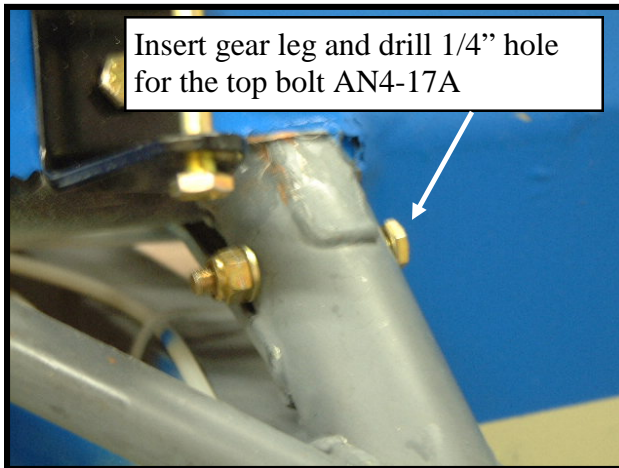

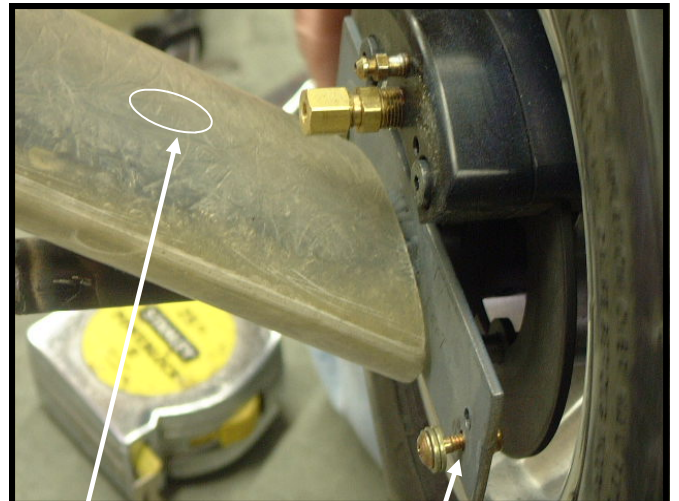
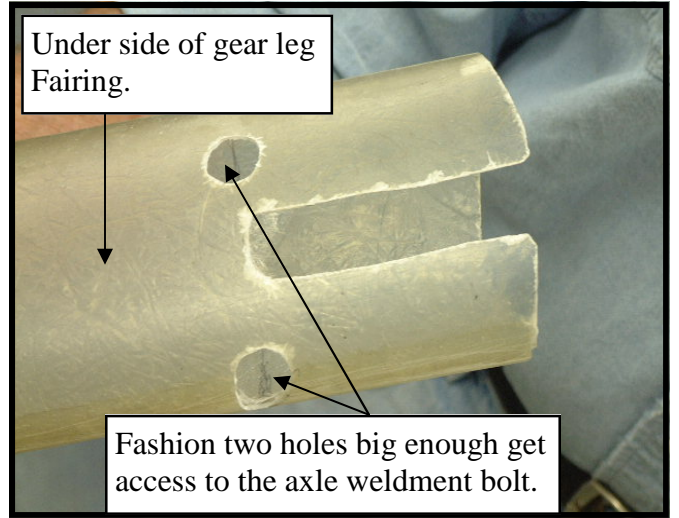
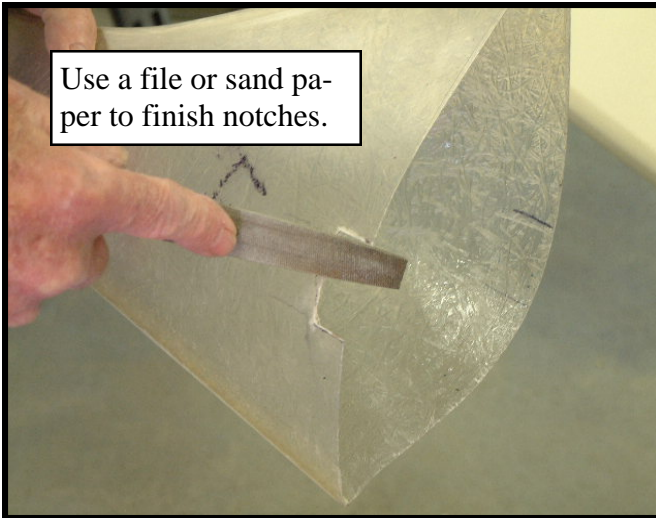
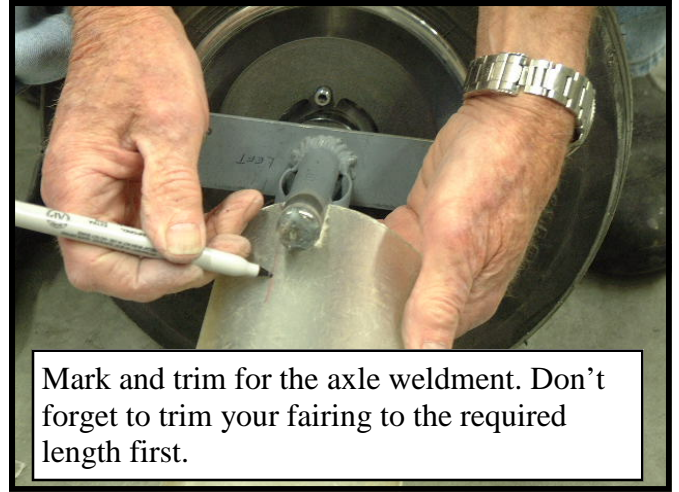
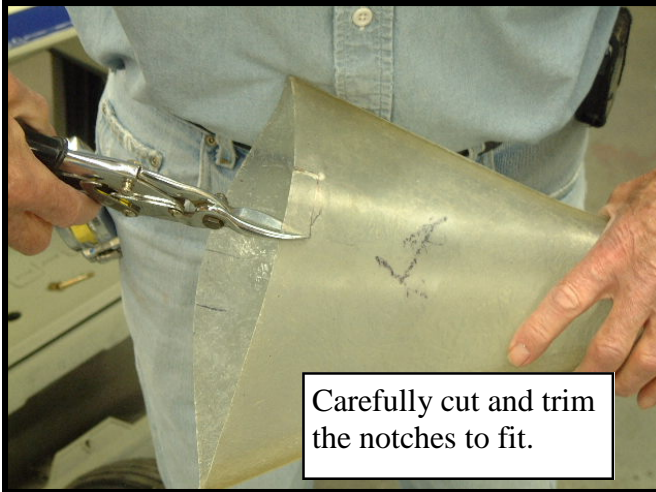

Print our or copy this page

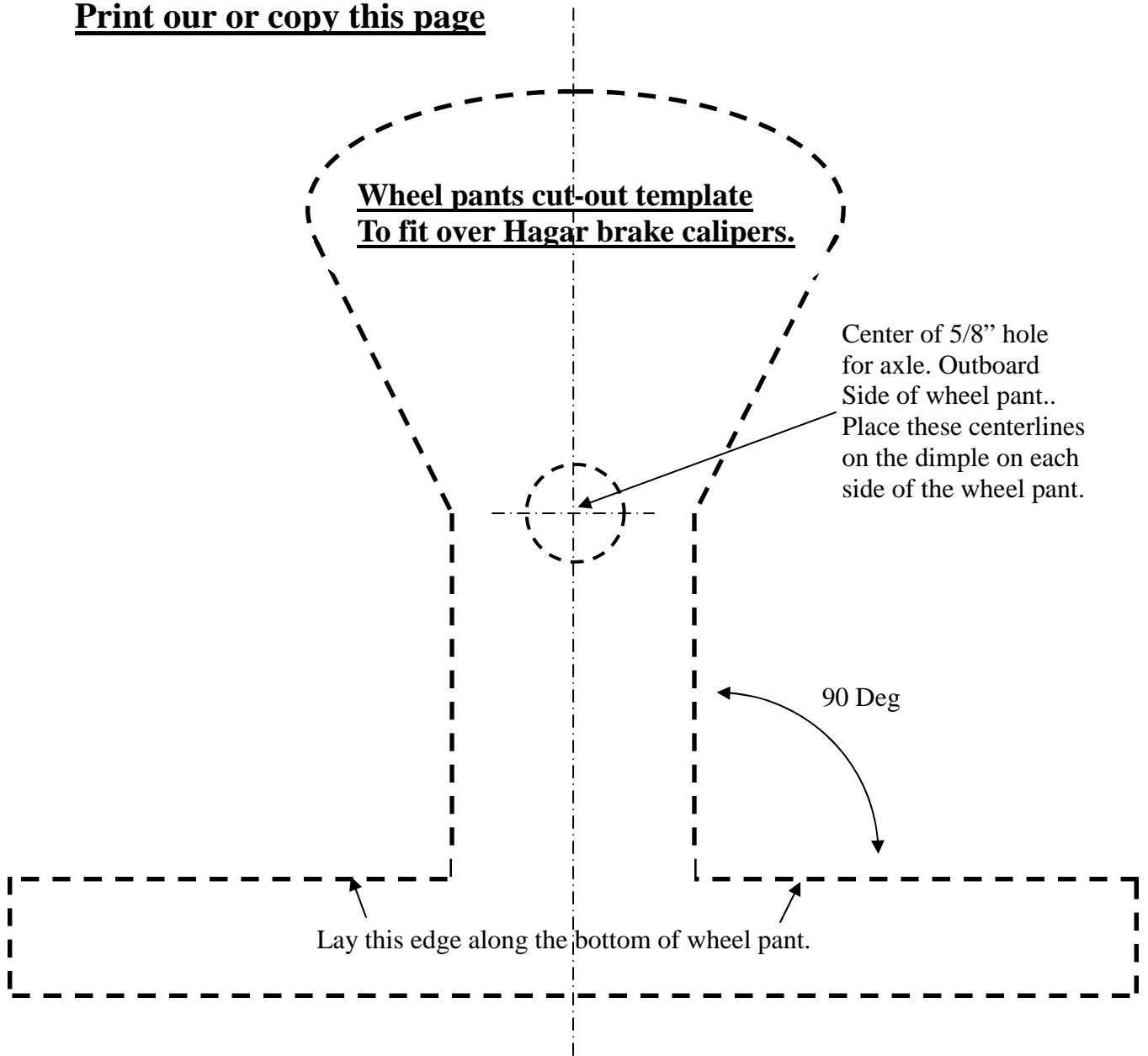

Cut this template and lay it upon the wheel pant. Trace around it and cut out. Some filing/trimming may be required.

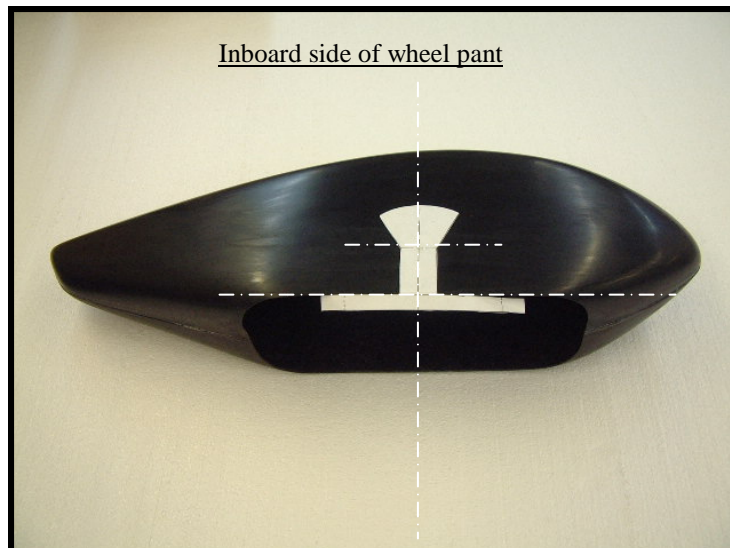

Wheel pants installation

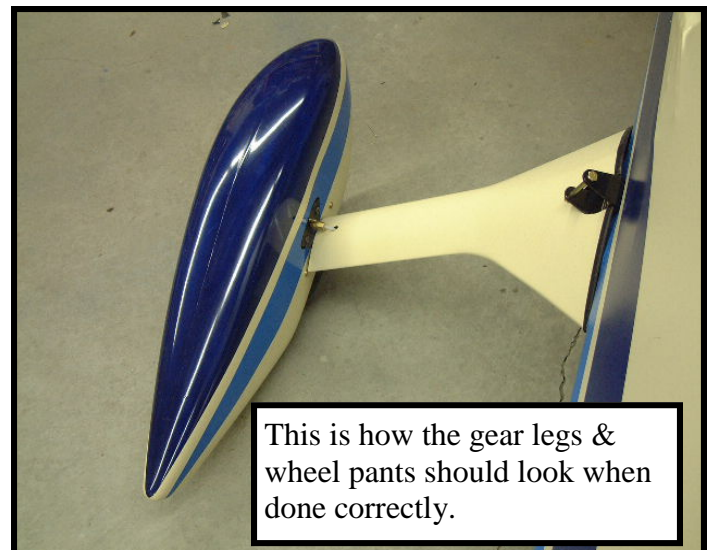
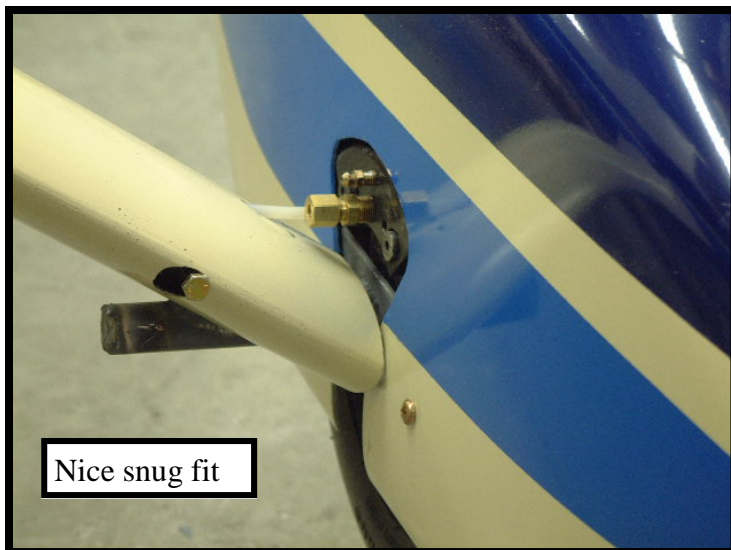
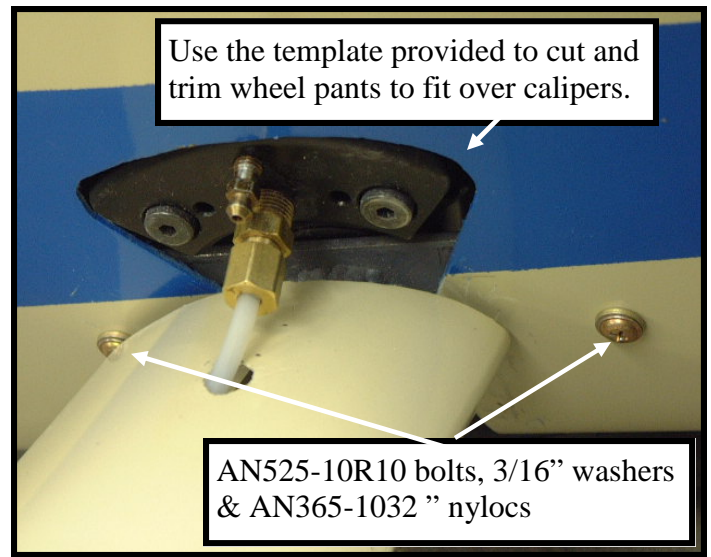
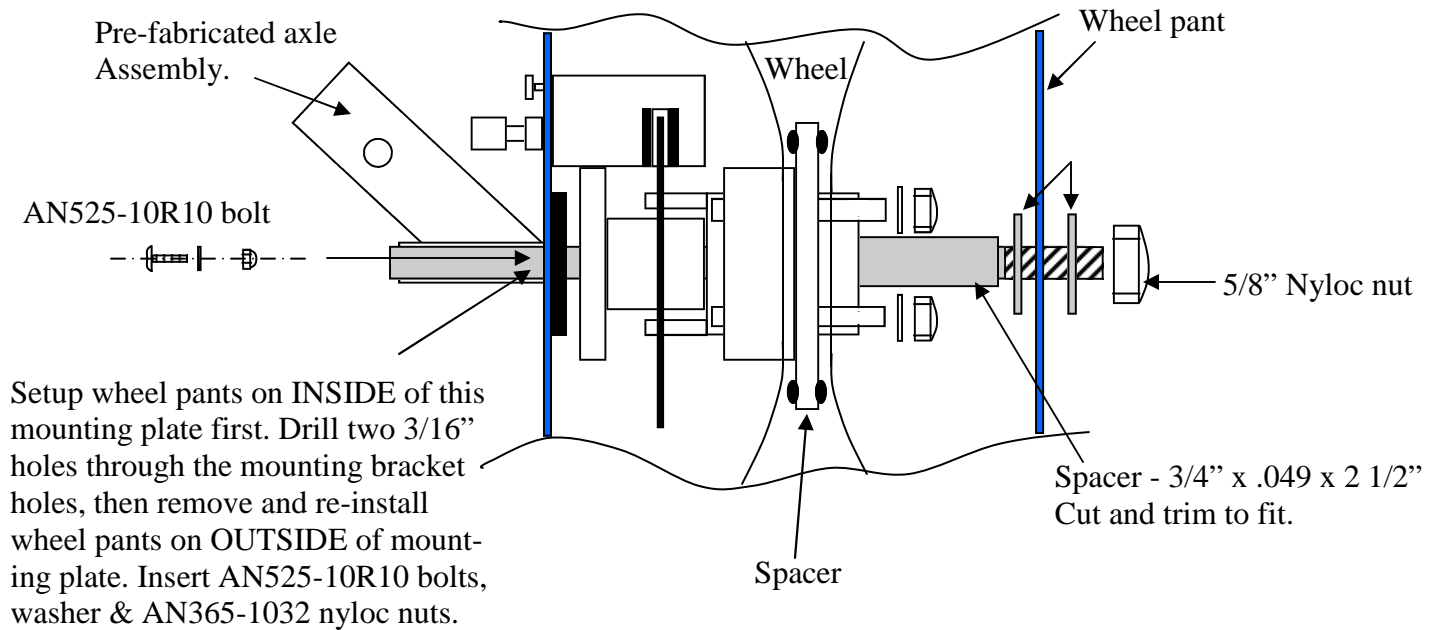

Challenger nose gear assembly NG-100 (Less fork)

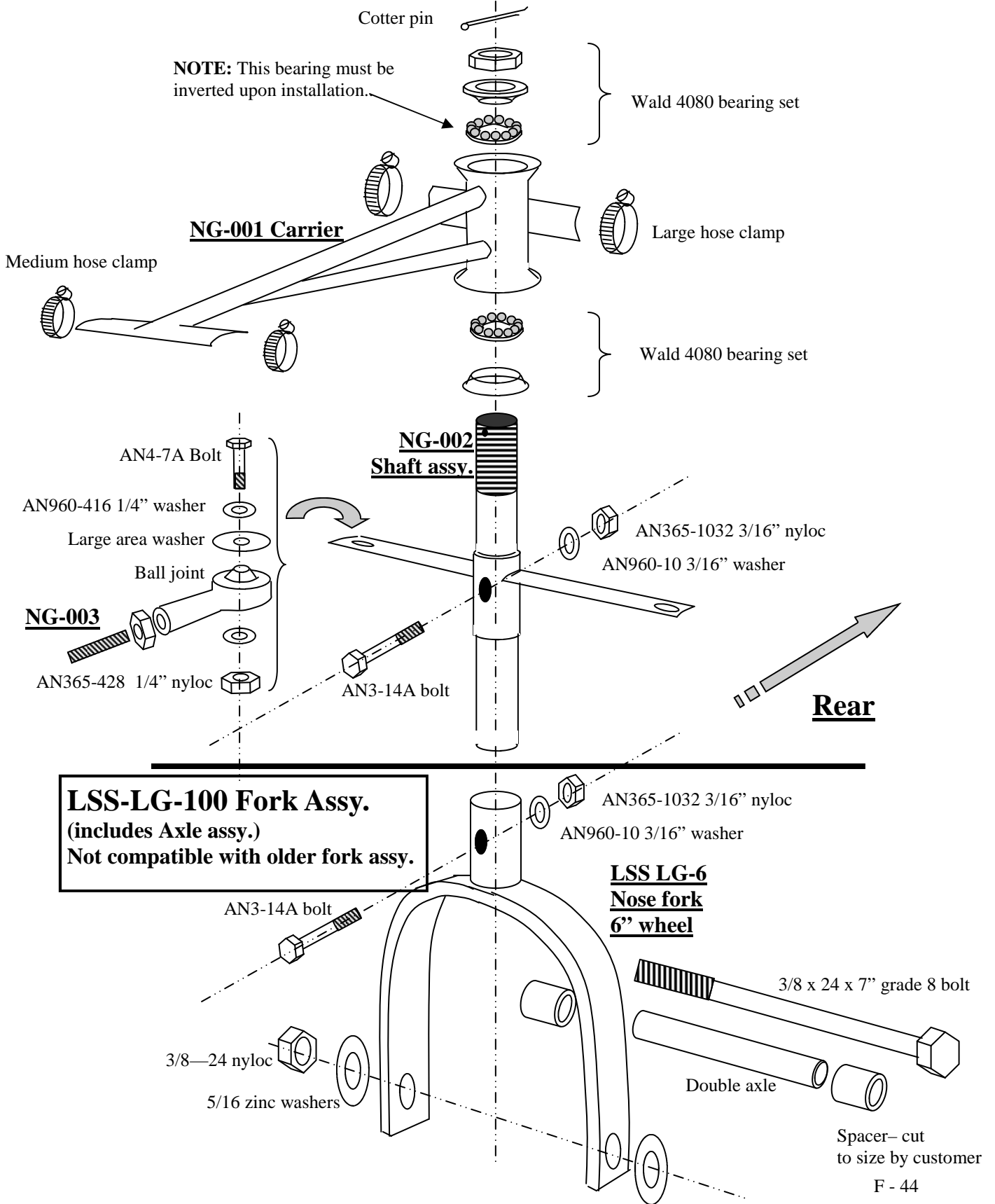

Nose gear carrier and wheel installation.

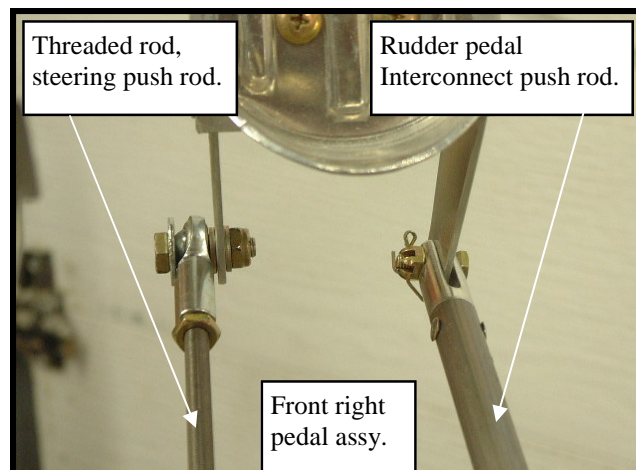
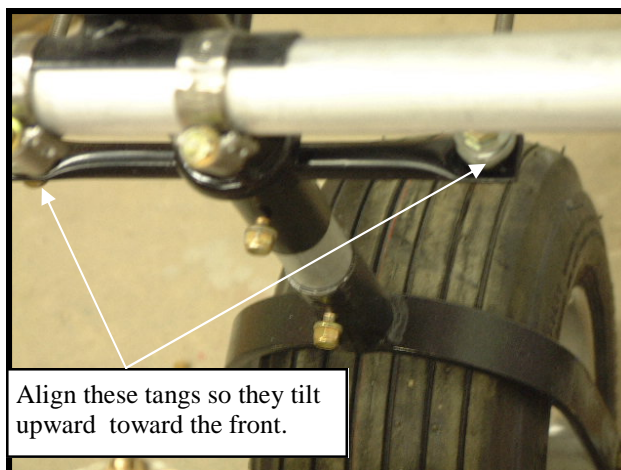
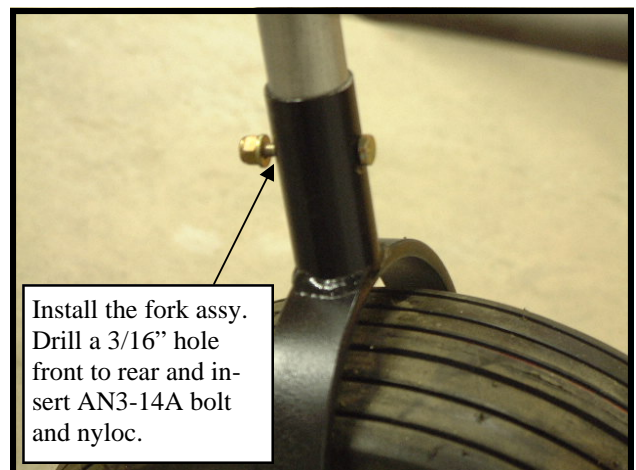
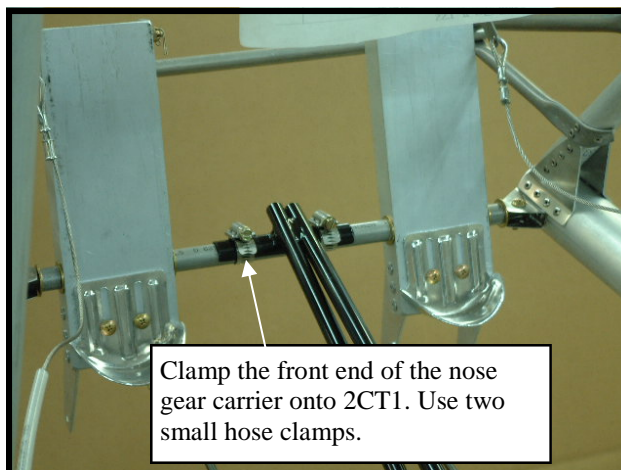
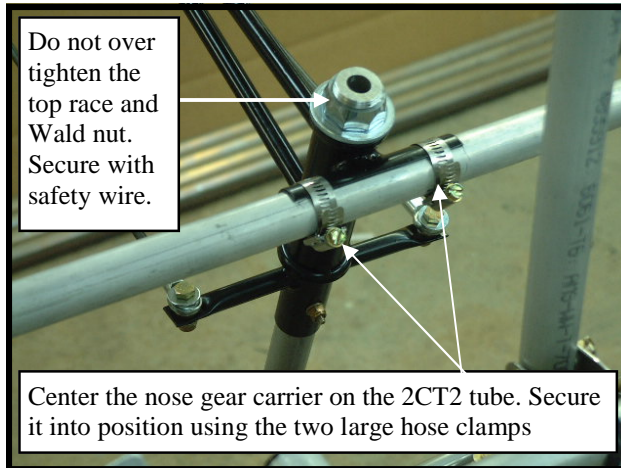

Nose gear wheel pant installation

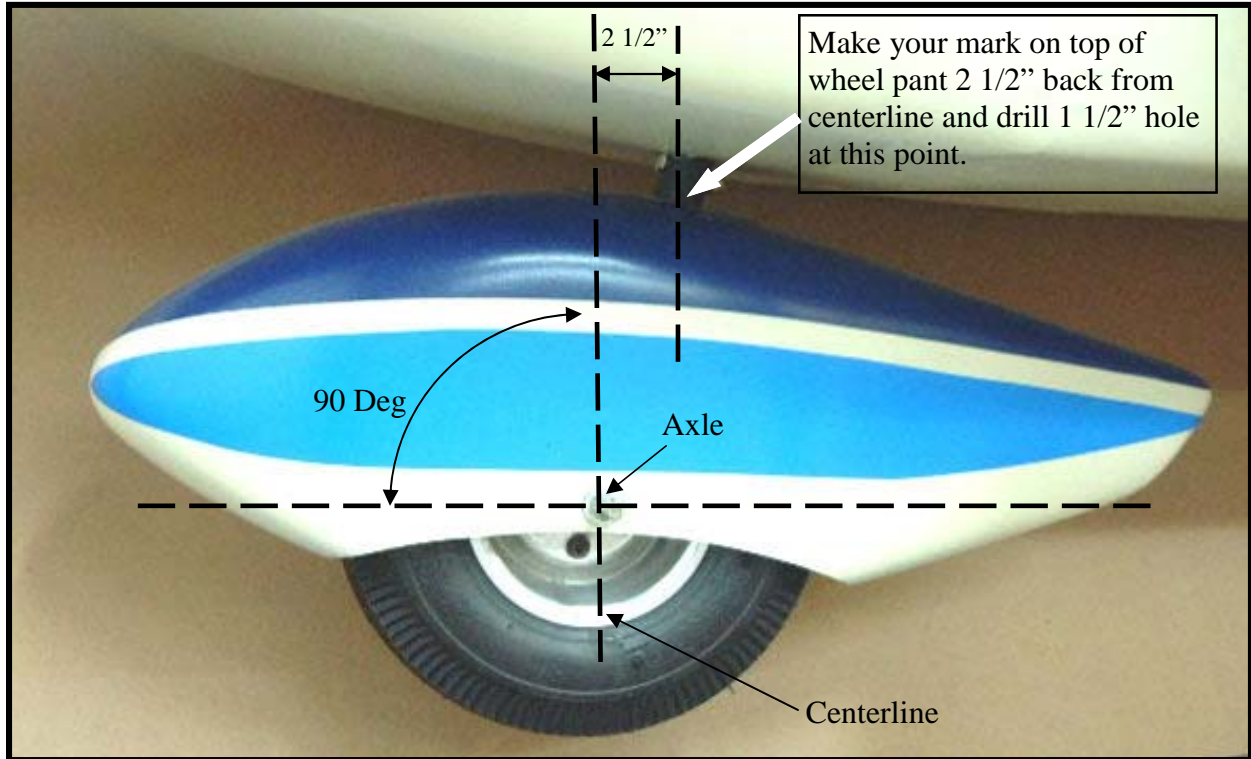

Sectional view of front wheel assembly

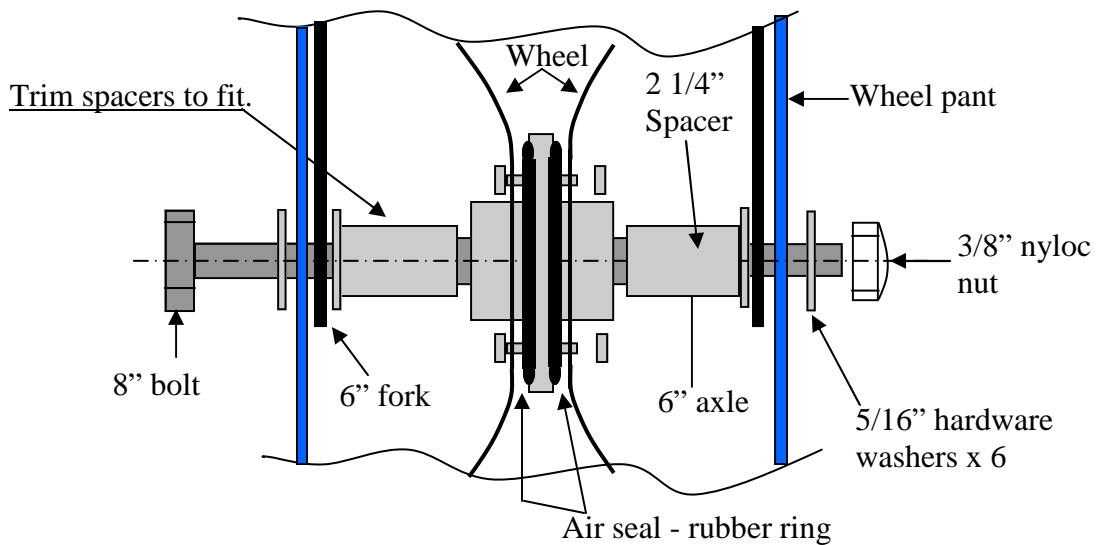

Drawing not to scale

How to install the tail section and dorsal fin

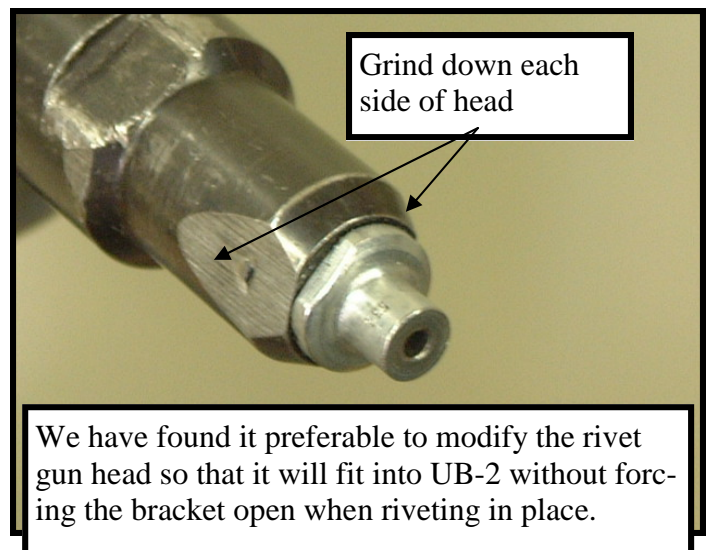
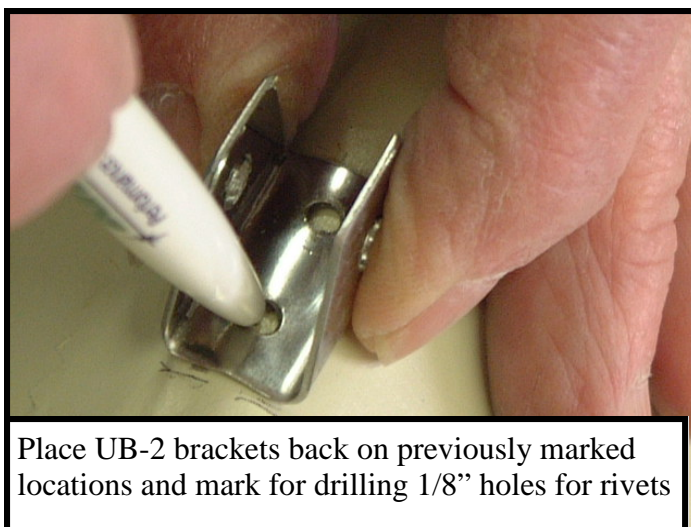
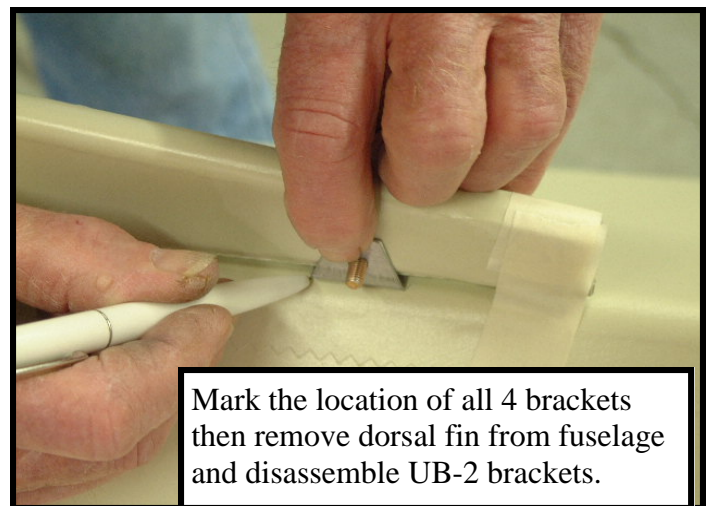
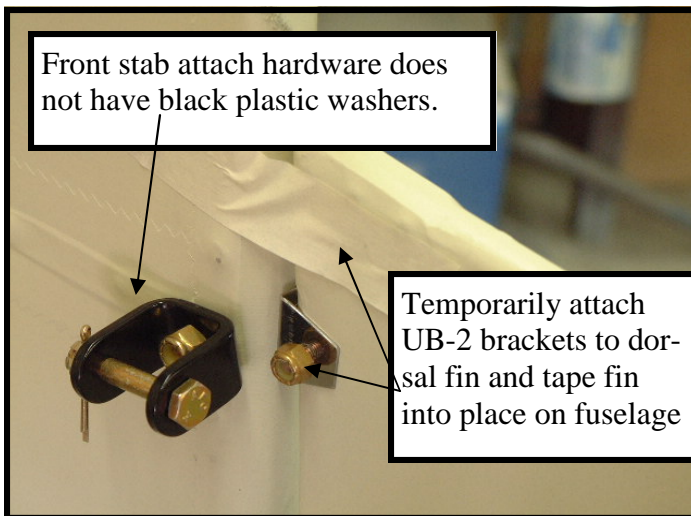
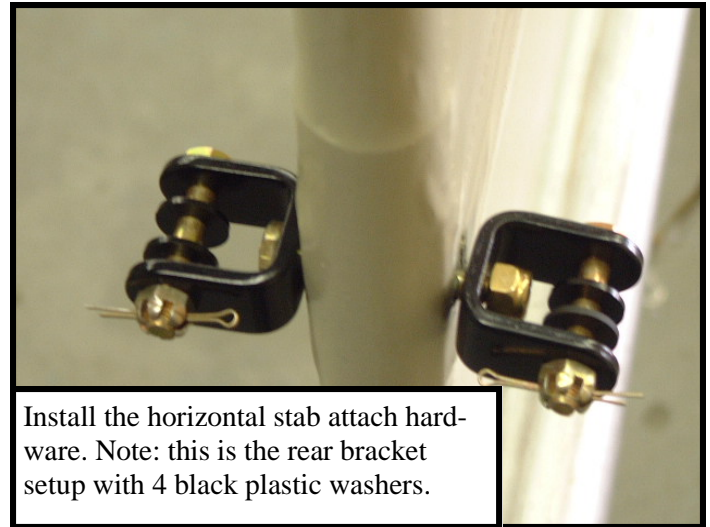
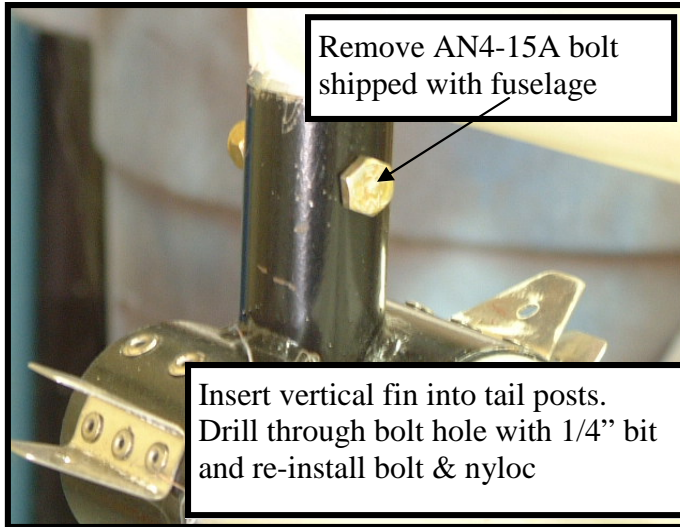

How to install the tail section and dorsal fin



Drill 1/8" holes for stainless steel rivets (short).



Pop the rivets using the modified rivet gun.



Attach horizontal stab to hardware and use masking tape to hold stab in place.

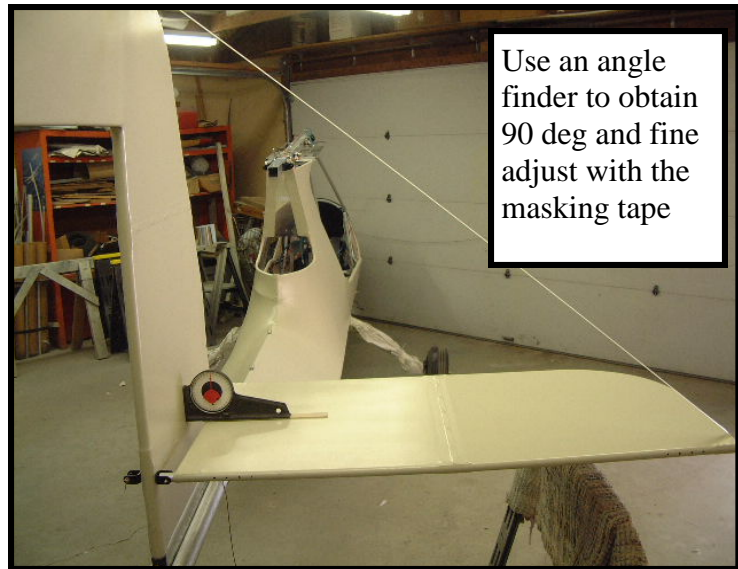

Use an angle finder to obtain 90 deg and fine adjust with the masking tape

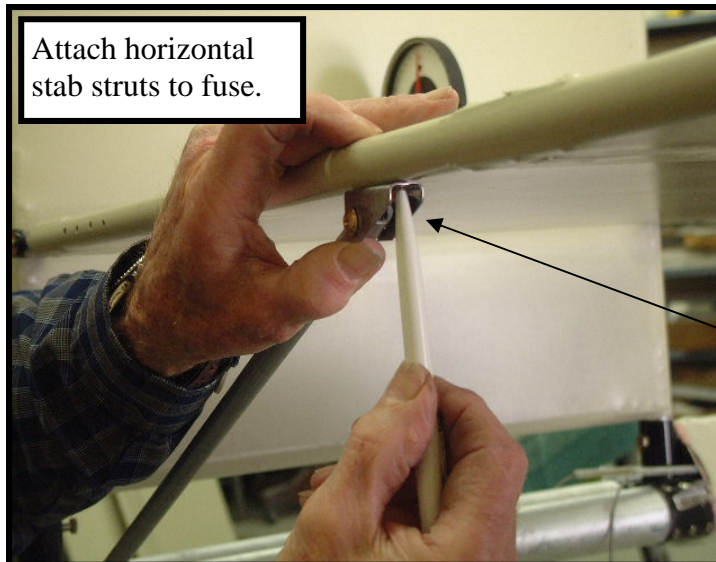

Attach horizontal stab struts to fuse.

Attach UB-3 to end of stab struts and mark location for drilling and riveting. Be sure to install UB-3 with angle pointing outward.

Locate the factory drilled holes for rudder horns. Burn the holes through with a soldering iron and assemble both rudder horns with AN365-10R20 bolts and 3/16" nyloc nuts

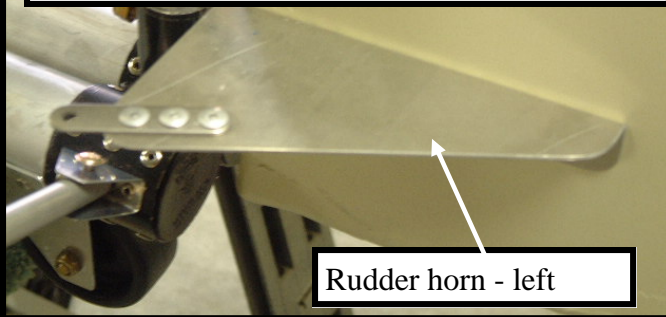

Elevator pushrod and ball joint assembly

Elevator horn - Left

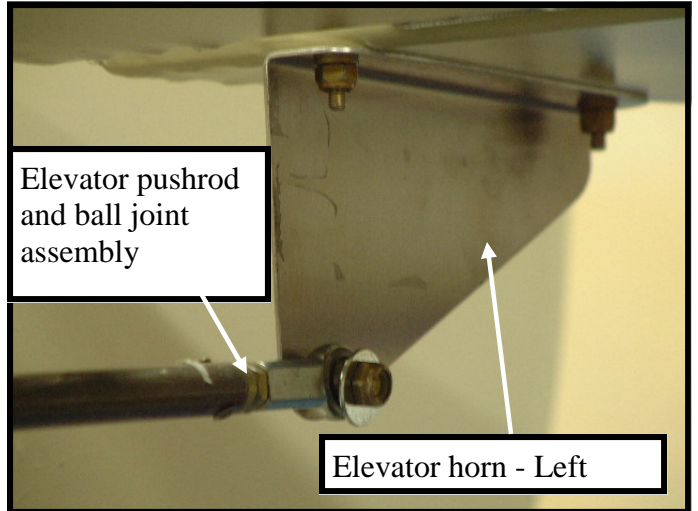

Rudder horn - Right

Note the correct orientation for the rudder horns. There is no torque value for these bolts, just tighten until snug.

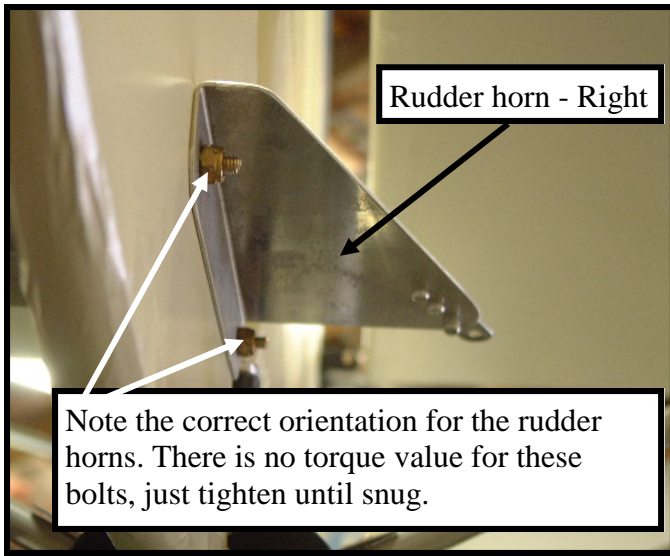

L & R elevator push rods and bell crank assy. Note. Large washer on outboard side of ball joint assy.

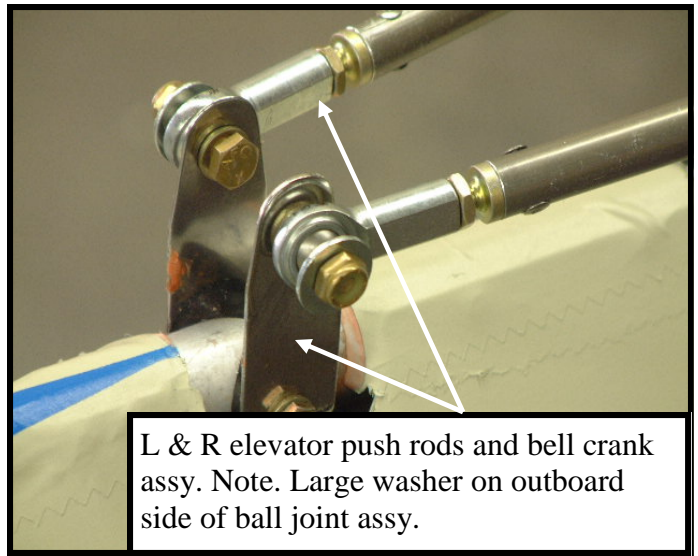

First step to install elevator push rods is to clamp the elevator in place using a long and straight object. Careful not to scuff the paint

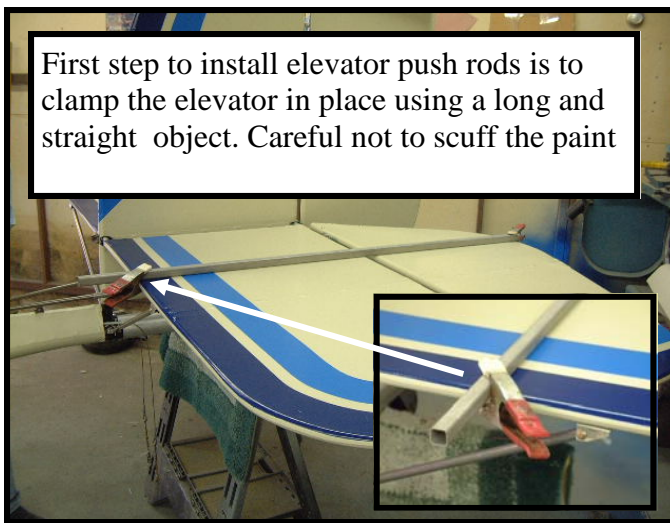

The elevator should be approx 30 deg up and 25 deg down deflection. Fine tune using the ball joints

Rudder Assy.



Attach the Rudder to the vertical stabilizer. Use 2 x AN3-5 bolts, AN310-3 castle nuts and AN380-2-4 cotter pins

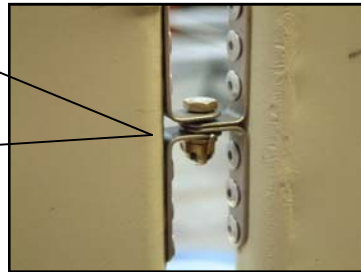

Attach the rudder control cable to the rudder horn with AN3-5, AN310-3 castle nut, two AN960-10 washers and an AN380-2-4 cotter pin. Safety wire the turnbuckle after setup.

How to install the Rudder stop assembly.

4 x AN525-10R14

5 x AN365-1032 Nyloc nuts

5 x AN960-10 3/16" washers

2 x PVC blocks (3" x 1/2" x 3/4") Trim to fit.

2 x PVC segments (1" diameter x 1/2" thick - 3/16" hole drilled).

1 x AN3-24A bolt

Drill a 3/16" hole at 1 3/4" on the bottom tube of V-fin assembly. There will be a S/S rivet in a gusset at this point. This must be removed. Insert the AN3-24A bolt, two 1" PVC segments and a nyloc.

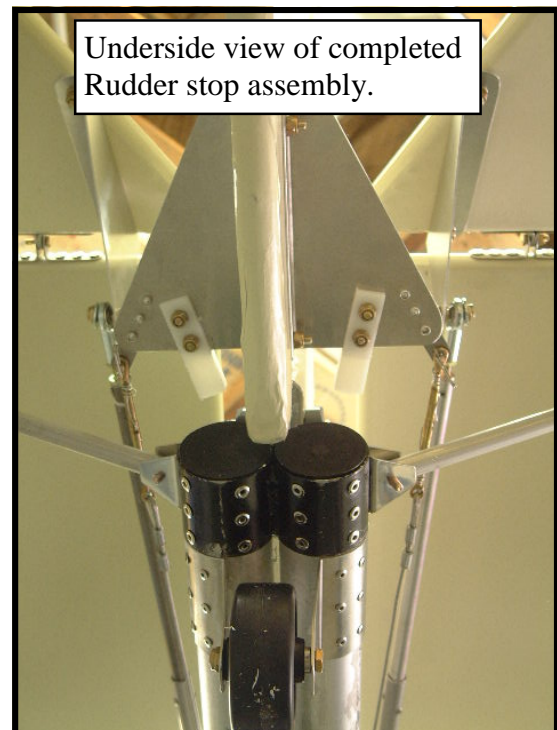
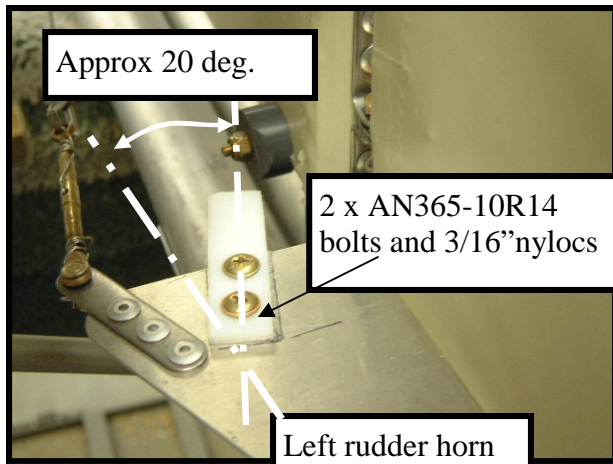
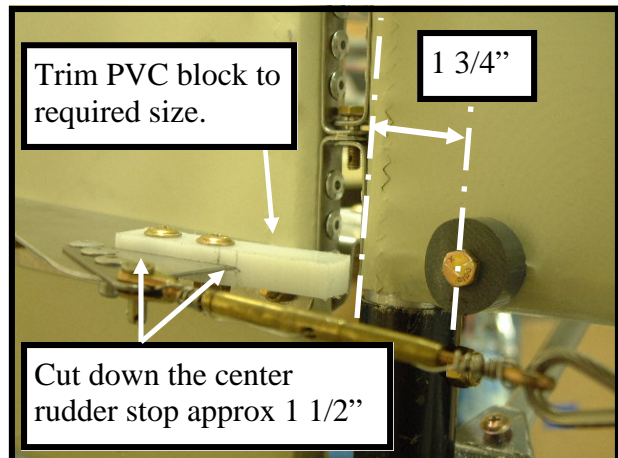
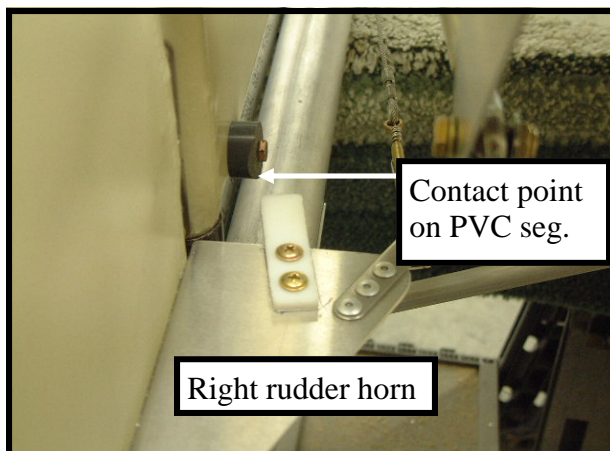

Rudder should stop approx 1" from Elevators (left and right). Adjust the PVC blocks to correct position before final attachment.

How to install the tail wheel

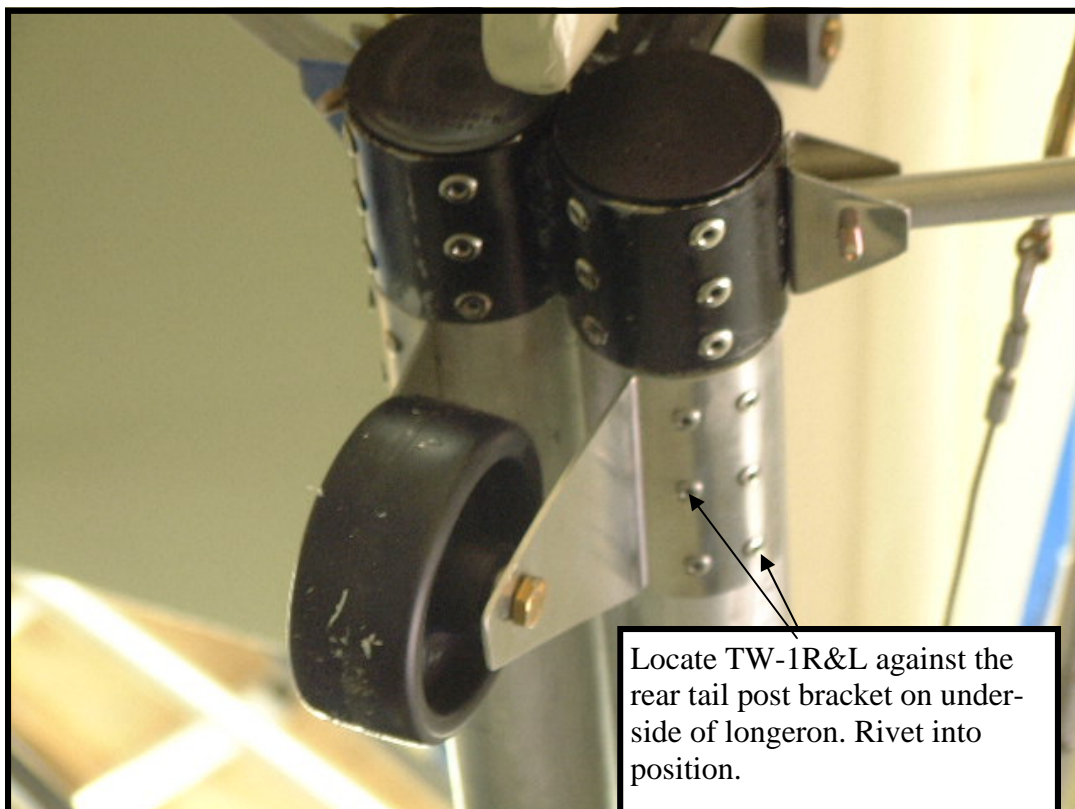
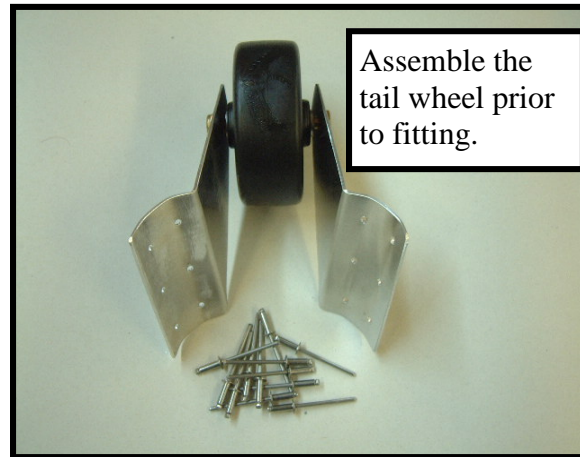
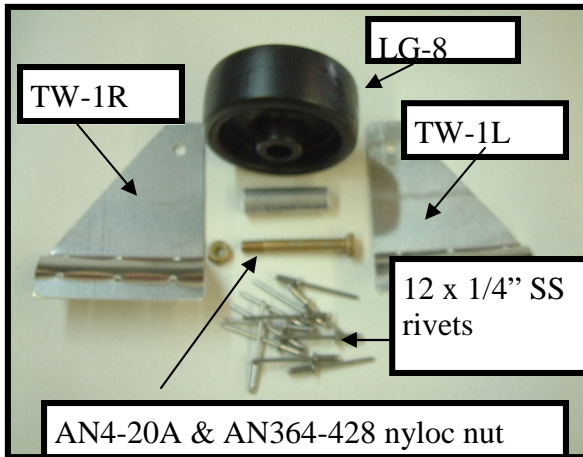

How to install the LSS-DFVFG (Dorsal fin - Vertical fin gusset)

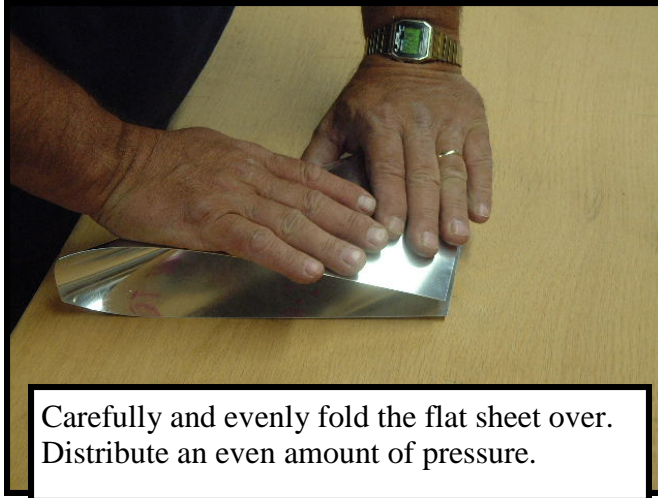

Carefully and evenly fold the flat sheet over. Distribute an even amount of pressure.

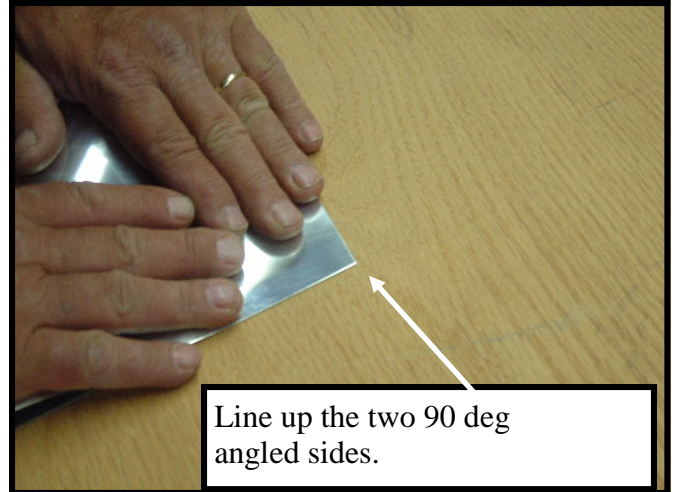

Line up the two 90 deg angled sides.

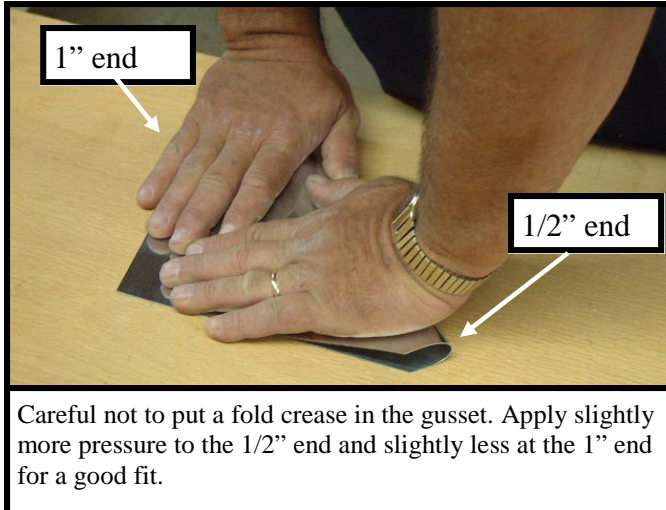

Careful not to put a fold crease in the gusset. Apply slightly more pressure to the 1/2" end and slightly less at the 1" end for a good fit.

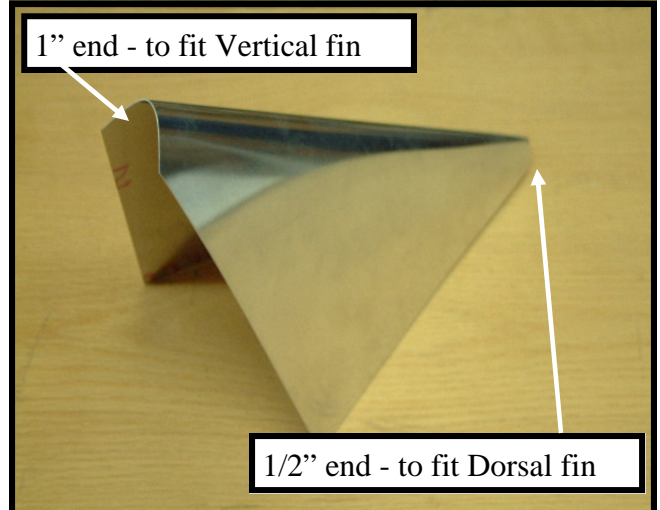

1/2" end - to fit Dorsal fin



Use spring clamps to Hold gusset in place. We have pre painted ours but that is not necessary.

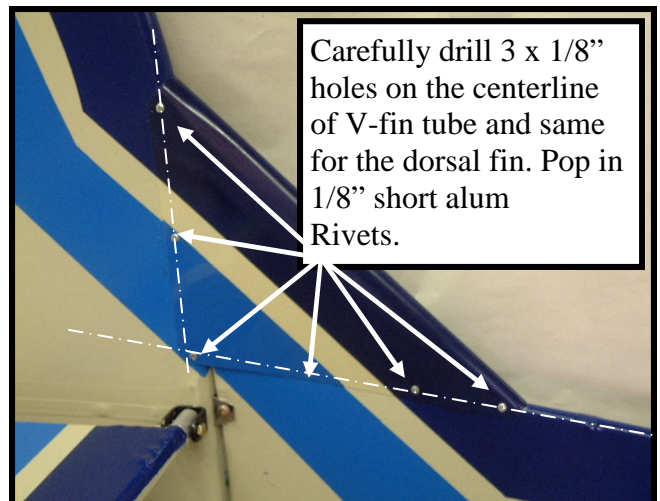

Carefully drill 3 x 1/8" holes on the centerline of V-fin tube and same for the dorsal fin. Pop in 1/8" short alum Rivets.

How to attach Wing Spars to the root tube.

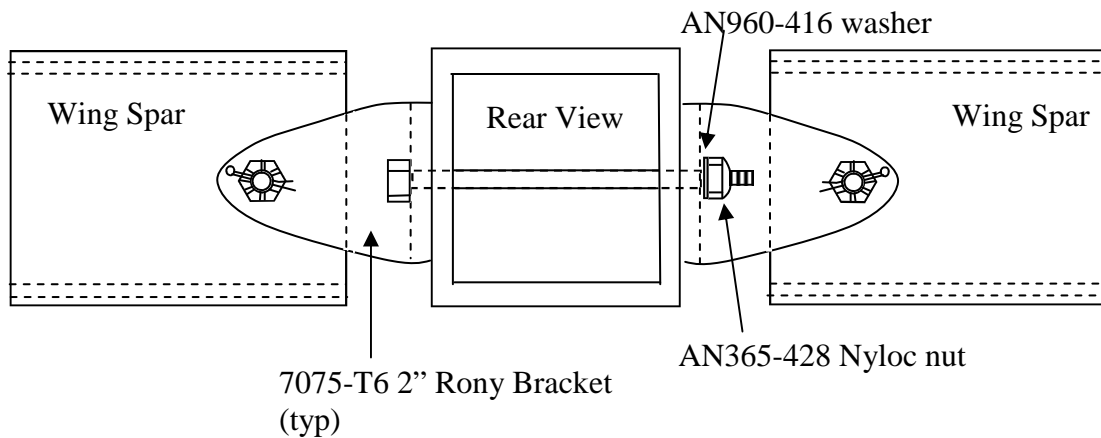
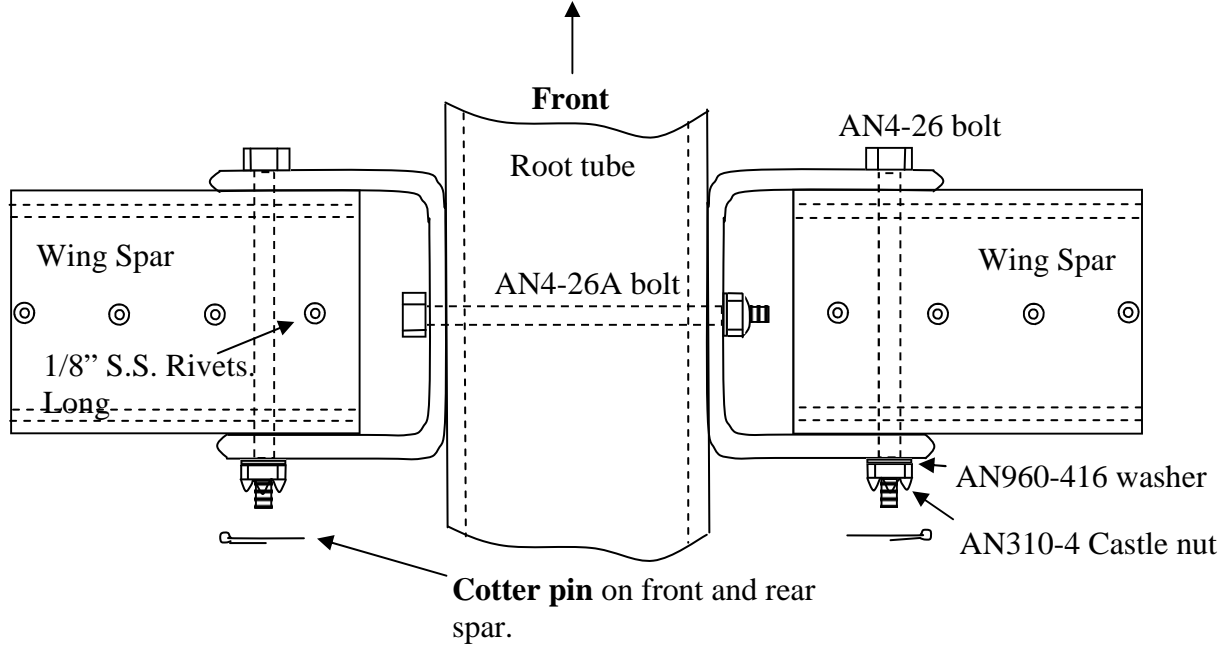

Install wing spar and strut attach brackets as per illustrations.

Do not over tighten bolts holding brackets to hollow tubes, but tighten only until snug.

Install wings into 2" Rony brackets (as shown above) and wing struts into 1-5/8" Rony brackets. These castle nuts need only be finger tight.

If your Challenger will be disassembled only once per year (for annual inspection), you can use an AN4-26A bolt & nyloc nuts instead of castle nuts and tighten until snug.

How to attach lift struts to fuselage

Do not over tighten bolts holding brackets to hollow tubes, but tighten only until snug.
 Install wing struts into 1-5/8" Rony brackets. These castle nuts need only be finger tight.
 If your Challenger will be disassembled only once per year (for annual inspection), you can use a AN4-22A & nyloc nuts instead of castle nuts and tighten until snug.

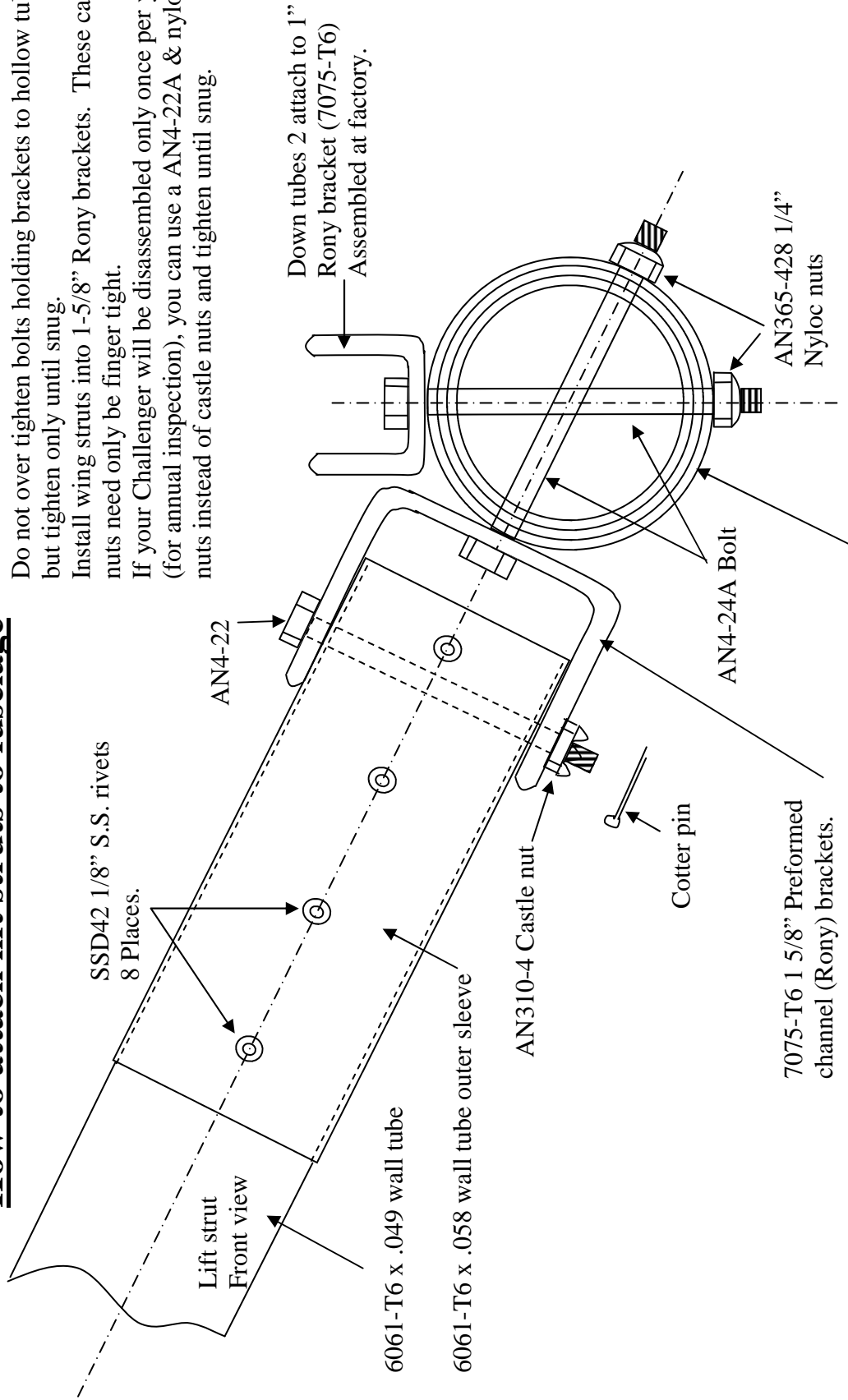

Triple wall, sleeved longeron section
 (static tested to 2,000lb.) Total wall
 Thickness = 3/16"

**ALL BOLTS MUST BE
 INSTALLED EXACTLY AS SHOWN**

How to construct the Jury strut assembly

Some trimming may be required

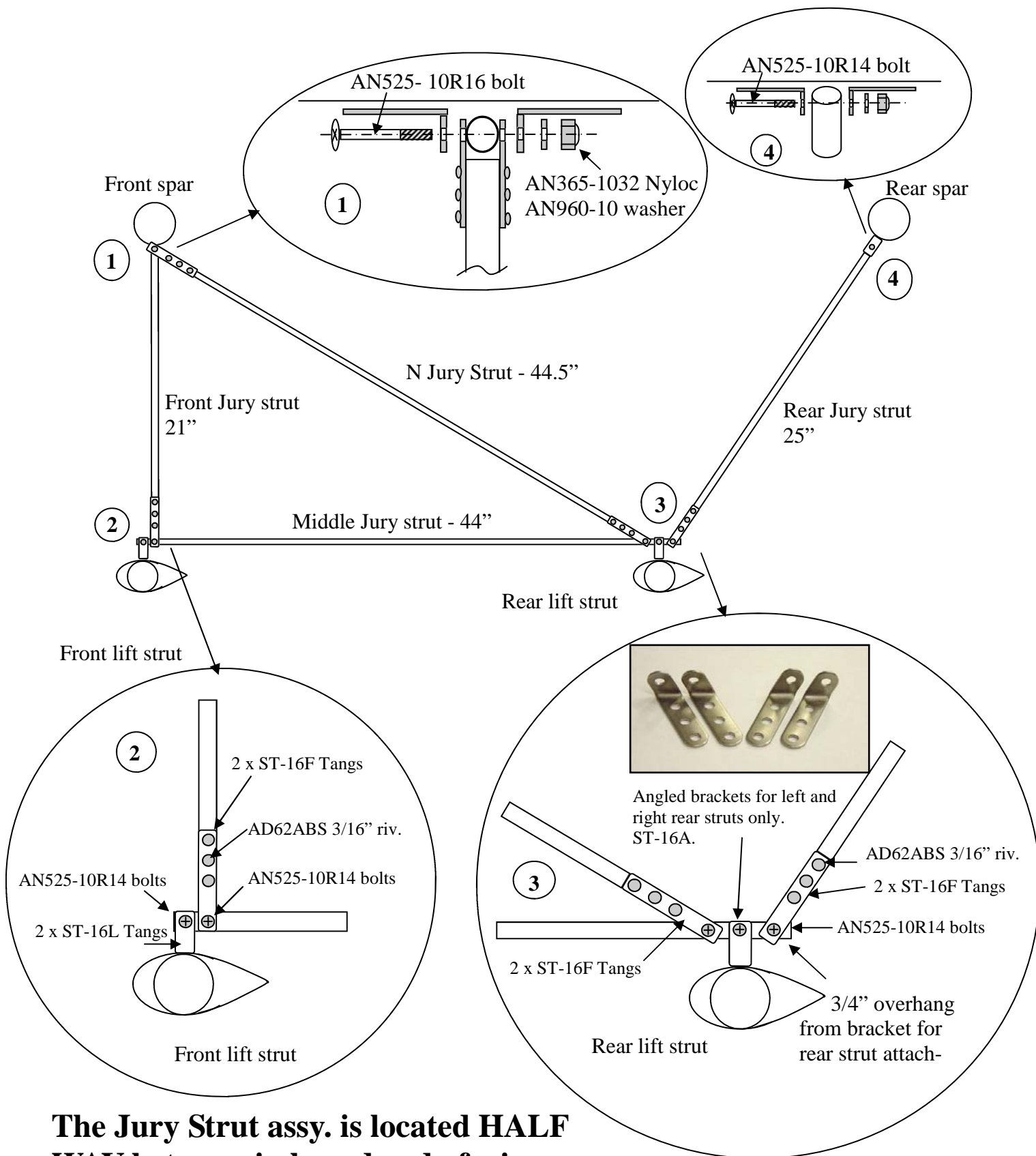

The Jury Strut assy. is located HALF WAY between in board end of wing spar and Lift Strut brackets.

Mark location halfway between inboard end of spar and strut attach brackets. Clamp ST-16L in place. (1/2" apart).

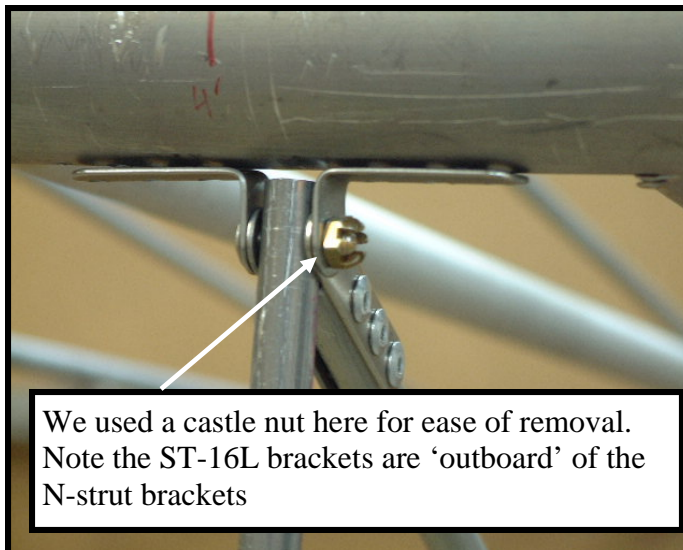
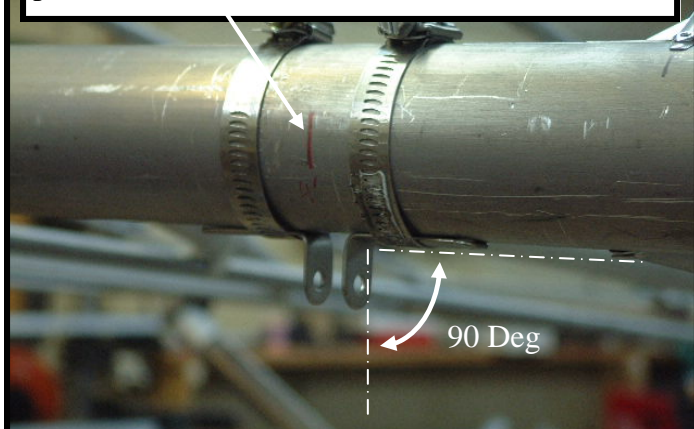

We used a castle nut here for ease of removal. Note the ST-16L brackets are 'outboard' of the N-strut brackets

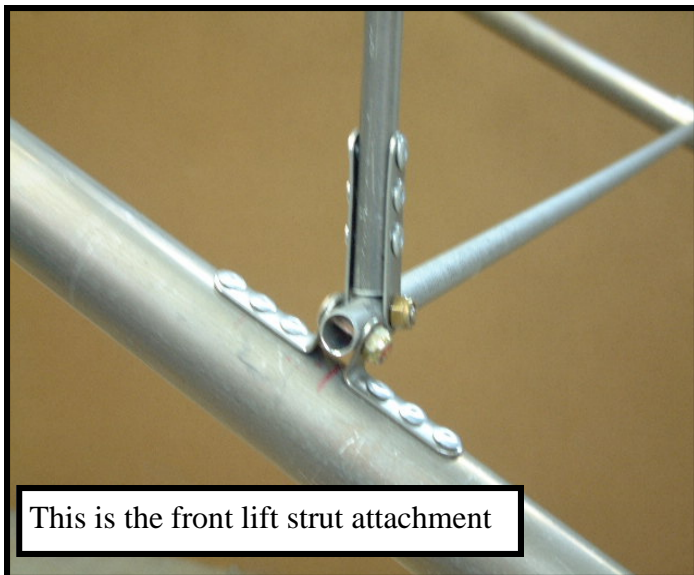

This is the front lift strut attachment

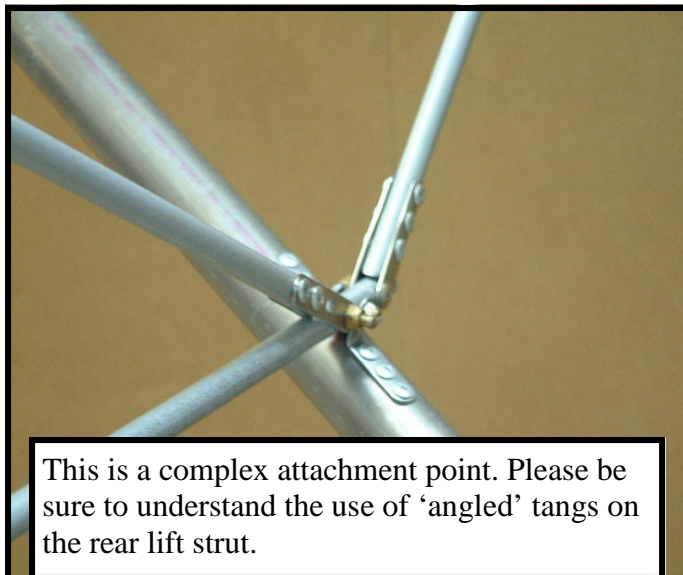

This is a complex attachment point. Please be sure to understand the use of 'angled' tangs on the rear lift strut.

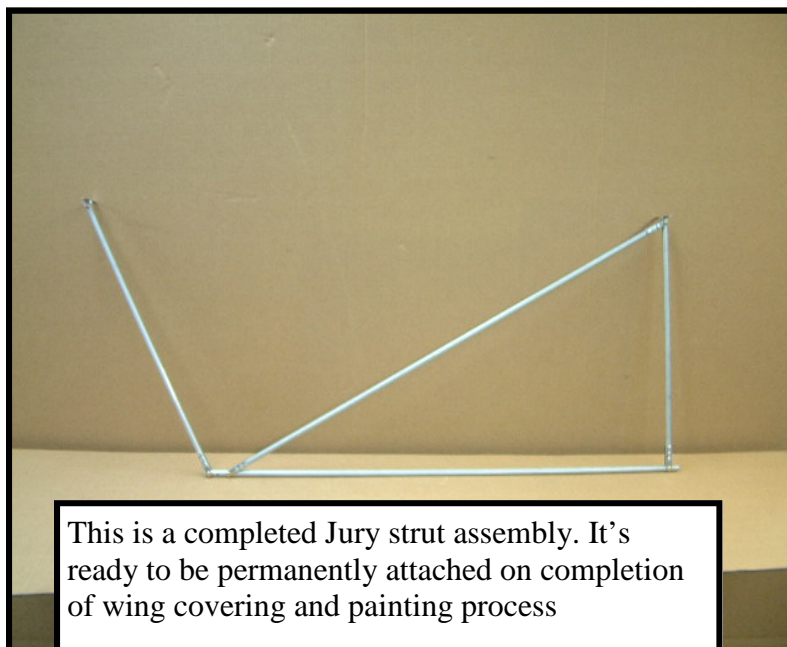

This is a completed Jury strut assembly. It's ready to be permanently attached on completion of wing covering and painting process

How to install SS Fairings to main lift struts.

1.

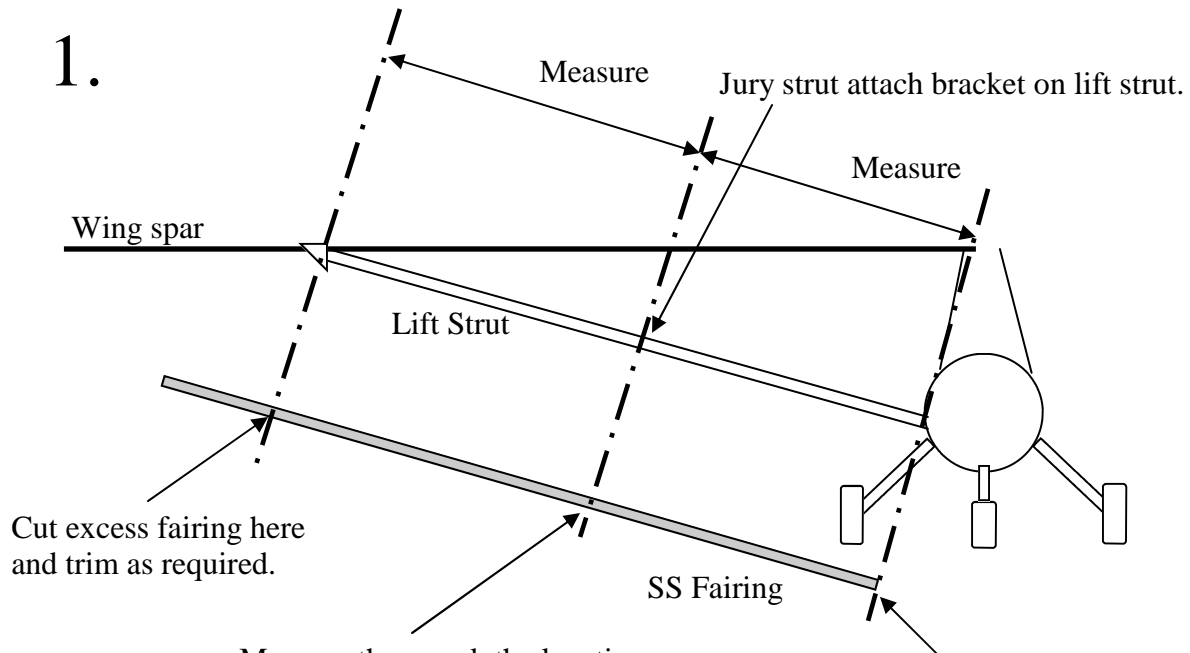

Cut excess fairing here and trim as required.

Measure then mark the location for Jury Strut attach brackets that are riveted to the lift strut. Accuracy is essential here. Measure twice, cut once !

Trim this end as required. An angled cut and some creative trimming around the Rony bracket will give you a nicer finish.

2.

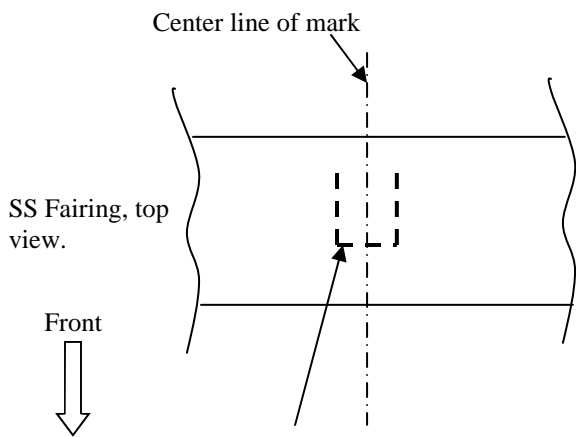
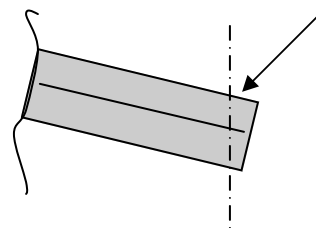

Cut a three sided box shape, approx 3/4" wide on center.

3.

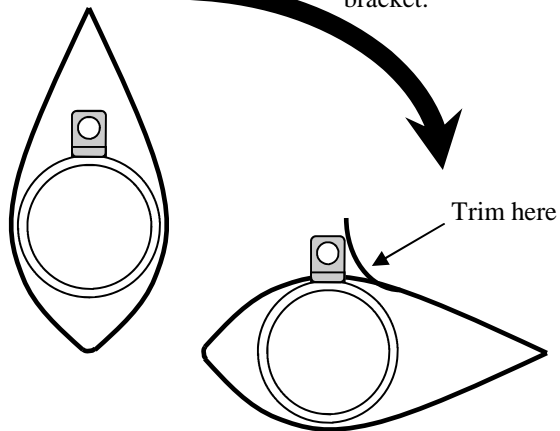

Finally, slide the SS Fairing on the lift strut until the cut part is aligned with the Jury strut bracket, then ROTATE the fairing to expose the bracket.

Repeat this process for each lift strut.

How to install SS Fairings to Jury Struts.

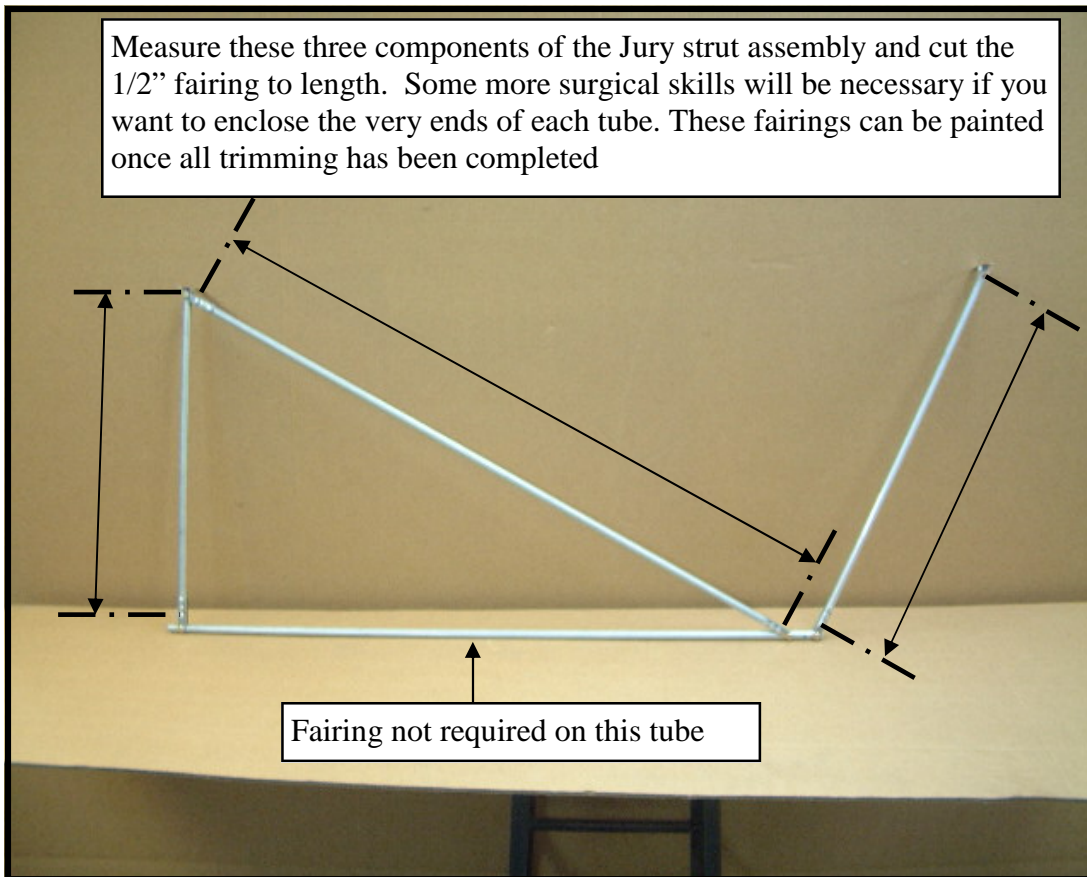

How to install SS Fairings to Horizontal Stabilizer Struts

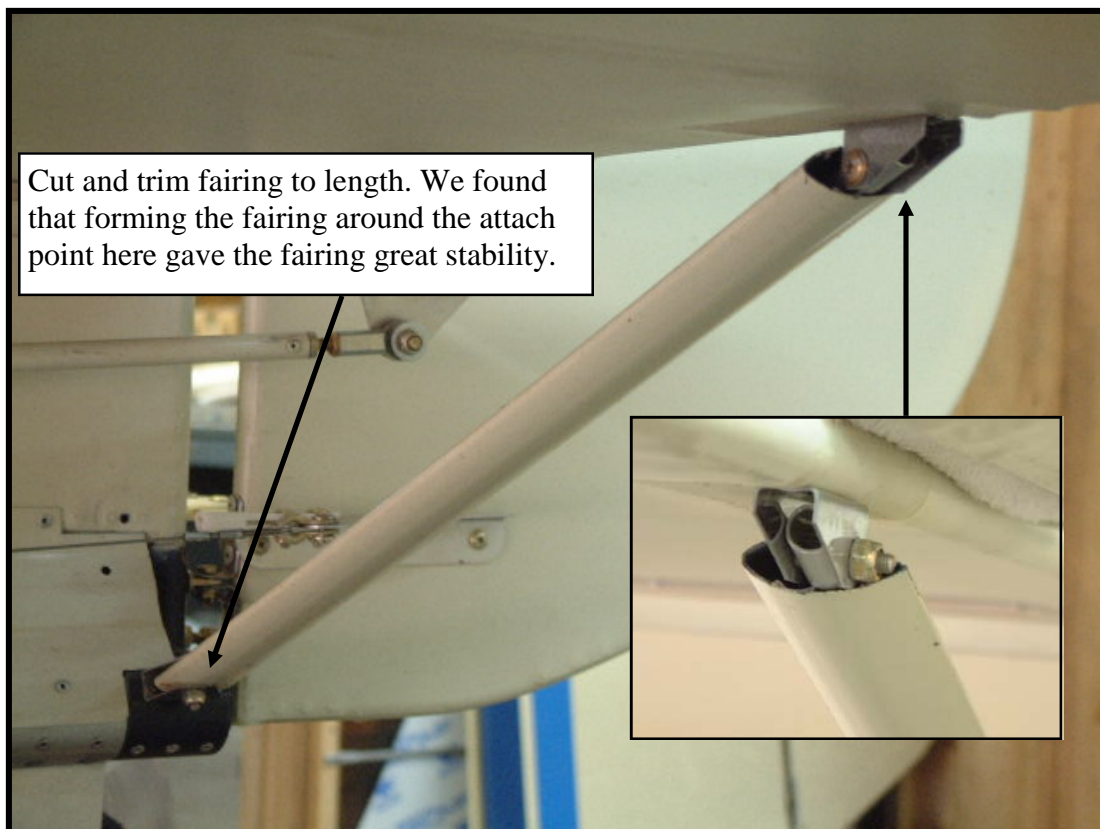

How to make gap seals for the tail section. (Optional).

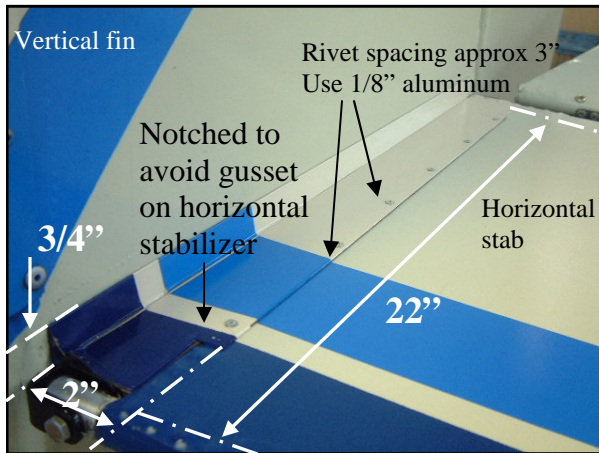

Obtain 2 x 22" lengths of lexan and bend a 3/4" x 90 deg angle along one edge. Slide the bend up to the Vertical fin and rivet in place on the in-board tube of the horizontal stabilizer.

This can now be colored to match your paint scheme. We used sign makers vinyl tape in this example.

NOTE: If you wish to cover the bottom gap on the horizontal stab, be sure to trim enough space to view the attach bolts and rony brackets for pre-flight inspection. Leave space to insert wrenches.

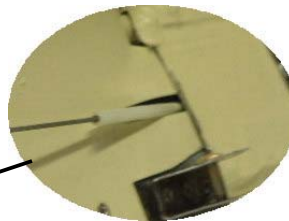
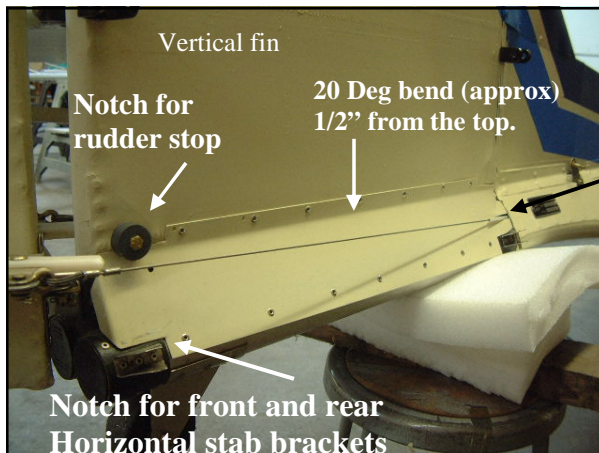

These gap covers are made of .025 sheet aluminum pieces 26" long and 4" wide. We put a bend in at the top of about 20 deg. Then we notched out on the bottom for the horizontal stab strut brackets and rudder stop/gusset. A channel was made for the rudder cable and we riveted using 1/8" alum shorts.

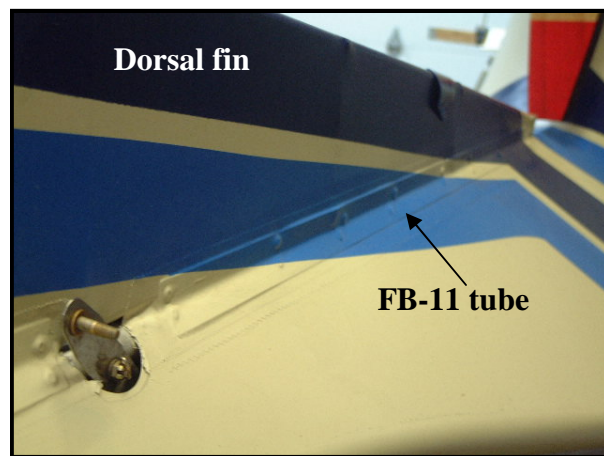
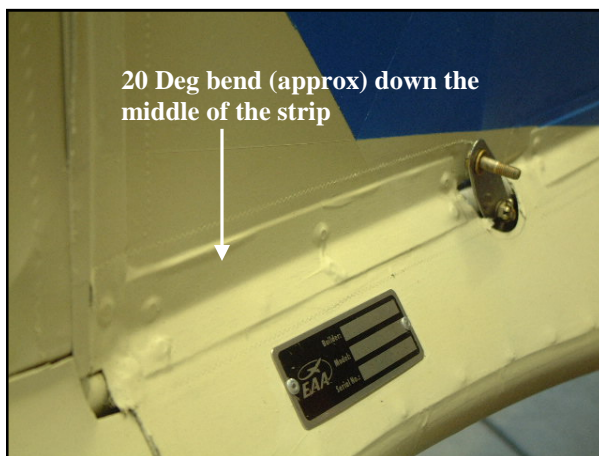

On the Dorsal fin, we used .025 sheet aluminum cut into 1 1/2" wide strips and riveted to the dorsal fin and FB-11 tube. 1/8" alum short rivets were used and we then covered it with 2" finishing tape. We glued the finishing tape down with Poly-Brush as smoothly as possible for a clean finish. We did not heat shrink any of these tapes, but we did run an iron along the serrated edges of the finishing tape to smooth them out before painting.

How to install Aileron push rods

Note: Refer to the Flaperon installation instructions before attempting to align ailerons

Assemble and install the aileron push rod assemblies. Make sure that the control stick is centered side to side, the aileron bell cranks are neutral, the flaperons slide is in it's middle setting and that the ailerons are level with the **BOTTOM** of the wing.

Before cutting aileron pushrod to length, make sure that you have adjustment of the threaded rod end in both directions (bottom out threaded rod and then turn out 6 full turns).

Once you are sure everything is in order, cut aileron tube to length and rivet clevis fork, then attach rod end to aileron horn.

The top factory drilled hole in the aileron horn is for calm weather flying. For more aileron throw, move ball joint to bottom hole. This will also give you more flaperons control.

But be sure that this does not interfere with full aileron travel with the flaperons in their full up or down position! And neither aileron should deflect more than 45 deg. Down. (too much down deflection may stall-out that aileron and 'roll' control may be adversely affected.

Locate the turnbuckles used to connect the aileron control cables to the control sticks in the cockpit. These turnbuckles have been installed at the factory and are used for tensioning of the aileron control cables. Adjust the turnbuckles so that the aileron bell cranks (on the 2" square root tube) are in their neutral position when the control sticks are centered left to right. Don't over tighten the turnbuckles as this will create friction in the system and lead to premature wear of the cables.

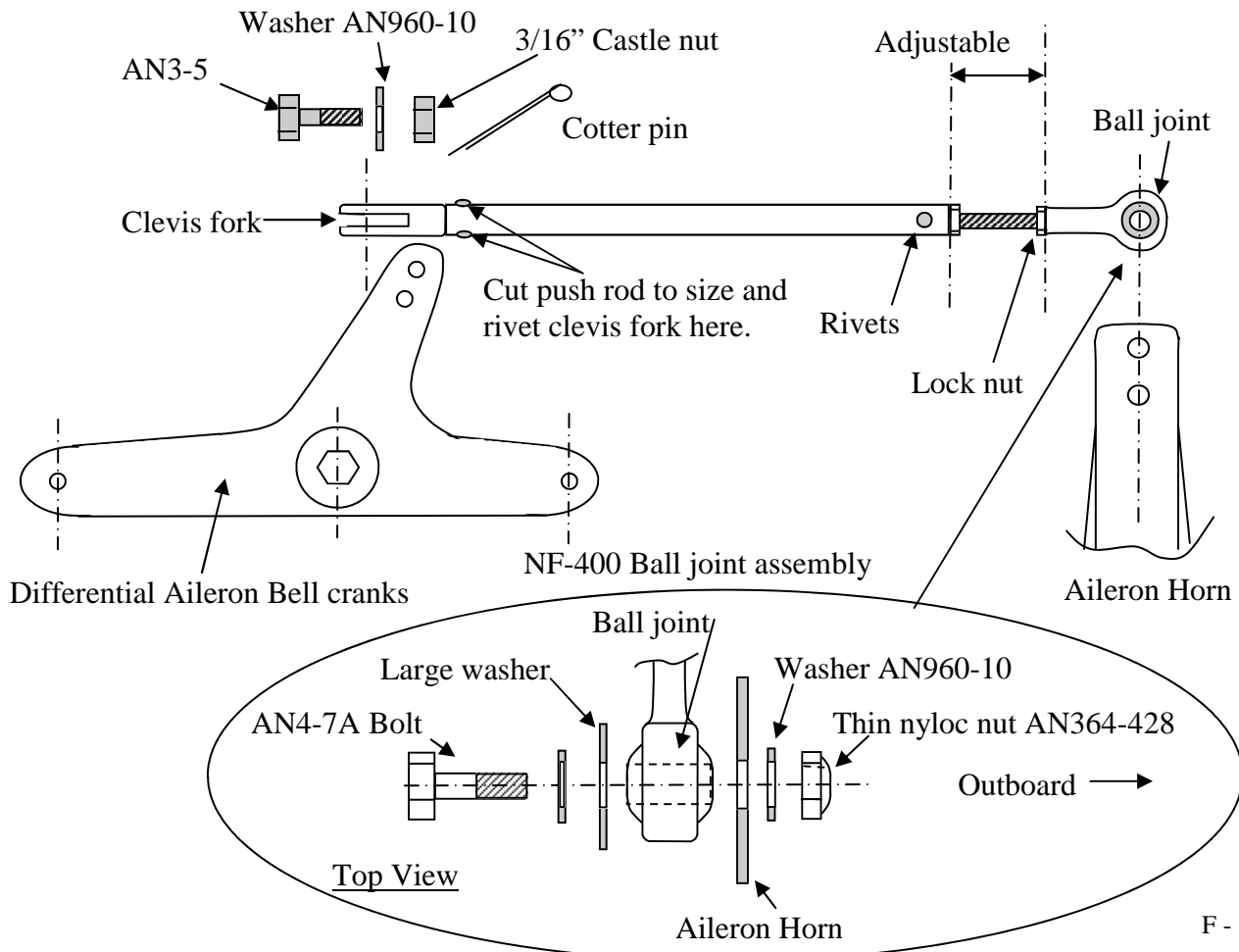

How to install Aileron push rods

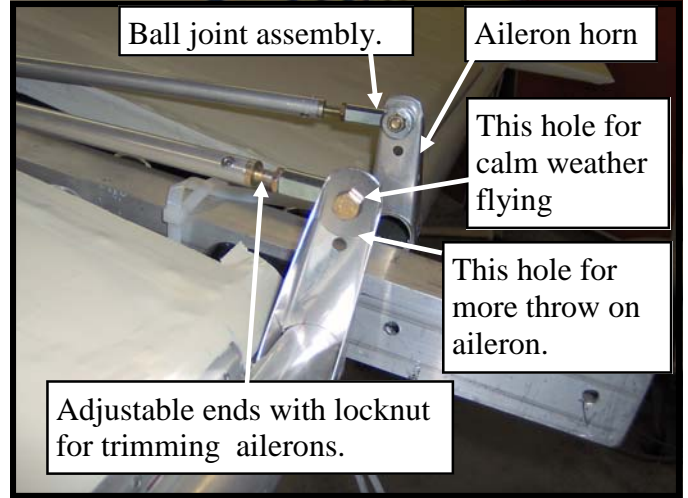
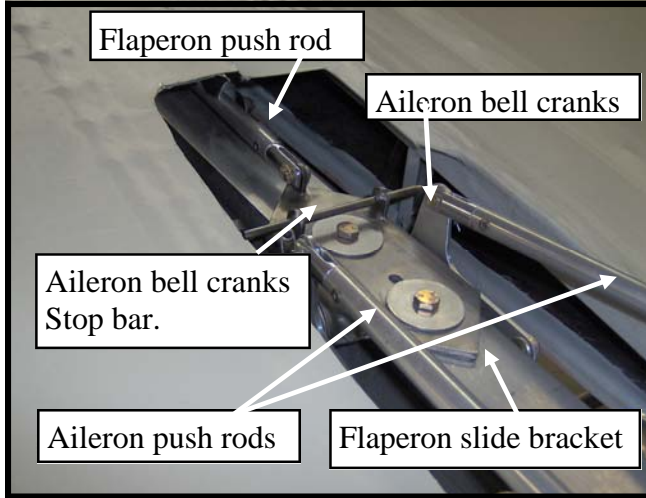

Aileron control turn buckles

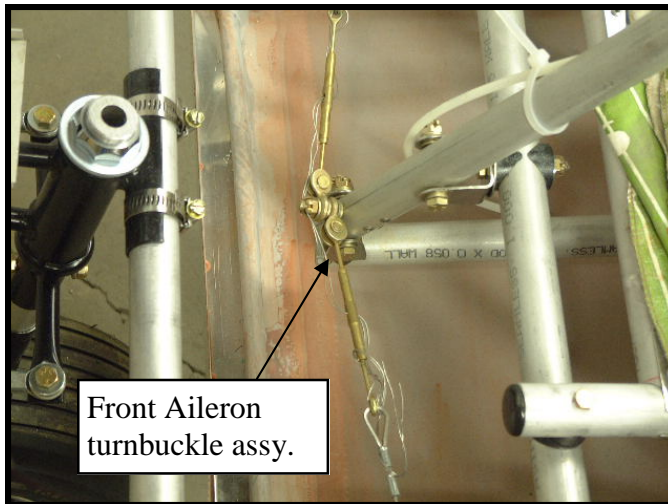

NOTE: The aircraft is shipped with safety wire temporarily woven through the turnbuckles. This is must be re-safe tied to an FAA approved standard before inspection and flight.

SAFETY METHODS FOR TURNBUCKLES

Safety all turnbuckles with .040 diameter annealed safety wire using either the double or single wrap as described and illustrated. Do not reuse safety wire. Adjust the turnbuckle to the correct cable tension so that no more than three threads are exposed on either side of the turnbuckle barrel. Do not lubricate turnbuckles.

(A) DOUBLE WRAP (SPIRAL)

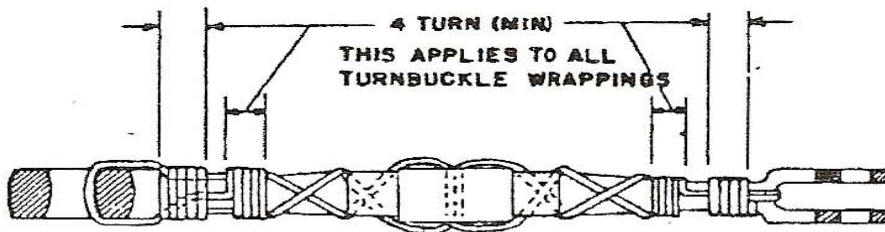

Of the methods using safety wire for safetying turnbuckles, the method described here is preferred, although either of the other methods described are satisfactory. The method of double wrap safetying is shown in figure (A). Use two separate lengths of the proper wire. Run one end of the wire through the hole in the barrel of the turnbuckle and bend the end of the wire towards opposite ends of the turnbuckle. Then pass the second length of the wire into the hole in the barrel and bend the ends along the barrel on the opposite side first. Spiral the two wires in opposite directions around the barrel to cross each other twice between the center hole and the ends. Then pass the wires at the end of the turnbuckle in opposite directions through the holes in the turnbuckle eyes or between the jaws of the turnbuckle fork as applicable, laying one wire along the barrel and wrapping the other at least four times around shank of the turnbuckle and binding the laid wires in place before cutting the wrapped wire off. Wrap the remaining length of safety wire at least four turns around the shank and cut it off. Repeat the procedure at the opposite end of the turnbuckle.

(B) DOUBLE WRAP

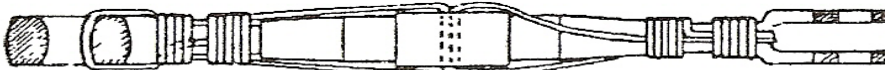

Another satisfactory double wrap method is similar to Method A, except that the spiraling of the wires is omitted as shown in figure (B).

(C) SINGLE WRAP (SPIRAL)

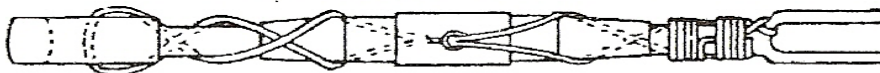

The single wrap methods described and illustrated are acceptable but are not the equal of the double wrap methods.

Pass a single length of wire through the cable eye or fork at either end of the turnbuckle assembly. Spiral each of the wire ends in opposite directions around the first half of the turnbuckle so as to cross each other twice. Thread both wire ends through the hole in the middle of the barrel so that the third crossing of the wire ends is in the hole. Again, spiral the two wire ends in opposite directions around the remaining half of the turnbuckle, crossing them twice. Then, pass one wire end through the cable eye or fork in the manner described above, wrap both wire ends around the shank for at least four turns each, cutting off excess wire.

(D) SINGLE WRAP



Pass one length of wire through the center hole of the turnbuckle and bend the wire ends toward opposite ends of the turnbuckle. Then pass each wire end through the cable eye or fork and wrap each wire end around the shank for at least four times, cutting off excess wire. After safetying, no more than three threads of the turnbuckle terminal should be exposed.