

**Check the relevant hardware pertaining to your specific order.**

**ENGINE PACKAGE**

- 1 Engine (with oil injection) Serial number: \_\_\_\_\_
- Rotax 447 SDCI
- Rotax 503 DCDI
- Rotax 582 DCDI
- 1 973 198 Rotax side mount muffler (447 & 503)
- 1 973 197 Rotax side mount muffler (582)
- 1 973 184 Rotax exhaust elbow (447, 503 & 582)
- 1 878 937 Rotax manifold (447)
- 1 878 937 Rotax manifold (503 & 582)
- 1 bottle two cycle oil (packed in motor)
- 1 Prop 60 x 44 (503)
- 1 Prop 60 x 42 (447)
- 7 938 795 Rotax exhaust springs
- 1 SP2706 K&N air filter (447)
- 1 SP2705 K&N air filter (503)
- 1 SP2703 K&N air filter (582)
- 1 CC-100 Choke cable single carburetor
- 1 CC-102 Choke cable dual carburetor
- 1 TACH-T tini tach (dash mount—sometimes in instrument package)
- 1 HTD-100-R reduction drive (Rotax)

**MUFFLER BRACKET AND HARDWARE BAG**

- 1 Muffler bracket (packed in motor box for Rotax 447 & 503 only)
- 2 423 435 (8mm replacement head bolt)
- 2 5/16" flat hardware washer
- 4 Rubber grommets (2 x 9406 male - 2 x 8316 female)
- 2 1/4" x 28 x 2" grade 8 bolts
- 8 AN960-416 (1/4" washers)
- 2 AN363-428 (1/4" high temp lock nut)
- 4ft safety wire.

**MOTOR MOUNT HARDWARE**

- 1 MP-447 Motor mount plate
- 1 MP-503/582 Motor mount plate
- 2 MM-1 (2" x 2"x 3/16" Alum. Motor mount angles)
- 2 MM-2 (1 1/4" square alum. Motor mount spacers)
- 2 AN5-52A bolts (engine mount)
- 2 AN365-524 Nyloc nut
- 2 AN960-516 washer
- 8 AN4-16A bolt
- 8 AN365-428 Nyloc nut
- 8 AN960-416 Washer
- 32 AN525-832R10 (screw bolt - for Lord mount)
- 32 AN365-832 (5/32" Nylon nut - for Lord mount)
- 8 150PL-30 rubber lord mounts
- 4 1/4" Stainless steel large area washer.

# How to drill out the M.M Angles and Plate

ONLY ONE MOTOR MOUNT ANGLE IS FACTORY DRILLED. MATCH DRILL THE UNDRILLED ANGLE USING THE DRILLED ANGLE AS A GUIDE

## Step # 1

1. Clamp angles together with this end flush and all other edges flush.

2. Drill through 5/16" holes with 5/16" bit using factory drilled hole as a guide.

3. Rotate left angle 90 deg. to the left and rotate right angle 90. deg to the right

4. Clamp angles together with the SAME END flush and all other edges flush.

5. Drill through 1/4" holes with 1/4" bit using factory drilled hole as a guide.

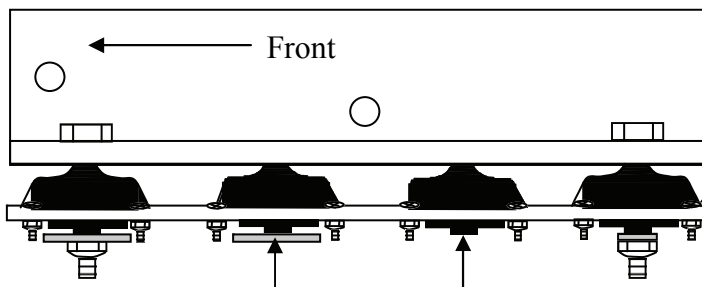

6. Drill holes on the motor mount plate using the lord mount holes as a guide with 5/32" drill bit. Install the 5/32" bolts and nyloc nuts See page 47.

7. Drill remaining 1/4" holes through lord mount bushings with 1/4" drill bit. Be sure to install large area washers on the front 4 lord mounts

## Motor mount angles viewed from left side - Rotax 503 configuration

Step # 2

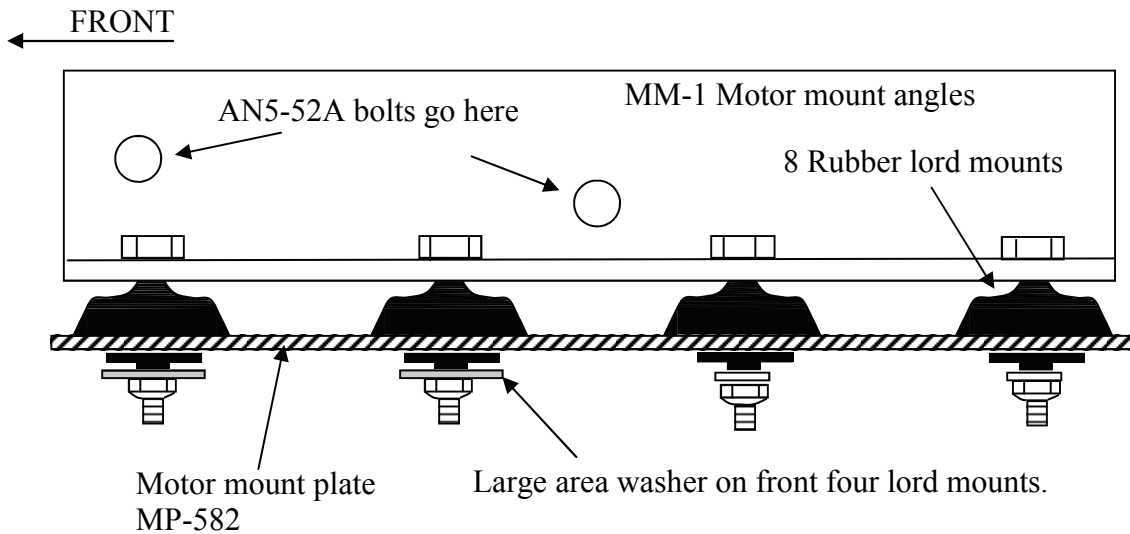

## Motor mount angles viewed from left side - Rotax 447 configuration

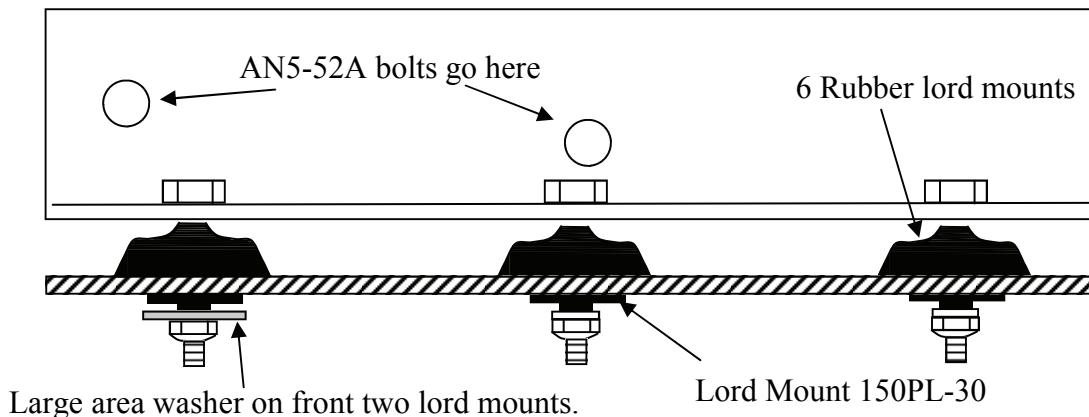

Attach the rubber Lord mounts to the engine mounting plate as shown on page 46. The Lord mounts are installed on TOP of the plate with the higher pointed end facing UP. The 5/32" holes will have to be drilled in the plate. Install the 8 (6 for Rotax 447) with the 32 x AN525-832R10 bolts and nuts provided.

Install the motor mount plate assembly on the engine with the Lord mounts on the top side. Secure with metric nuts and lock washers provided with engine (should be in the box with the carburetors). Be sure to use RED loc-tite on these nuts and **torque to 28ft lbs.**

Install the motor mount angles to the top side of the Lord mount as shown above .

Install engine to fuselage root tube using 5/16" (AN5-52A) bolts, washers and Nyloc nuts. Do not over tighten nuts ! The 2" Square root tube should not be compressed more than 1/16"

# Rotax Engine Motor mount detail

Step # 3

Top View

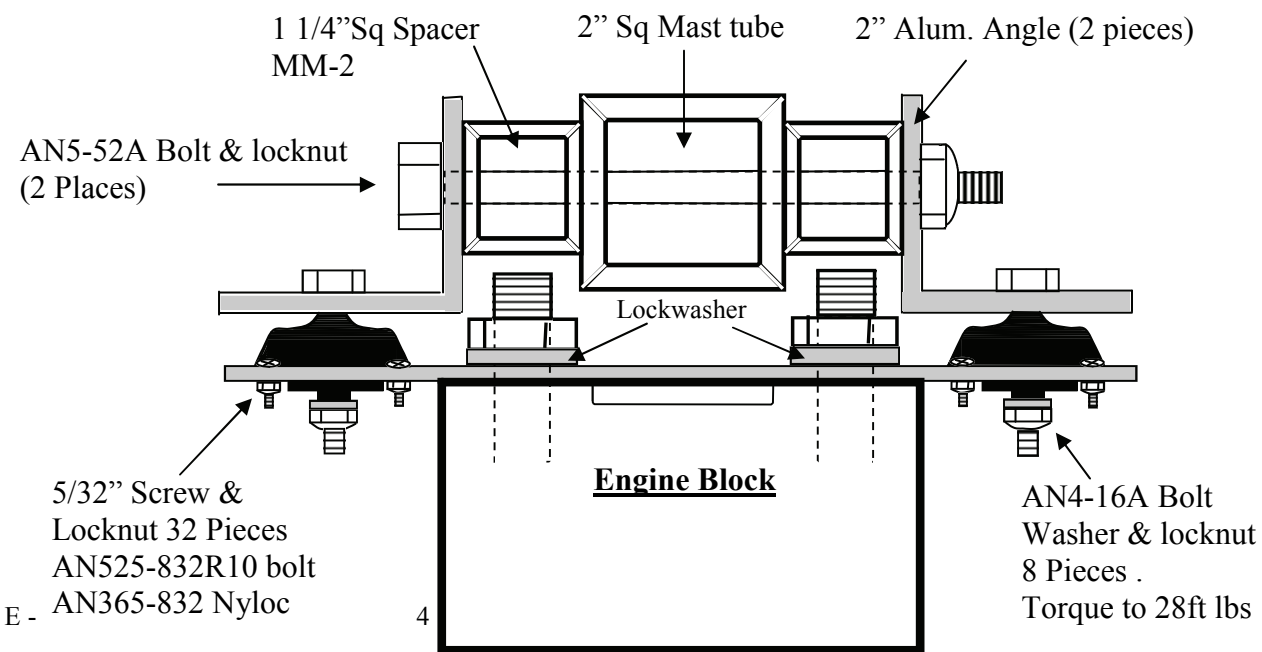
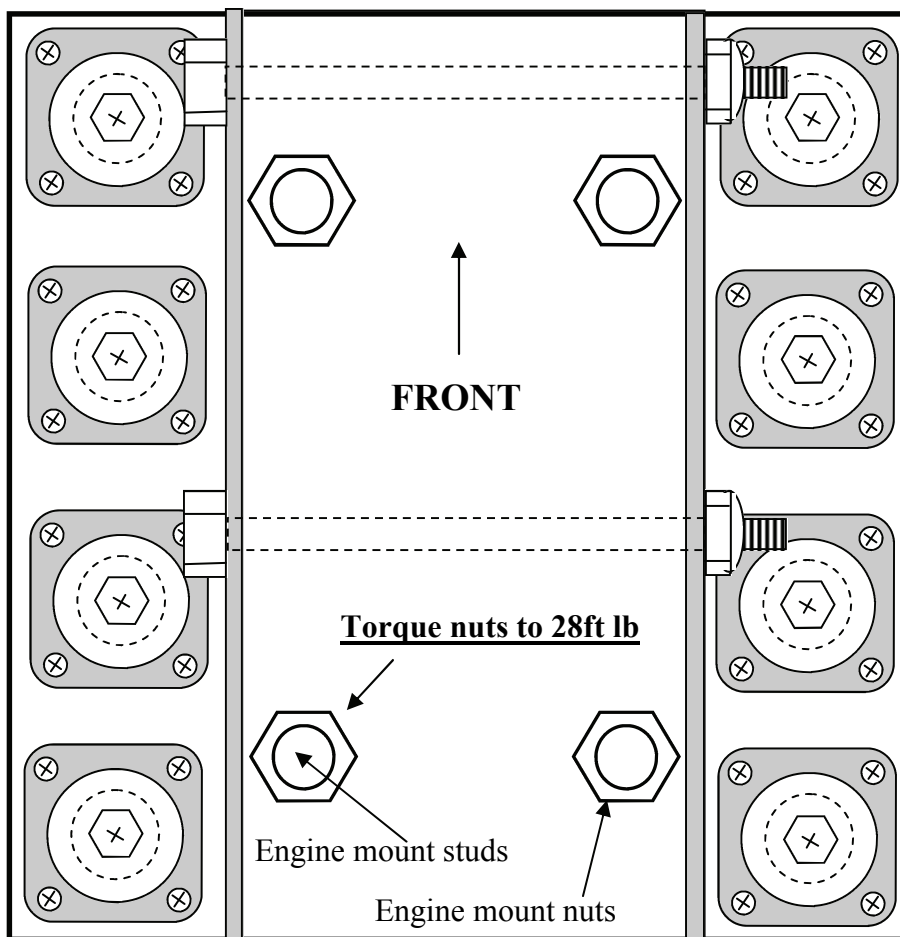

E.

## How to mount the fuel pump

### Step # 4

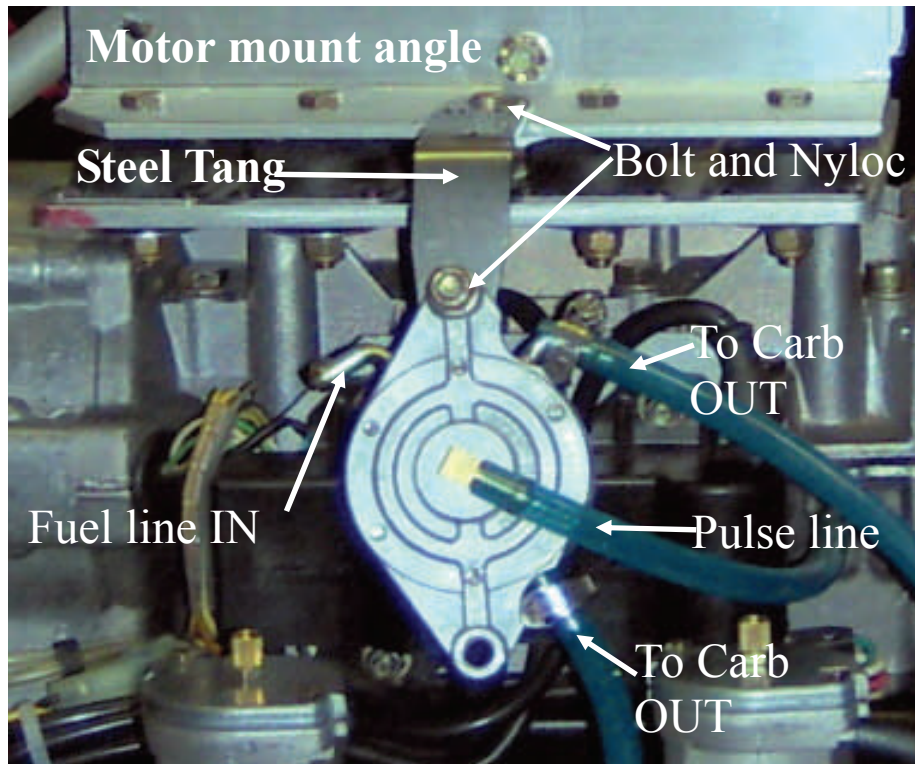

Fashion a tang to mount the fuel pump to the Motor mount angle NOT the engine or engine plate. The preferred material is steel (or mild steel).

Ensure the pump is far enough away from the coils as not to hit them (or any other component) during engine operation but close as possible to the pressure nipple on the engine case with the shortest possible pressure (vacuum - pulse) line

All fuel line attachments must have a Stainless steel hose clamp.

### Step # 5 Exhaust manifold

Install Exhaust manifold, muffler and muffler bracket per Rotax engine manual as shown on page 47. Do not torque 8mm bolts that attach muffler bracket to engine, but just tighten them until they are snug. Be sure male rubber washers are seated in muffler bracket tab hole. Do not overtighten 1/4" x 2" grade 8 bolts on muffler bracket clamp portion, as this may cause premature failure of these bolts (just tight enough that they don't rattle). Don't forget to safety wire the 8mm bolts. Hi-Temp anti-seize exhaust lubricant is recommended for the muffler to exhaust manifold ball joint. Be sure to safety wire the exhaust springs so they don't go through the propeller.

### Step # 6 Carburetors

Install carburetors per Rotax Engine manual. The arrow on the rubber carb connectors points toward the engine. For best idle, we find that the main needle in the carb slide should be in it's leanest position (retaining clip in top slot on needle) and the small brass air bleed screw should be turned out about 2 turns from bottom. Install throttle cables and levers. Adjust cables so there is 1/8" play where cable housing enters top of carb. Cable adjusters on top of carb should be in a position to allow for adjustment up or down for differences in ambient temperature (on warm days the cable housing will lengthen slightly and may require adjustment to prevent too fast an idle).

# Throttle and Oil injector cable assembly.

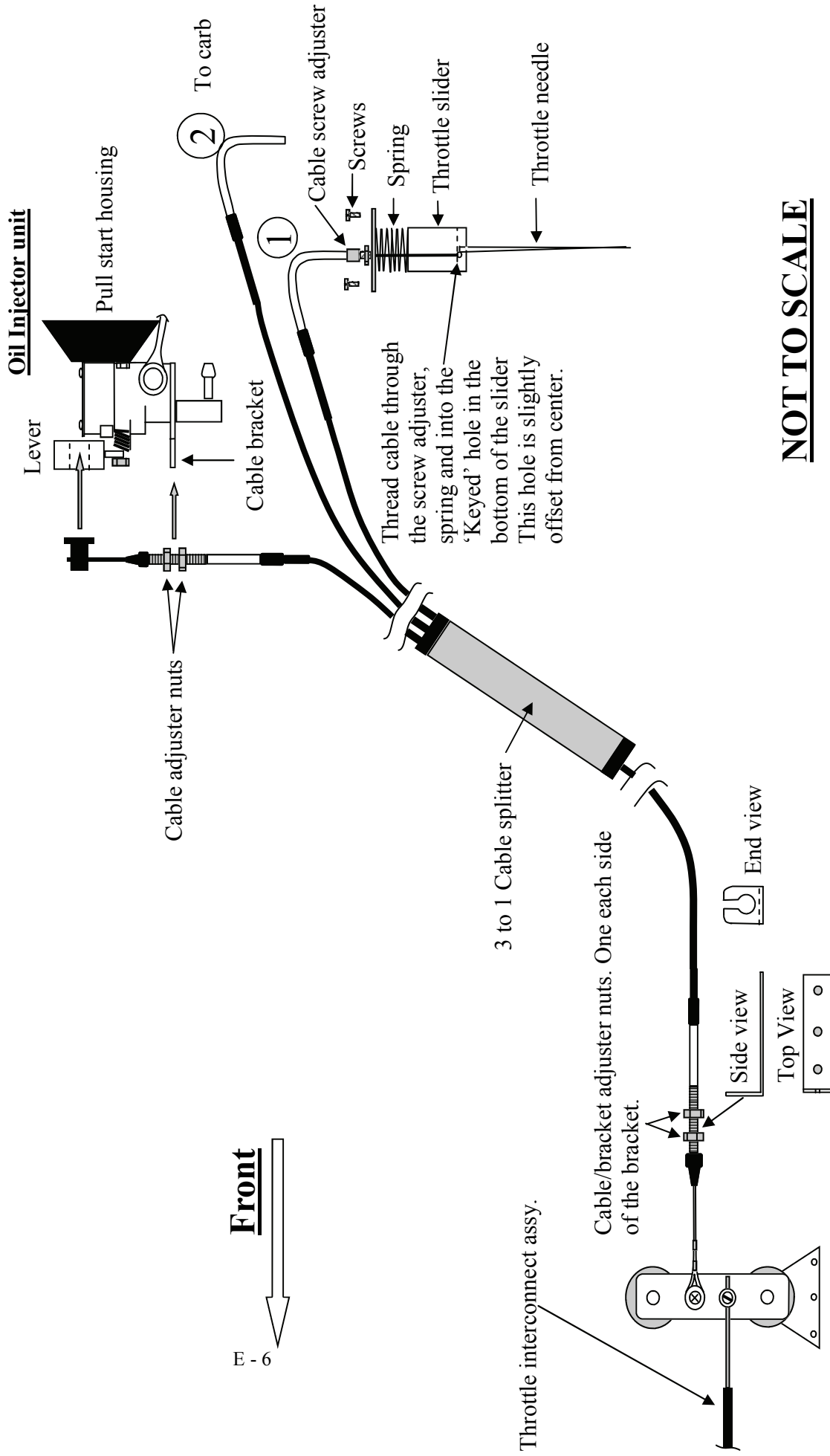

Rear throttle assembly

ST16-L-T Bracket attached to cockpit side rail. 3 x AD42ABS alum rivets (short).

## 3 Piece Rotax exhaust and Muffler bracket system

Step # 5

**TOP VIEW**

**Rear**



**Safety wire ALL springs !**

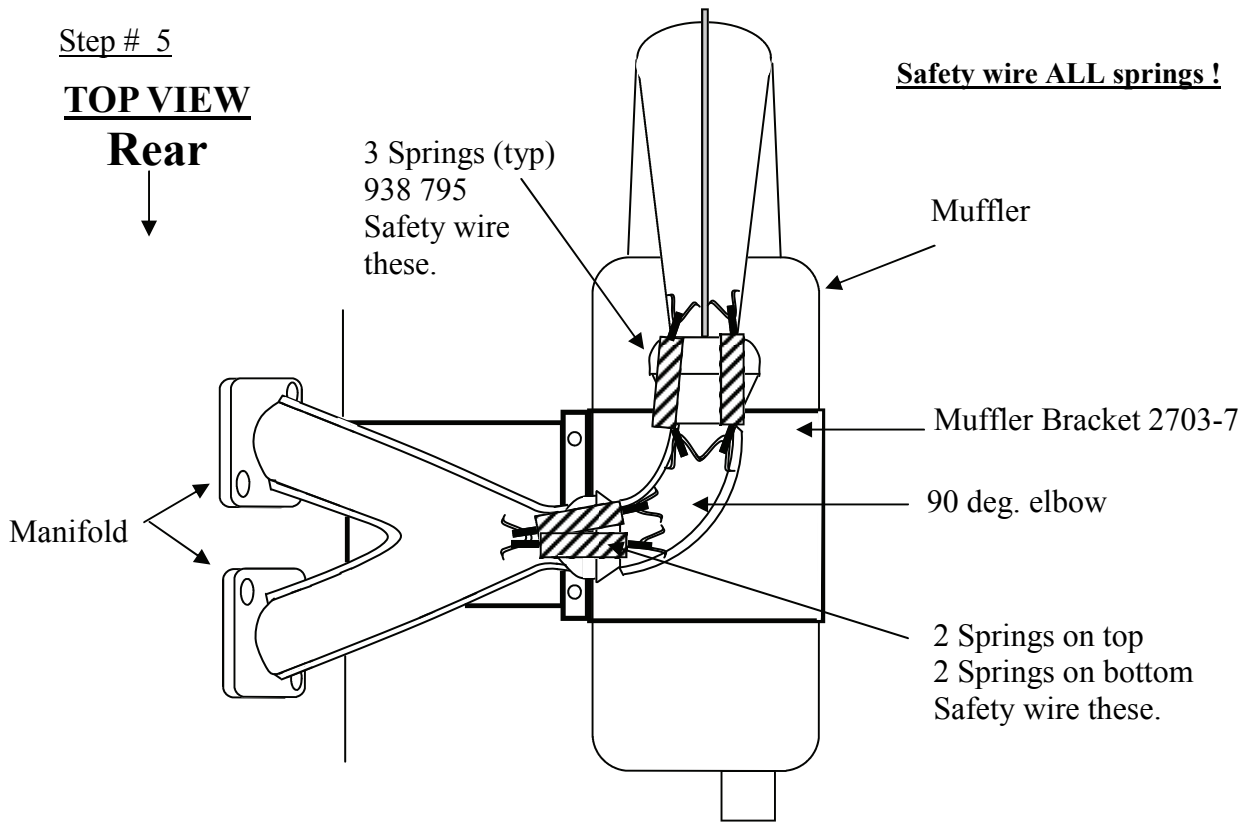

## How to attach muffler for Rotax 447 & 503 engines

For 582 Engines, call the factory.

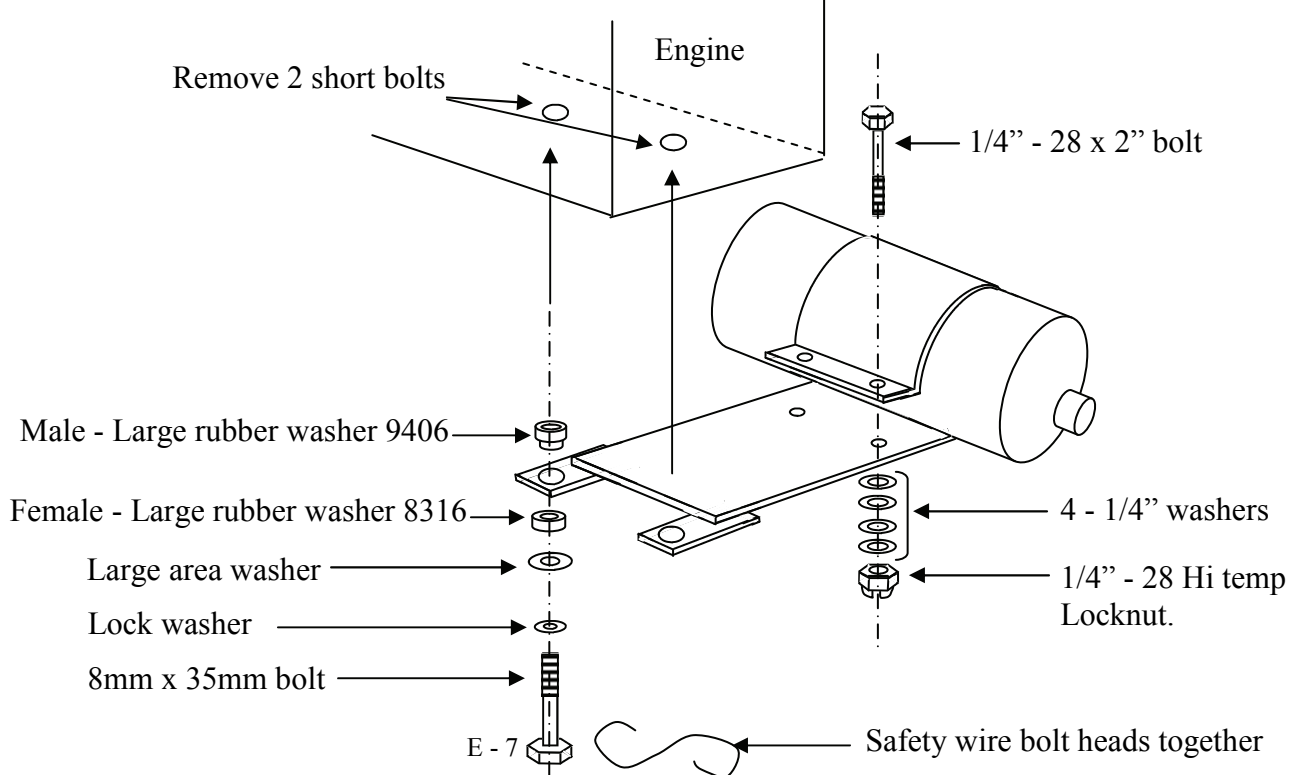

## How to install the 2.6 : 1 Cog belt reduction drive

### Step # 7

**NOTE:** In November of 1994, Quad City Ultralights changed the drive system from a 2.2 : 1 ratio with a 54" propeller to a 2.6 : 1 ratio with a 60" propeller. (60x44)

Belt reduction allows the Challenger to swing a bigger diameter propeller and is smoother than a gear drive. Care must be taken to install the reduction drive system properly to get the maximum life from the drive belt and the engine.

Begin by bolting the reduction tower to the output end of the engine with eight bolts provided (Hirth use 6 bolts). Make certain the mating surfaces are flat, smooth and free of burrs. Install mounting bolts with #271 Red Loc-tite and torque to 15ft lb. With QCU starter, see starter instructions.

Next, install the small drive pulley on the output shaft with the 1/2" x 20 bolt, thick washer and lock washer provided (use loc-tite on this bolt) and torque to 50ft lbs. (Be sure to lock Rotax engine by inserting a locking pin provided in Rotax tool kit into the vacuum nipple on the side of the engine).

Now install the adjuster bracket and large (driven) pulley to tower and snug up the large nut.

### Pulley alignment

Check for proper pulley alignment between the drive pulley and driven pulley (large pulley) by placing a straight edge on the face of both pulleys.

### Belt tension

Tighten the adjuster bolt on the adjuster bracket until correct tension is achieved and snug up the large castle nut. Remember, when tightened, the shaft is forced straight and the belt becomes tighter. With the large nut snug, re-check tension. See diagram xxx for proper tensioning. When you are satisfied with the belt tension, torque the large castle nut on the casting side to **150-200 ft lbs.** (hold the shaft from turning with a wrench on the square portion of shaft). Install 1/8" cotter pin, bend over and trim ends.

Back off the adjuster bolt, apply a small drop of loc-tite and screw down until bolt touches the top of the mount plate. Loc-tite the jam nuts and torque to about 15ft lbs.

Install the propeller hub with 6 allen bolts. Loc-tite and torque to 15ft lbs. Install the propeller per instruction manual. (Sect III).

Check belt tension and torque values every 50 hours of operation.

Belts should last 200 or more hours, but we recommend replacing after 100 hours of operation or every 12 months, whichever comes first. (200 hours or 2 years on GT-2 belts).

At 500 hours we recommend replacing the prop shaft bearings in the top pulley. These bearings are installed in the top pulley at the factory, but can easily be replaced with the use of an Arbor press.



## Reduction drive detail

**NOT TO SCALE**

Step # 7

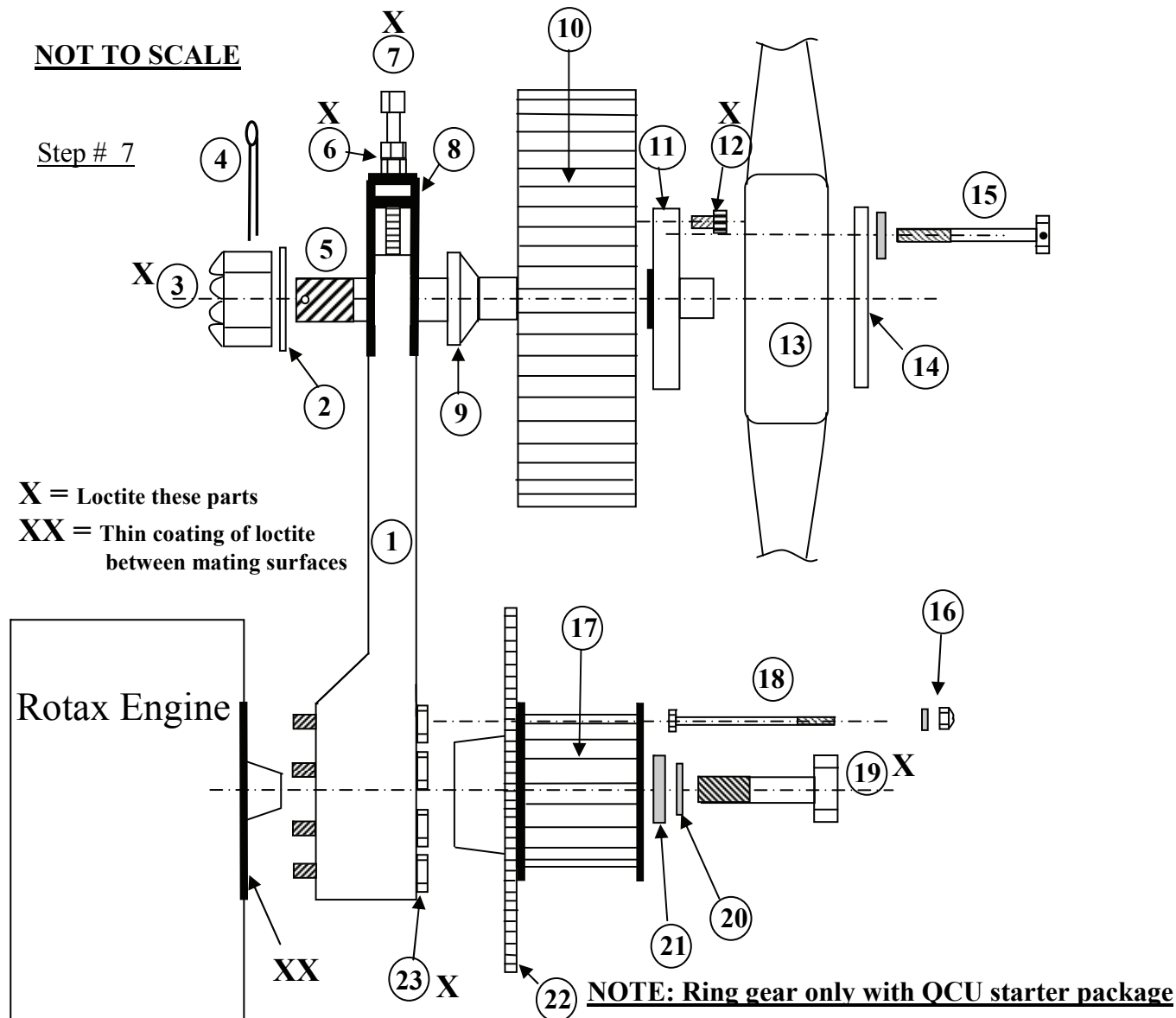

1. Reduction tower (spacer incorporated)
3. 1" Castle nut (Torque 125 - 175ft lb).
5. Pulley Shaft (4140 Chromalloy).
7. Adjuster bolt (3/8" grade 8).
9. Thrust washer (Stainless steel)
11. Propeller hub (6061-T6 Alum).

13. Propeller
15. Prop mounting bolts (& washers)  
x 6 (drilled head). HTD-021
17. Bottom pulley

19. 1/2" bottom pulley bolt (1/2" x 2-1/2"  
SAE fine grade - Torque to 50ft lb)
21. 1/2" Extra thick washer (stainless steel)
23. Re-drive mount bolts x 8. (8mm x 70mm torque  
to 15ft lb Rotax - 10mm x 50mm Hirth torque to 20ft lb)

2. 1" AN960-1616 Washer
4. 1/8" cotter pin
6. Adjuster brkt jam nuts x 2 (3/8" zinc)
8. Adjuster bracket HTD-012 (s. steel).
10. Top Pulley (6061-T6511 Alum).
12. Hub mounting bolts x 6 (5/16" socket  
Head. HTD-007 - Torque to 15ft lb)
14. Propeller face plate - HTD-008

16. 6 x AN365-1032 nyloc nuts and washers
18. 6 x AN3-26A bolts with ring gear  
(AN3-24A without starter package)
20. 1/2" lock washer

22. Ring gear - for Starter motor assy.

# How to check belt tension and alignment for 2.6 : 1 Reduction drives

Step # 8

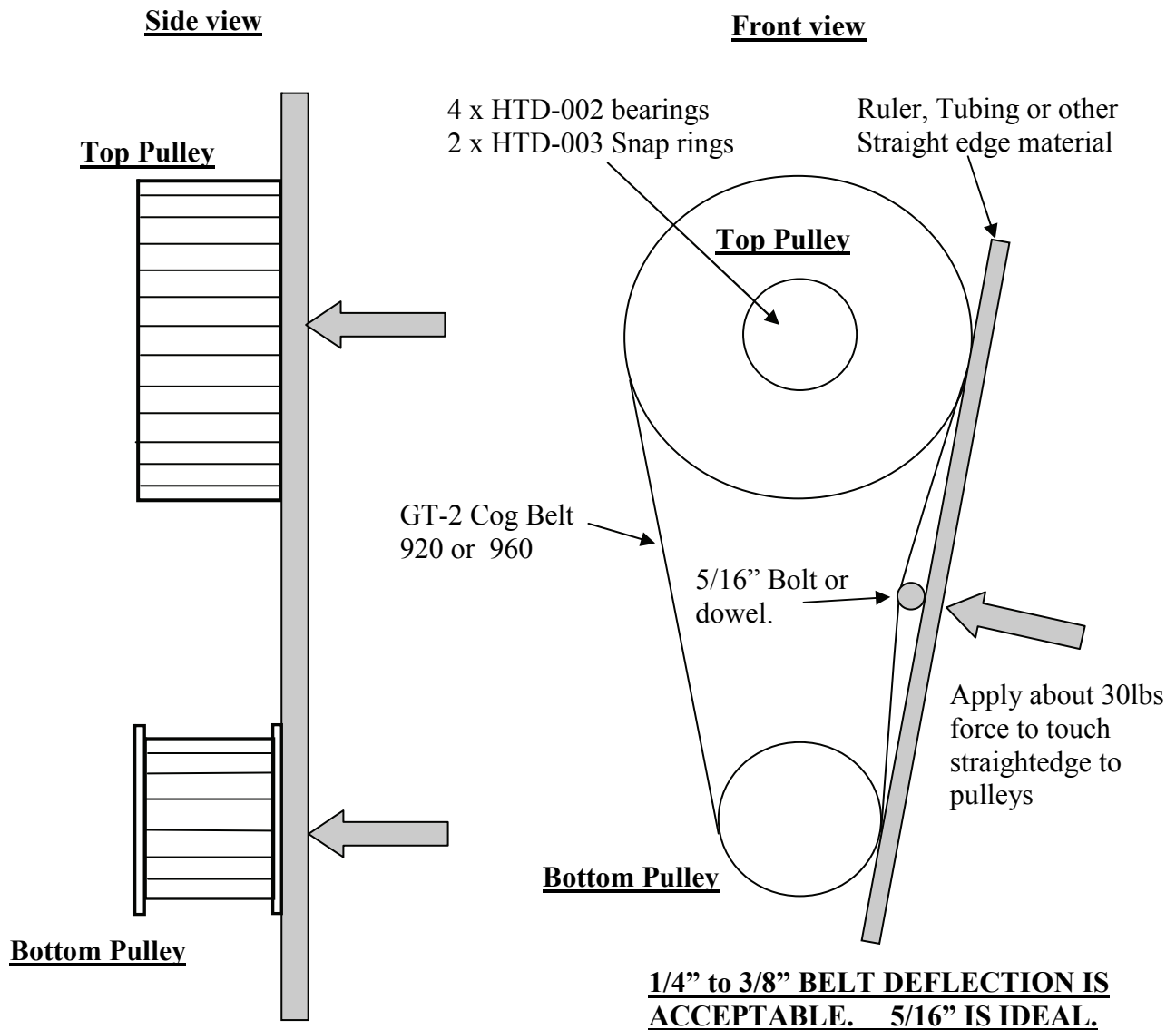

Run a straight edge as shown above to make sure the top and bottom pulleys are aligned.

## How to install the propeller

Step # 9

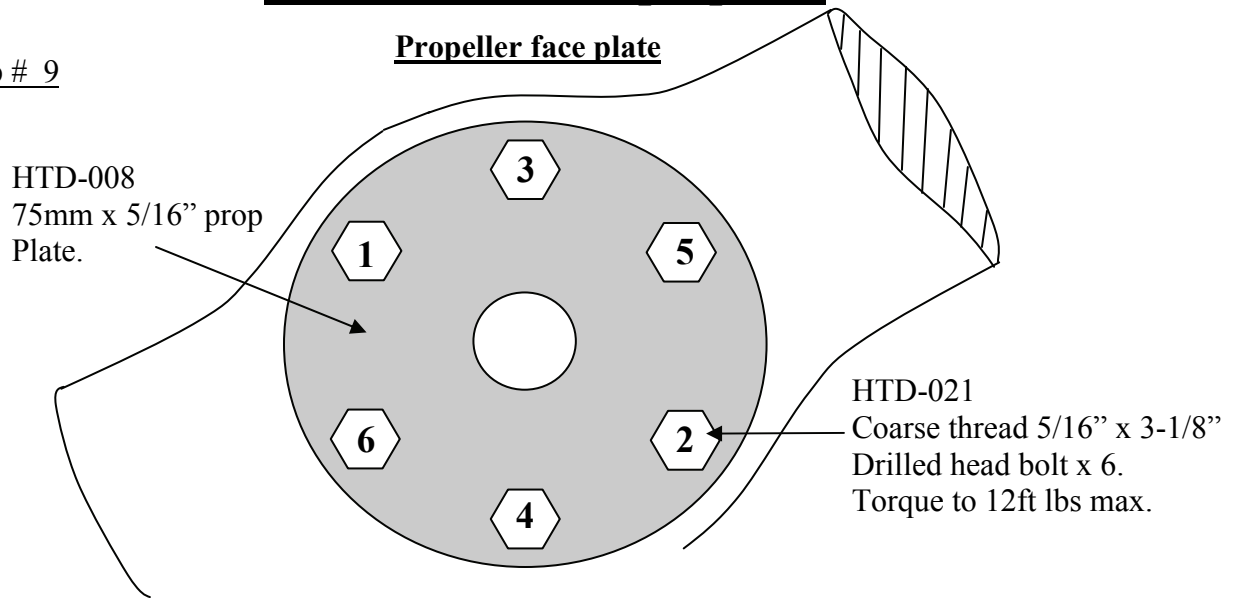

Install Propeller and prop plate with the 6 coarse thread 5/16 bolts (drilled head) provided. Be sure that the flat side of the prop is to the rear and the airfoil side of the prop is to the front. Do not over-tighten propeller bolts (12ft lbs. MAX). **Tighten in sequence indicated above.** Try to tighten prop bolts equally to prevent propeller from being pulled out of 'track'. Safety wire prop (reference below) with wire provided. Since prop bolts are 'safetied', you need not use Loc-tite on threads.

### CAUTION:

Before running engine, see Rotax engine manual and proper break-in procedure.

### Safety wire reference

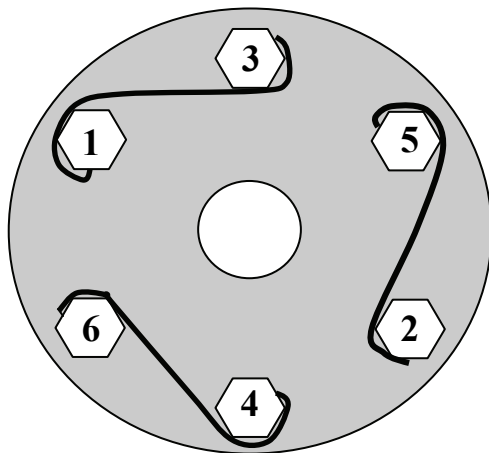

Bolt loosens by unscrewing to the left

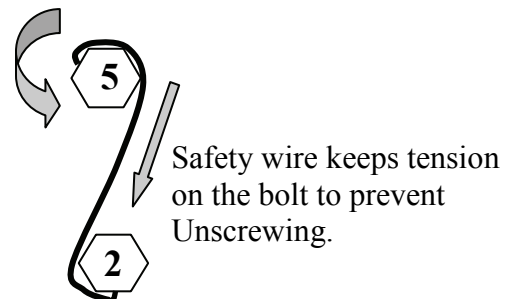

## Finishing up - Weight and balance

### Step # 10

The following few pages contain information on the weight and balance of the Challenger aircraft. Some FAA inspectors want to see an actual weight and balance calculation on your plane before they will give you an airworthiness certificate. We have included a sample form on one of our planes and a blank one for you to use on your plane.

Remember - **If the nose wheel does not stay down** with the pilot sitting in the front seat with the engine NOT running, you are too tail heavy and must add ballast to the nose.

If you **weigh more than 250 lbs.**, you will probably be nose heavy unless you have the Rotax 503 with electric start system.

Generally speaking, the Challenger II will come out **Tail Heavy** if the following things are true.

1. Pilot weighs less than 150lbs.
2. Too much paint is put on the tail surfaces
3. '503' engine, ten gallon tank and / or electric starter is installed.

If 1,2 & 3 are all true, you may need as much as 25lbs of ballast attached to the steel nose gear carrier assembly to balance the aircraft.

If you are slightly nose heavy, you will have to fly with the ailerons or flaperons in a more up (reflex) position. If you are slightly tail heavy, you will have to fly with the ailerons or flaperons in a more down (flap) position. Adjust your aileron pushrods accordingly. Elevator trim tabs may also be used (tab down for nose up trim).

### **IMPORTANT NOTE:**

**Before attempting to start the engine, taxi or fly your Challenger, refer to and read carefully the owners manual. Set-up, pre-flight inspection, warnings and specific information vital to safe, proper operation are contained in that manual.**

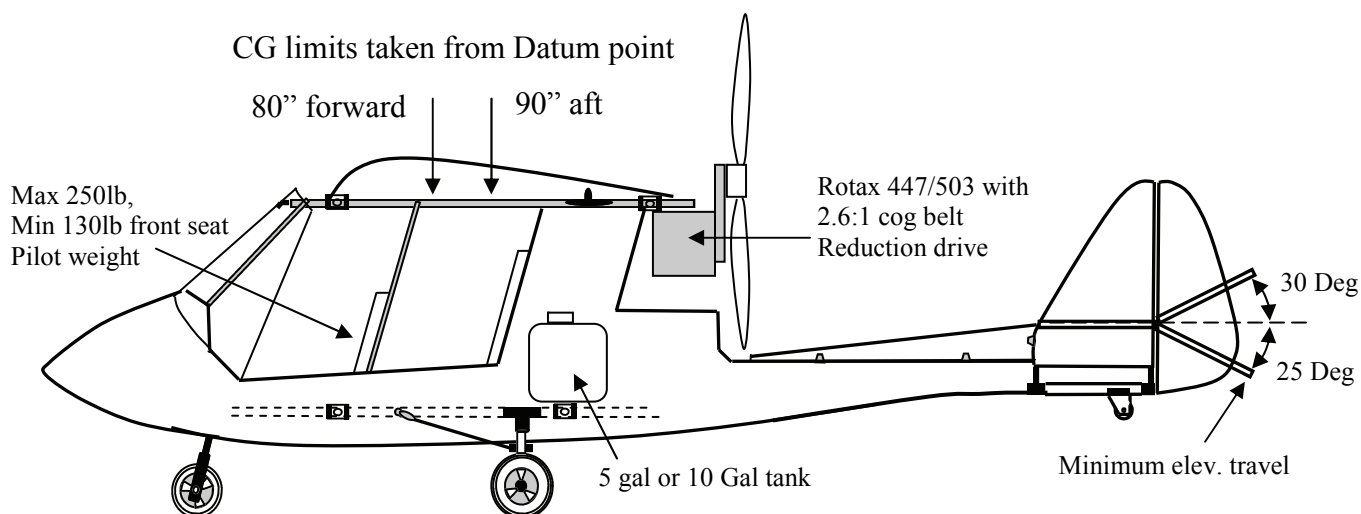

# Weight & Balance, Challenger II Clipped wing & LSS only

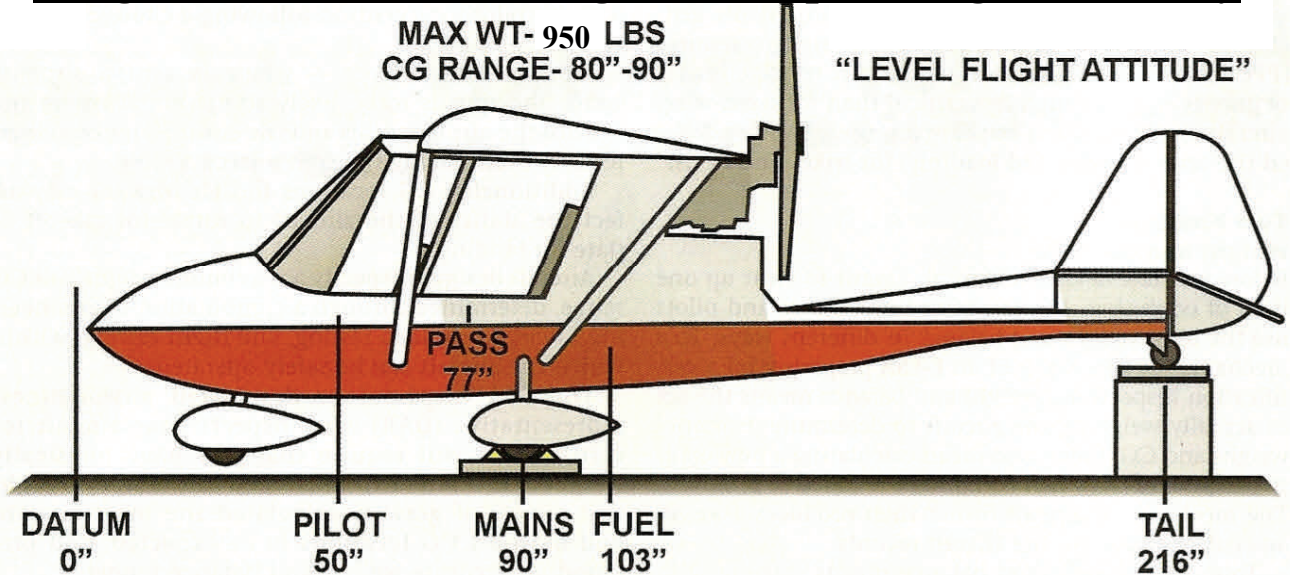

## Detailed Instructions

**\*DATUM:** A fixed point from which all measurements are taken.

**\*ARM:** Distance from the Datum to the center of mass of a specified object.

**Example:** The arm of the tail wheel would be the distance from the datum to the center bolt of the tailwheel. Prior to weighing, the aircraft should be thoroughly cleaned and serviced. Oil and Hydraulic systems should be full, fuel should be drained to an "un-useable" level, and all accessories should be in place. Weighing may be accomplished with either three scales, or one scale and two blocks the same height as the scale. Blocking should be prepared so that all weight measurements are taken in a level flying attitude.

### Step 1: SETUP

Set up aircraft with blocking and scale(s) to a level flying attitude. With this setup, the nosewheel should not be in direct contact with the ground. See figure above.

### Step 2: WEIGHING MAIN WHEELS

Obtain the weight of the left main wheel and record it on chart A of the Weight & Balance worksheet. If using only one scale, the right main should be resting on a block which is the same thickness as the scale, and the tailwheel should be resting on a similar block in addition to a larger block which represents a level flying attitude, as shown in the figure above. Repeat for the Right main wheel.

### Step 3: WEIGHING TAIL WHEEL

Obtain the weight of the tailwheel and record it on chart A of the Weight & Balance worksheet. If using only one scale, the main wheels should now be supported with scale size blocks.

### Step 4: CALCULATING THE ARM (Chart A)

Using the weight figures obtained in the previous steps, multiply the weight of each wheel by the corresponding arm listed to get the "Moment". Add the moments from left, right and tail wheels to get the "Total Moment". Carry this figure to the next line. Add the weight from left, right and tail wheels to obtain the empty weight. Divide the total moment by the empty weight, the result is the "Arm" for the empty airplane.

### Step 5: CALCULATING GROSS WEIGHT AND CENTER OF BALANCE (Chart B)

Use the figures obtained in chart A to fill in the weight of the empty airplane, its arm, and the moment on chart B. Fill in the front seat (pilot) weight and multiply it by the corresponding arm listed to get the front seat moment. Repeat for the rear seat using the passenger's weight. Fill in the number of gallons of fuel and multiply this number by 6 for fuel weight in pounds or fill in the number of liters and multiply by 1.585 for fuel weight in pounds (do not use both gallons and liters). Multiply the fuel weight by the fuel arm to get the moment. Add the weights for the total gross weight, and add the moments for the total moment. Carry these figures to the next line and divide the total moment by the total weight to get the Center of Gravity. Verify that the total gross weight is under the maximum allowable gross weight, and that the Center of Gravity is within the range recommended by the manufacturer.

# Weight & Balance, Challenger II Clipped wing & LSS only

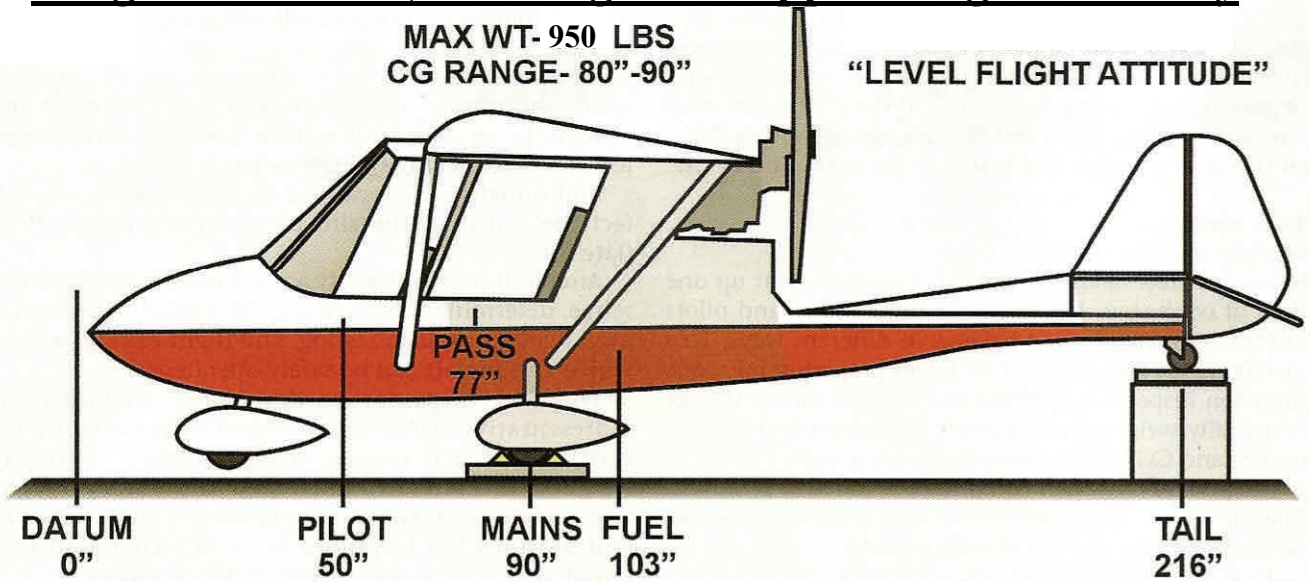

**Chart A**

**Aircraft: N \_\_\_\_\_**

	Weight		Arm		Moment
Left Wheel:	200	lbs.	x 90	"	= 18000
Right Wheel:	200	lbs.	x 90	"	= 18000
Tail Wheel:	44	lbs.	x 216	"	= 9504
<b>Total Empty Weight:</b>	<b>444</b>	lbs.	<b>Total Moment (inch/lbs):</b>		<b>45504</b>
<b>Total Moment (inch/lbs):</b>	<b>45504</b>	=		<b>102.46</b>	Arm (Empty airplane)
<b>Total Empty Weight (lbs):</b>	<b>444</b>				

\*Notes: Empty weight does not include useable fuel. Aircraft must be weighed in a level flying attitude. Scale should be placed above blocking for tail wheel, or the weight of the blocking deducted from tailwheel weight if blocking is above scale.

**Chart B**

	Weight		Arm		Moment
Empty Airplane:	444	lbs.	x 102.46	"	= 45504
Front Seat (Pilot):	170	lbs.	x 50	"	= 8500
Rear Seat:	170	lbs.	x 77	"	= 13070
Fuel in Weight: 6 lb per gallon or 1.585 lbs per Litre	60	lbs.	x 103	"	= 6180
<b>Total Gross Weight:</b>	<b>844</b>	lbs.	<b>Total Moment</b>		<b>73274</b>
<b>Total Moment</b>	<b>73274</b>	=		<b>86.81</b>	C.G.
<b>Total Weight</b>	<b>844</b>				

**Max. Allowable Gross Weight: 950 lbs.**  
**Center of Balance Range, from: 80" to 90" from datum.**

# Weight & Balance, Challenger II Clipped wing & LSS only

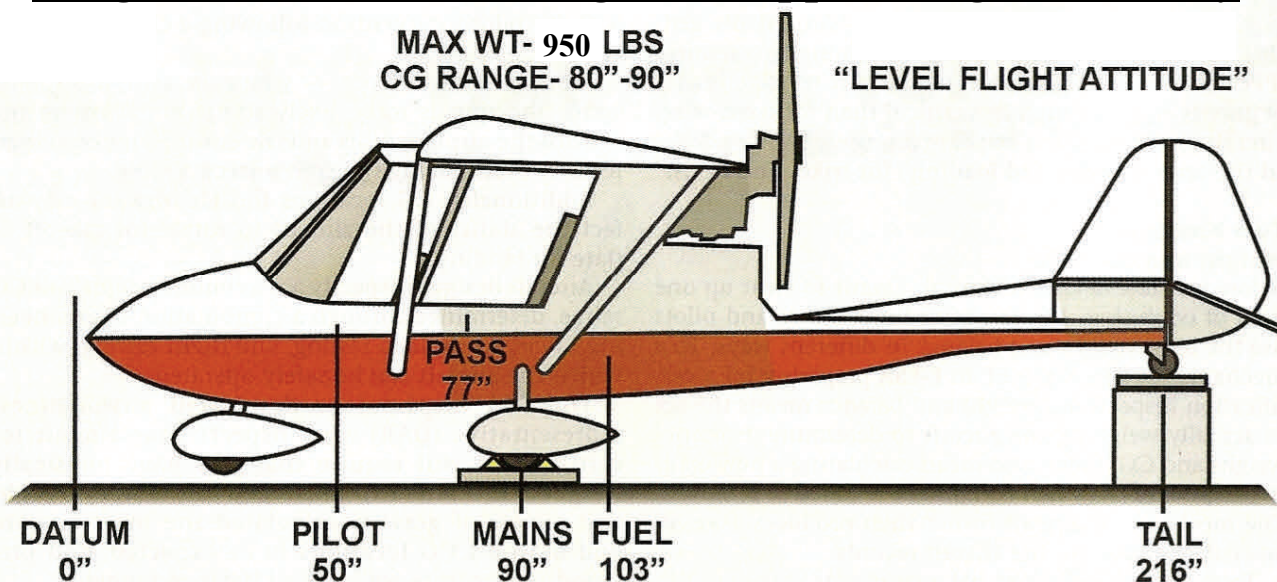

Chart A

Aircraft: N \_\_\_\_\_

	Weight		x	Arm	"	=	Moment
Left Wheel:	_____ lbs.			90	"	=	_____
Right Wheel:	_____ lbs.			90	"	=	_____
Tail Wheel:	_____ lbs.			216	"	=	_____
Total Empty Weight:	_____ lbs.			Total Moment (inch/lbs):			_____
Total Moment (inch/lbs): _____		=				Arm (Empty airplane)	
Total Empty Weight (lbs): _____							

\*Notes: Empty weight does not include useable fuel. Aircraft must be weighed in a level flying attitude. Scale should be placed above blocking for tail wheel, or the weight of the blocking deducted from tailwheel weight if blocking is above scale.

Chart B

	Weight		x	Arm	"	=	Moment
Empty Airplane:	_____ lbs.			_____	"	=	_____
Front Seat (Pilot):	_____ lbs.			50	"	=	_____
Rear Seat:	_____ lbs.			77	"	=	_____
Fuel in Weight:	_____ lbs.			103	"	=	_____
6 lb per gallon or 1.585 lbs per Litre							
Total Gross Weight:		lbs.		Total Moment			
Total Moment _____		=				C.G.	
Total Weight _____							

Max. Allowable Gross Weight: 950 lbs.

Center of Balance Range, from: 80" to 90" from datum.

Cut this page out and photo copy it a few times

## Quick reference page

### Torque specs

#### ENGINE 447/503

<u>Bolt type</u>	<u>Bolt Size</u>	<u>in lbs.</u>	<u>ft lbs.</u>	<u>Loctite</u>
------------------	------------------	----------------	----------------	----------------

#### MOTOR MOUNT HARDWARE

Crank case base nuts		335	28	242
----------------------	--	-----	----	-----

All other bolts on MM hardware have no specific torque setting. Do not over tighten.  
1/16" compression MAXIMUM on the root tube for angle mount bolts - AN5-52A

#### REDUCTION DRIVE

Prop Shaft drive nut	1"		150-200	none
Prop hub mounting bolts	5/16"	180	15	271
Prop mounting bolts	5/16"	180	15	none
Bottom pulley	1/2"	600	50	271
Re-drive mount bolts	8mm (Rotax)	180	15	271
Re-drive mount bolts	10mm (Hirth)	240	20	271

#### STARTER MOTOR HARWARE

Flat head, countersunk-socket cap screws	M8 x 1.25 x 80mm	156	15	271
Hex head bolts	2" x 3/8 x 16 grade 8	156	26	271

FOR ALL ENGINE SPECS, REFER TO ROTAX MANUAL SUPPLIED WITH ENGINE KIT.

FOR ROTAX ENGINE WARRANTY ISSUES, PLEASE CONTACT YOUR DESIGNATED WARRANTY CENTER. (REFER TO PAPER WORK SUPPLIED)

FOR ROTAX NON WARRANTY ISSUES, PLEASE CONTACT:

CALIFORNIA POWER SYSTEMS - 1 800 AIRWOLF

OR

LOCKWOOD AVIATION - 1 800 LA ROTAX