

Installation of Heavy Load Saddle Kit

How to attach Lift Struts to Fuselage

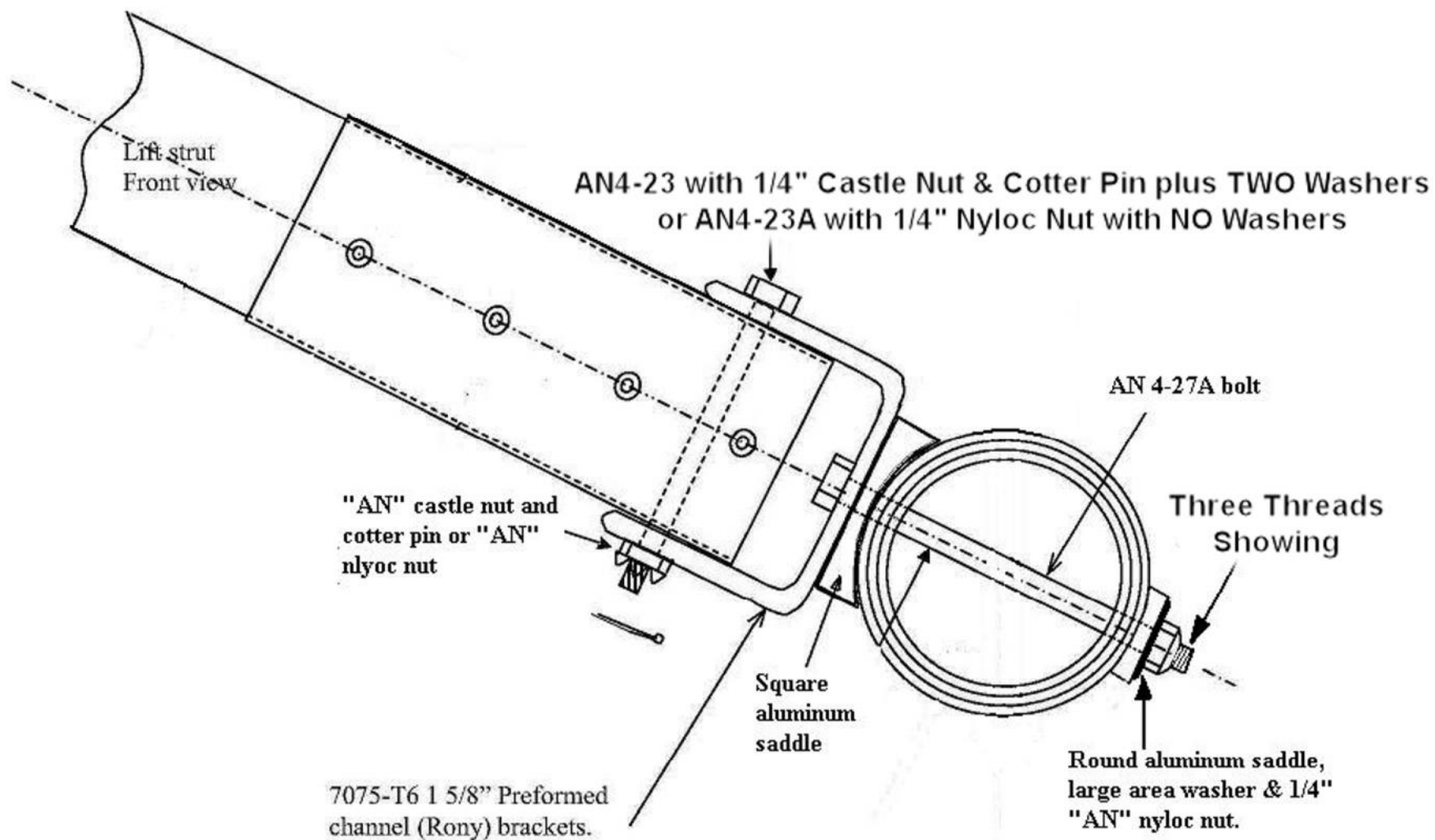

**ALL BOLTS MUST BE
INSTALLED EXACTLY AS SHOWN**

**DO NOT OVERTIGHTEN NUTS
ONLY TIGHTEN UNTIL JUST SNUG**

WITHOUT HEAVY LOAD SADDLES

How to attach lift struts to fuselage

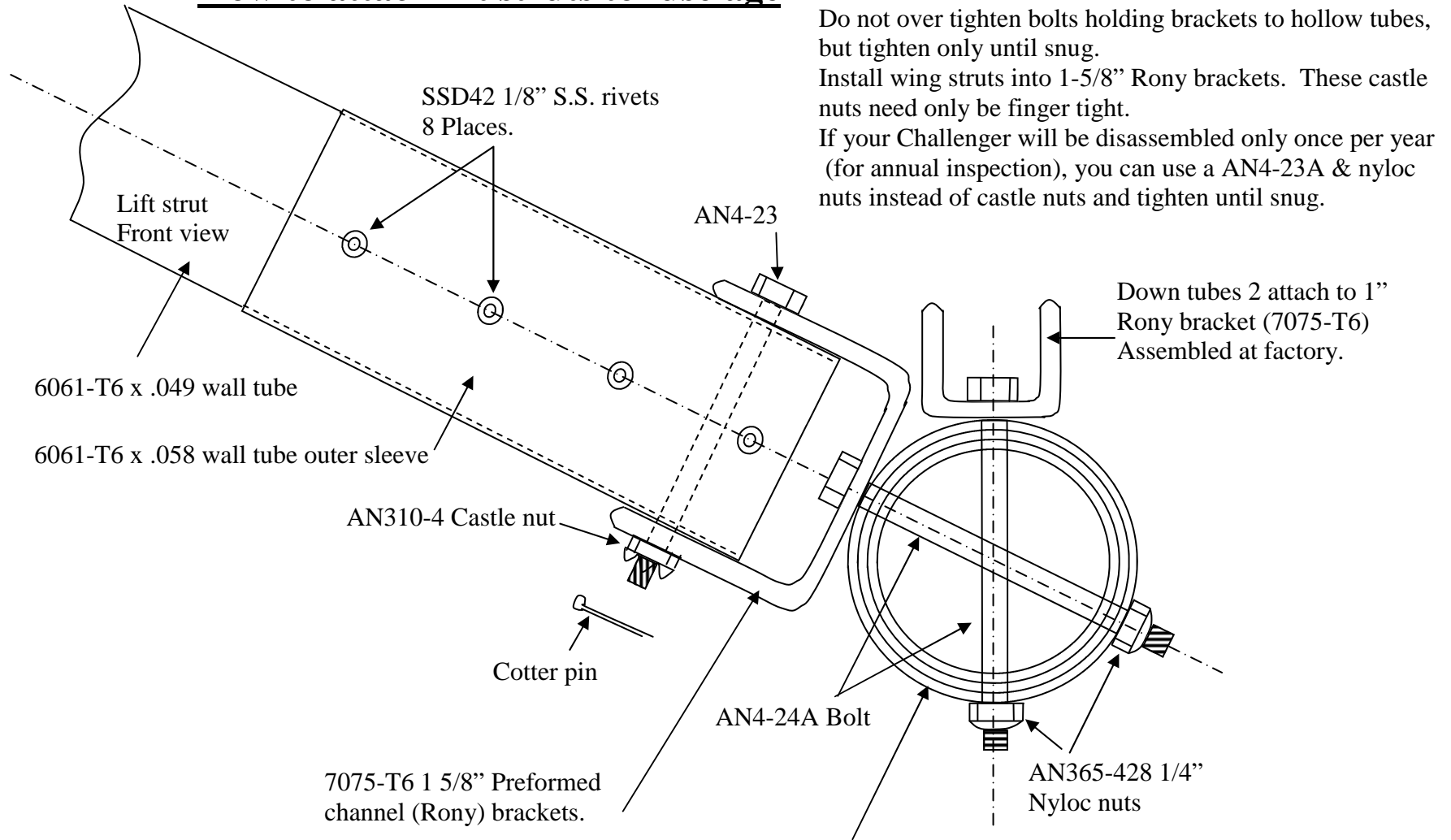

Do not over tighten bolts holding brackets to hollow tubes, but tighten only until snug.
Install wing struts into 1-5/8" Rony brackets. These castle nuts need only be finger tight.
If your Challenger will be disassembled only once per year (for annual inspection), you can use a AN4-23A & nyloc nuts instead of castle nuts and tighten until snug.

**ALL BOLTS MUST BE
INSTALLED EXACTLY AS SHOWN**

Triple wall, sleeved longeron section
(static tested to 2,000lb.) Total wall
Thickness = 3/16"

How to attach Wing Spars to the root tube.

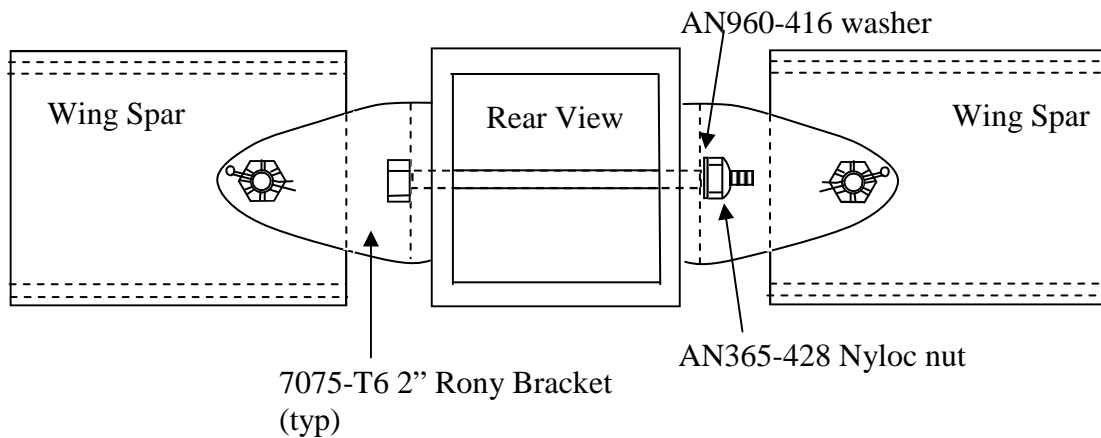
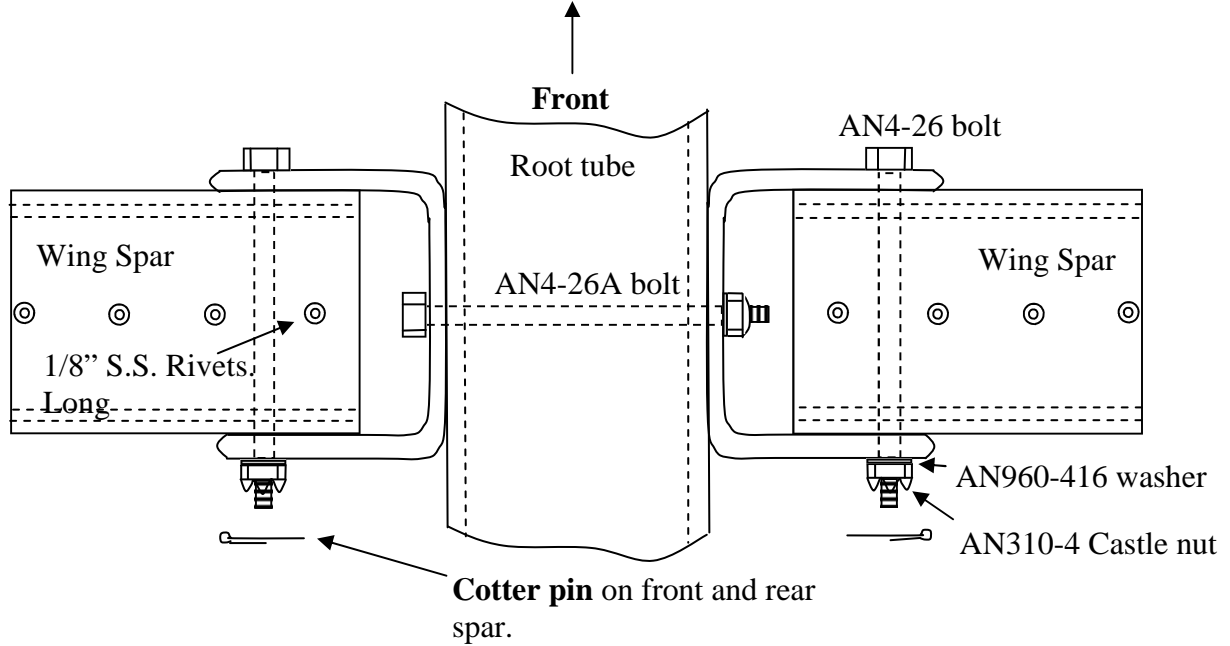

Install wing spar and strut attach brackets as per illustrations.

Do not over tighten bolts holding brackets to hollow tubes, but tighten only until snug.

Install wings into 2" Rony brackets (as shown above) and wing struts into 1-5/8" Rony brackets. These castle nuts need only be finger tight.

If your Challenger will be disassembled only once per year (for annual inspection), you can use an AN4-26A bolt & nyloc nuts instead of castle nuts and tighten until snug.